



Version	6
Total pages	20
Date	2005.12.16

FOR JUNGLIM INTERNAL USE ONLY

Product Specification

7" color TFT-LCD module

MODEL NAME: A070VW01 V1

- (◆) Preliminary Specification
- (.....) Final Specification

Note: The content of this specification is subject to change.

© 2005 AU Optronics
All Rights Reserved,
Do Not Copy.

Contents:

A. Physical specification	P3
B. Electrical specifications	P3
1. Pin assignment.....	P4
a. TFT-LCD panel driving section.....	P4
b. Backlight driving section.....	P5
2. Absolute maximum ratings.....	P5
3. Electrical characteristics.....	P6
a. Typical operating conditions.....	P6
b. Current consumption.....	P6
c. Backlight driving conditions.....	P6
4. AC Timing.....	P7
a. Timing conditions.....	P7
b. Power on/off sequence.....	P7
c. Timing diagram.....	P7
C. Optical specifications	P8
D. Reliability test items	P10
E. Packing form	P11

Appendix:

Fig.1 Outline dimension of TFT-LCD module (Front Side).....	P12
Fig.2 Outline dimension of TFT-LCD module (Rear Side)	P13
Fig.3 Operation Mode 1.....	P14
Fig.4 Operation Mode 2	P15
Fig.5 Horizontal timing.....	P16
Fig.6 Vertical shift timing	P17
Fig.7 Vertical timing (from up to down)	P18

FOR JUNGLIM INTERNAL USE ONLY

A. Physical specifications

NO.	Item	Specification	Remark
1	Display resolution(dot)	800RGB(W)×480(H)	
2	Active area(mm)	152.40W)×91.44(H)	
3	Screen size(inch)	7.0(Diagonal)	
4	Pixel pitch(mm)	0.1905(W)×0.1905(H)	
5	Color configuration	R. G. B. stripe	
6	Overall dimension(mm)	165(W)×104(H)×6(D)	Note 1
7	Weight(g)	190 ±10	
8	Surface treatment	AG(5.5%) with WV film	
9	Backlight unit	CCFL	

Note 1: Refer to Fig. 1

FOR JUNGLIM INTERNAL USE ONLY

B. Electrical specifications

1.Pin assignment

FH12-50S-0.5SH(Hirose) — FPC I/O Pin Assignment and Control Board I/O pin assignment

Pin no	Symbol	I/O	Description	Remark
1	GND	P	Ground for gate drive	
2	VCC	P	Digital voltage for gate driver	
3	VGL	P	TFT low voltage	
4	VGH	P	TFT high voltage	
5	STVL	I/O	Start pulse signal input/output (Vertical)	
6	STVR	I/O	Start pulse signal input/output (Vertical)	
7	CKV	I	CLK (Vertical)	
8	U/D	I	Up or Down display control	
9	OEV	I	Output enable	
10	VCOM	I	VCOM voltage	
11	DIO1	I/O	Start pulse signal input/output (Horizontal)	
12	AVDD	P	Analog voltage for source driver	
13	AVSS	P	Analog ground for source driver	
14	GND	P	Digital ground for source driver	
15	VCC (DVDD)	P	Digital voltage for source driver	
16	EDGSL	I	Select raising edge or raising/falling edge	
17	CLK	I	Sample CLK	
18	SHL(R/L)	I	Right or Left display control	
19	R0	I	Red data	
20	R1	I	Red data	
21	R2	I	Red data	
22	R3	I	Red data	
23	R4	I	Red data	
24	R5	I	Red data	
25	G0	I	Green Data	
26	G1	I	Green Data	
27	G2	I	Green Data	
28	G3	I	Green Data	
29	G4	I	Green Data	
30	G5	I	Green Data	
31	V1	I	Reference voltage	
32	V2	I	Reference voltage	
33	V3	I	Reference voltage	
34	V4	I	Reference voltage	
35	V5	I	Reference voltage	
36	V6	I	Reference voltage	
37	V7	I	Reference voltage	
38	V8	I	Reference voltage	
39	V9	I	Reference voltage	
40	V10	I	Reference voltage	
41	B0	I	Blue Data	

42	B1	I	Blue Data	
43	B2	I	Blue Data	
44	B3	I	Blue Data	
45	B4	I	Blue Data	
46	B5	I	Blue Data	
47	LD (OEH)	I	Latch and switch data to output	
48	REV	I	Control data are inverted or not	
49	POL	I	Polarity selection	
50	DIO2	I/O	Start pulse signal input/output (Horizontal)	

FOR JUNGLIM INTERNAL USE ONLY

2. Absolute Maximum Ratings

Items	Symbol	Product Specification			Unit
		Min.	Typ.	Max.	
Power Voltage	Vcc	-0.3		5	V
	AVDD	-0.5		12	V
	VGH	-0.3		18	V
	VGL	-15		0.3	V
	VGH-VGL			33	V
Input Signal Voltage	Vi	-0.3		Vcc+0.3	V
	Vref(V1~V5)	0.4AVDD		AVDD+0.3	V
	Vref(V6~V10)	-0.3		0.6AVDD	V
	Vcom	3.5		3.9	V
Operating Temperature	Topa	-30		85	°C
Storage Temperature	Tstg	-40		95	°C

3. Electrical characteristics

a. Typical operating conditions (GND=AVSS=0V)

Items	Symbol	Product Specification			Unit
		Min.	Typ.	Max.	
Power Voltage	V _{CC}	3.0	3.3	3.6	V
	AVDD	8.4	8.8	9.2	V
	V _{GH}	14.0	15.0	16.0	V
	V _{COM}	3.5	3.7	3.9	V
	V _{GL}	-6.5	-7	-7.5	V
Input Reference Voltage	V _{1~V5}	0.4AVDD	—	AVDD-0.1	V
	V _{6~V10}	0.2	—	0.6AVDD	V
Input H/L level Voltage	V _{IH}	0.8V _{CC}	—	V _{CC}	V
	V _{IL}	0	—	0.2V _{CC}	V

a. Current consumption conditions (GND=Avss=0V)

Parameter	Symbol	Condition	Min.	Typ.	Max.	Unit
Current For Driver	I _{GH}	V _{GH} =15V		150	300	uA
	I _{GL}	V _{GL} =-7V		-150	-300	uA
	I _{CC}	V _{CC} =3.3V		3.5	5	mA
	I _{DD}	AVDD=8.8V		20	30	mA

b. Backlight driving conditions

Parameter	Symbol	Min.	Typ.	Max.	Unit	Remark
Lamp voltage	V _L	-	580	640	V _{rms}	
Lamp current	I _L	-	6	7	mArms	
Frequency	F _L	-	60	80	kHz	Note 3
Lamp starting voltage	V _S	-	-	1070	V _{rms}	Note 1,4
		-	-	1,290	V _{rms}	Note 2,4
Lamp life time		10,000	-	-	Hr	Note 5

Note 1: Ta = 25°C.

Note 2: Ta = 0°C.

Note 3: The lamp frequency should be selected as different as possible from display horizontal synchronous signal to avoid interference.

Note 4: For starting the backlight unit, the output voltage of DC/AC's transformer should be larger than the maximum lamp starting voltage.

Note 5: The "Lamp life time" is defined as the module brightness decrease to 50% original brightness at Ta=25°C, I_L=6mA.

4. AC Timing

a. Timing conditions

AC Electrical Characteristics (VCC=3.3V, AVDD=8.8.V, AVSS=GND=0V, TA=25°C)

Parameter	Symbol	Min.	Typ.	Max.	Unit
CLK frequency	Fclk		40	42	MHz
CLK pulse width	Tcw	8			ns
Data set-up time	Tsu	4			ns
Data hold time	Thd	2			ns
Propagation delay of DIO2/1	Tphl	6	10	15	ns
Time that the last data to LD	Tld	1			Tcw
Pulse width of LD	Twld	2			Tcw
Time that LD to DIO1/2	Tlds	5			Tcw
POL set-up time	Tpsu	6			ns
POL hold time	Tphd	6			ns
OEV pulse width	TOEV		12		Tcw
CKV pulse width	TCKV	16	28	40	Tcw
Horizontal display start	TSH		0		Tcw/3
Horizontal display timing range	TDH		800		Tcw/3
STV setup time	TSUV	400			ns
STV hold time	THDV	400			ns
STV pulse width	TSTV			1	TDH
Horizontal lines per field	TV	512	525	610	TDH
Vertical display start	TSV		3		TDH
Vertical display timing range	TDV		480		TDH

DC Electrical Characteristics

Parameter	Symbol	Min.	Typ.	Max.	Unit
Supply Voltage	Vcc	3.0	3.3	3.6	V
Low Level Input Voltage	Vil	0	-	0.2*Vcc	V
High Level Input Voltage	Vih	0.8*Vcc	-	Vcc	V
High Level Output Voltage	Voh	Vcc-0.4	-	-	V
Low Level Output Voltage	Vol	GND	-	GND+0.4	V
Supply Voltage	AVDD	8.4	8.8	9.2	V
Sinking Current of Outputs	IOL	-80	-	-	uA
Driving Current of Outputs	IOH	80	-	-	uA

b. Power on/off sequence

Panel Gate IC is a high-voltage LCD driver, so it may be damaged by a large current flow if an incorrect power sequence is used. Connecting the drive powers, VGL & VGH, after the logical power, VCC, is the recommended sequence. When shutting off the power, shut off the drive power and then the logic system or turn off all powers simultaneously.

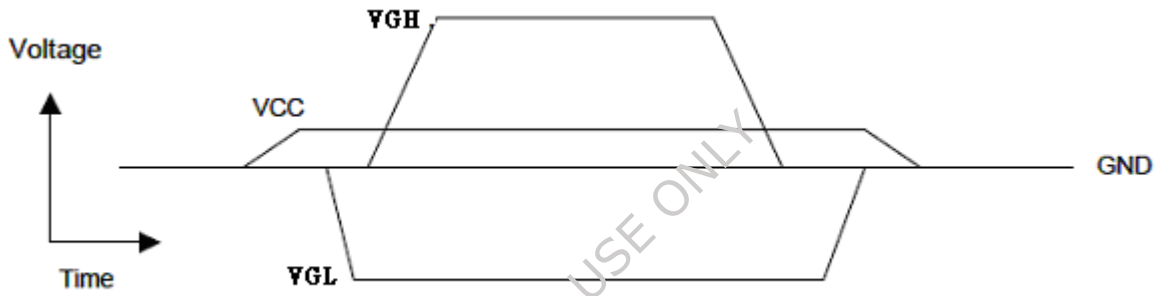

Fig. Power on/off sequence

c. Timing diagram : Appendix on page 14

C. Optical specification (Note 1, Note 2)

Item		Symbol	Condition	Min.	Typ.	Max.	Unit	Remark
Response time	Rise	Tr	$\theta = 0^\circ$	-	12	50	ms	Note 3,5
	Fall	Tf		-	18	60	ms	
Contrast ratio		CR	At optimized Viewing angle	200	300	-		Note 4, 5
Viewing angle	Top		$CR \geq 10$	30	40	-	deg.	Note 5, 6
	Bottom			50	60	-		
	Left			50	60	-		
	Right			50	60	-		
Viewing angle	Top		$CR \geq 5$	40	50	-	deg.	Note 5, 6
	Bottom			60	70	-		
	Left			60	70	-		
	Right			60	70	-		
Brightness		Y_L	$I_L = 6mA, 25^\circ C$	300	400	-	nit	Note 7
White chromaticity		X	$\theta = 0^\circ$	0.26	0.31	0.36		Note 7
		Y	$\theta = 0^\circ$	0.29	0.34	0.39		

Note 1 : Ambient temperature =25°C , and lamp current $I_L = 6$ mArms. To be measured in the dark room.

Note 2 :To be measured on the center area of panel with a viewing cone of 1°by Topcon luminance meter BM-5A, after 10 minutes operation.

Note 3. Definition of response time:

The output signals of photo detector are measured when the input signals are changed from "black" to "white"(falling time) and from "white" to "black"(rising time), respectively. The response time is defined as the time interval between the 10% and 90% of amplitudes. Refer to figure as below.

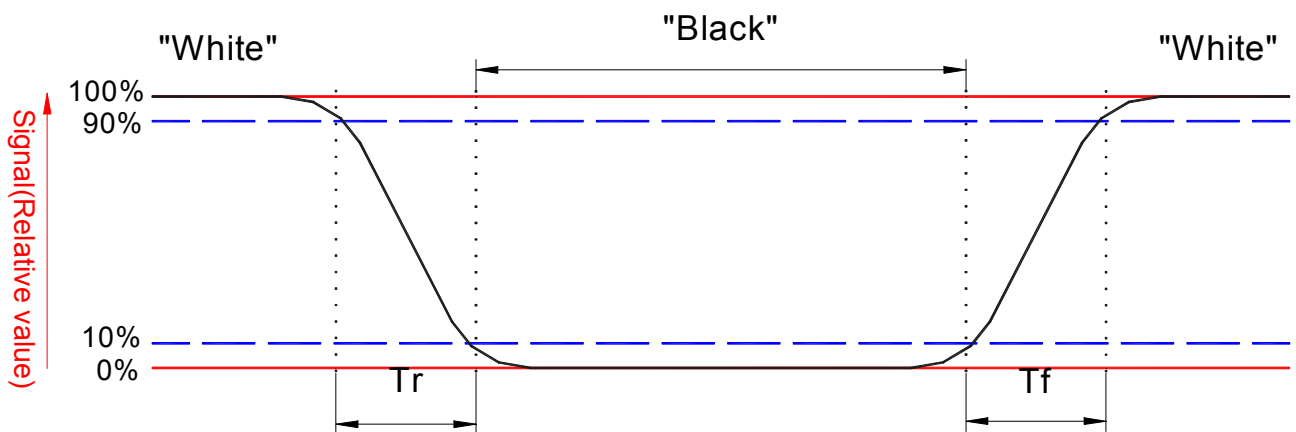

Note 4. Definition of contrast ratio:

Contrast ratio is calculated with the following formula.

$$\text{Contrast ratio (CR)} = \frac{\text{Photo detector output when LCD is at "White" state}}{\text{Photo detector output when LCD is at "Black" state}}$$

Note 5. White $V_i = V_{i50} + 1.5V$

Black $V_i = V_{i50} \pm 2.0V$

“±” means that the analog input signal swings in phase with V_{COM} signal.

“+” means that the analog input signal swings out of phase with V_{COM} signal.

V_{i50} : The analog input voltage when transmission is 50%

The 100% transmission is defined as the transmission of LCD panel when all the input terminals of module are electrically opened.

Note 6. Definition of viewing angle, Refer to figure as below.

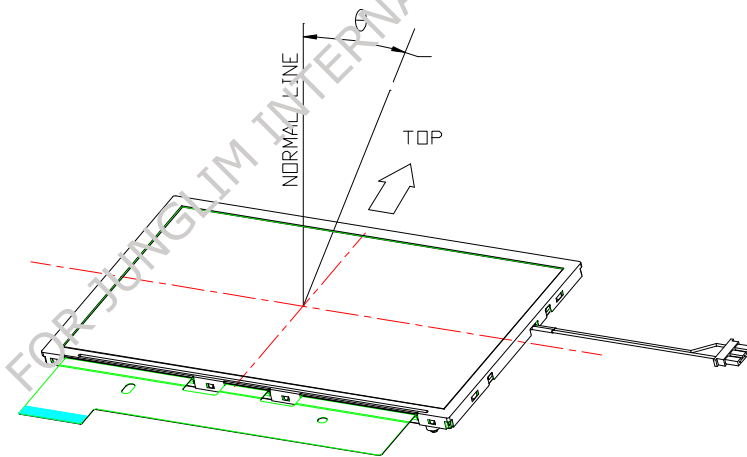

Note 7. Measured at the center area of the panel when all the input terminals of LCD panel are electrically opened.

D. Reliability test items(Note 2):

No.	Test items	Conditions	Remark
1	High temperature storage	Ta= 65°C 240Hrs	
2	Low temperature storage	Ta= -20°C 240Hrs	
3	High temperature operation	Tp= 60°C 240Hrs	
4	Low temperature operation	Ta= 0°C 240Hrs	
5	High temperature and high humidity	Tp= 50°C, 80% RH 240Hrs	Operation
6	Heat shock	-20°C~60°C/100 cycles 1Hrs/cycle	Non-operation
7	Electrostatic discharge	±200V,200pF(0Ω), once for each terminal	Non-operation
8	Vibration	Frequency range : 8~33.3Hz Stoke : 1.3mm Sweep : 2.9G, 33.3 ~ 400Hz Cycle : 15 minutes 2 hours for each direction of X,Z 4 hours for Y direction	JIS C7021, A-10 condition A
9	Mechanical shock	100G, 6ms, ±X,±Y,±Z 3 times for each direction	JIS C7021, A-7 condition C
10	Vibration (with carton)	Random vibration: 0.015G ² /Hz from 5~200Hz -6dB/octave from 200~500Hz	IEC 68-34
11	Drop (with carton)	Height: 60cm 1 corner, 3 edges, 6 surfaces	JIS Z0202

Note1: Ta: Ambient Temperature.

Note2: Tp: Panel Surface Temperature

Note3: In the standard conditions, there is not display function NG issue occurred. All the cosmetic specification is judged before the reliability stress.

E. Packing form

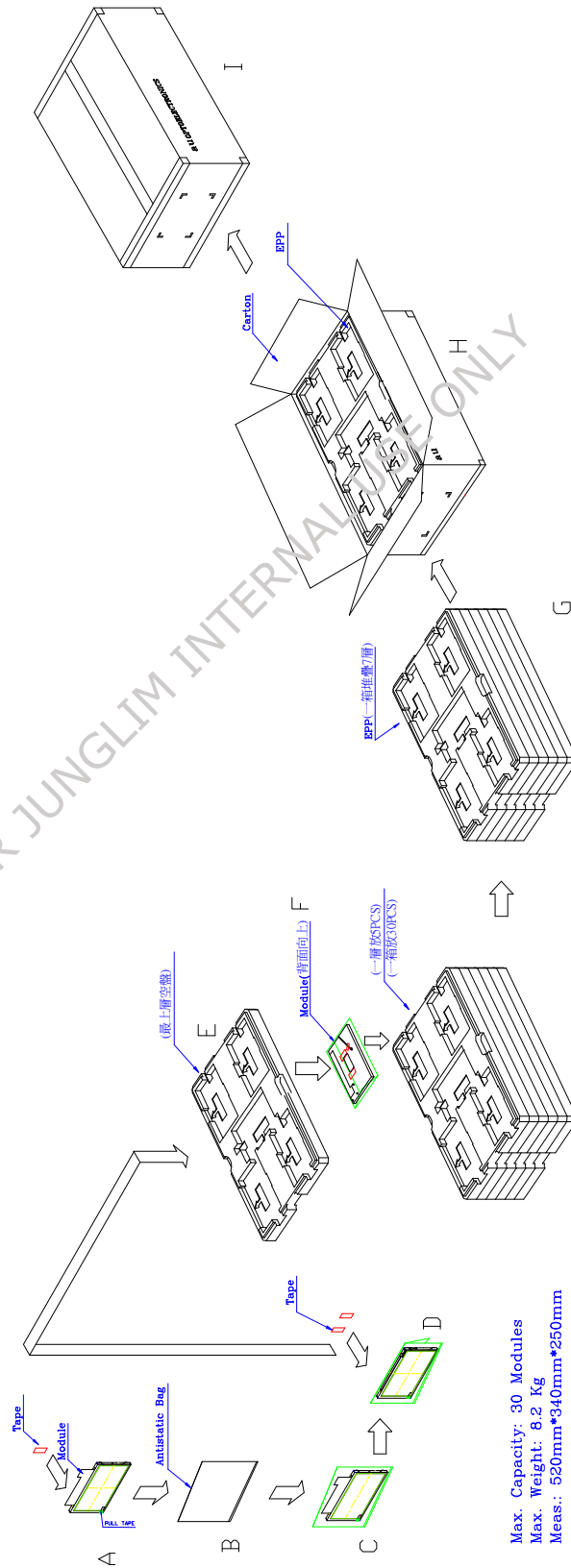

Max. Capacity: 30 Modules
 Max. Weight: 8.2 Kg
 Meas.: 520mm*340mm*250mm

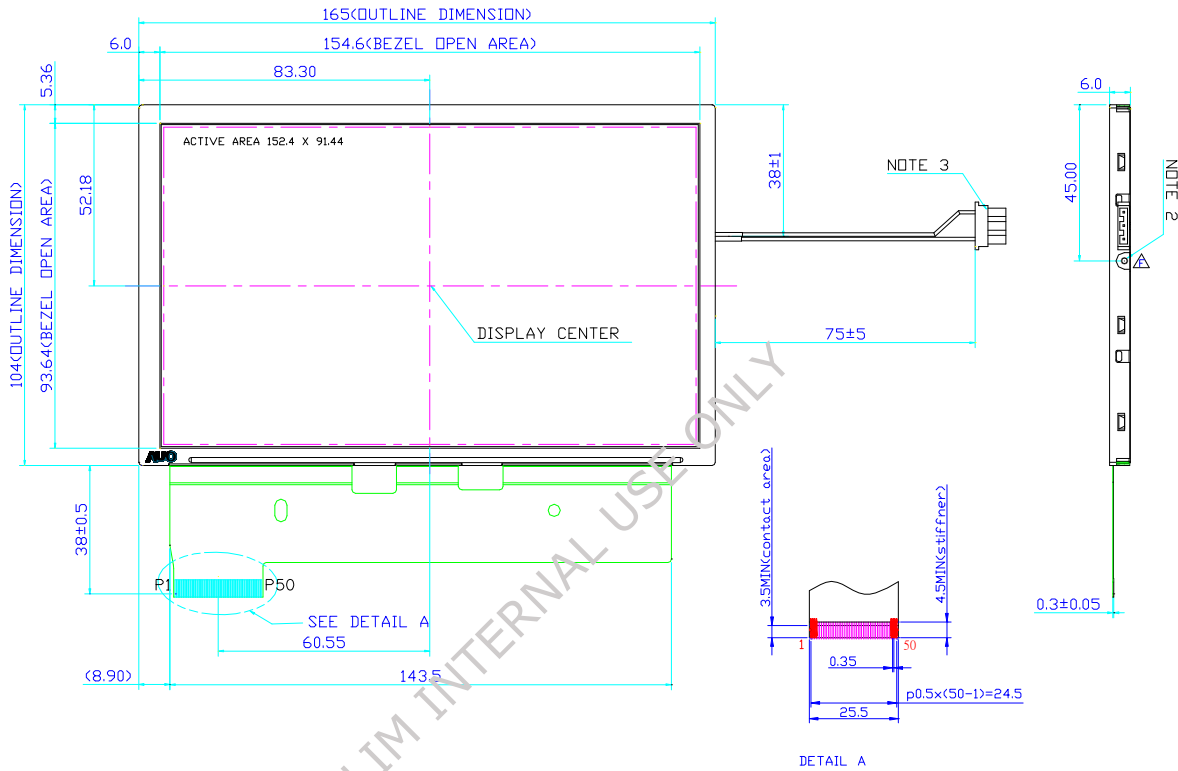

NOTES:

- 1.General Tolerance : ±0.3
- 2.Ground wire Fixed,Using M2.0XP0.4XL1.5mm Screw (Customer side)
- 3.Lamp connector : JST/BHR-03VS-1
- 4.TWO SIDE TAPE 80X6 mm

Fig.1 Outline dimension of TFT-LCD module(Front side)

■ Timing Diagram 1 (CHNSL="1" , Default)

<< EDGSL="0", Default >>

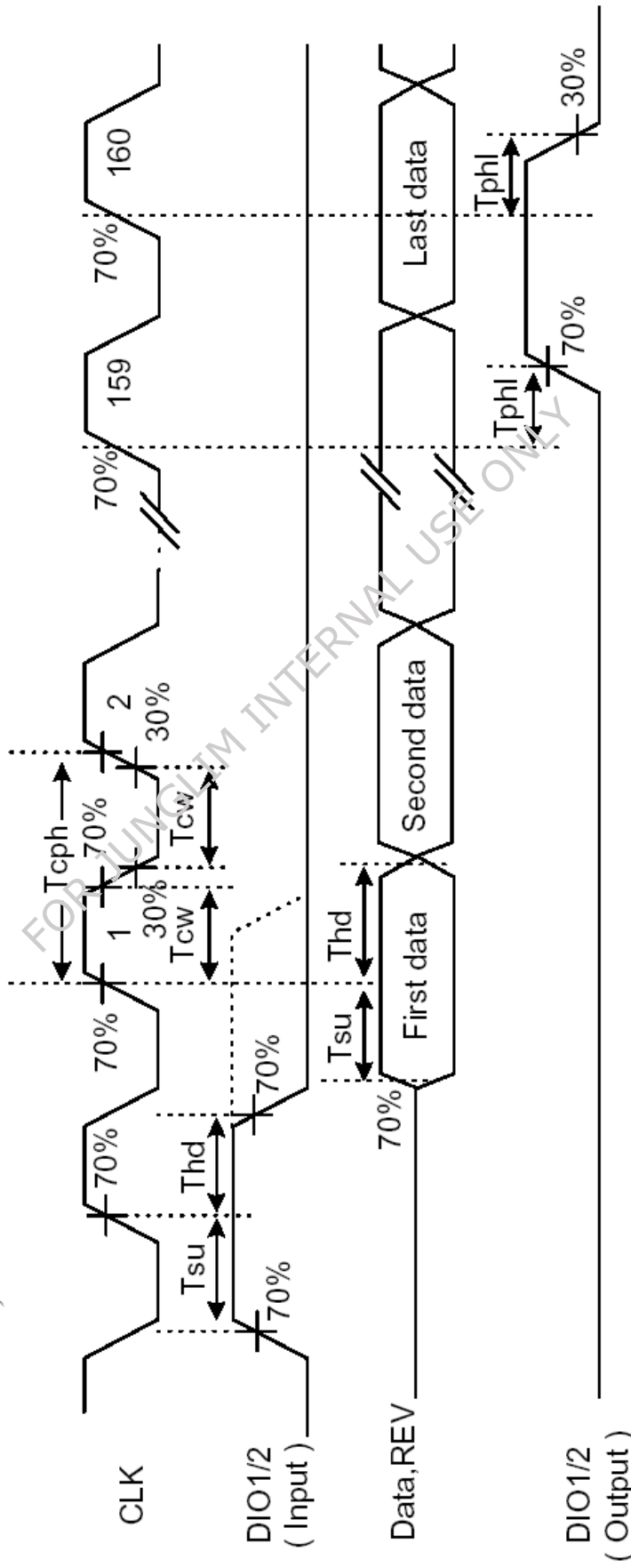

Fig.3 Operation Mode 1

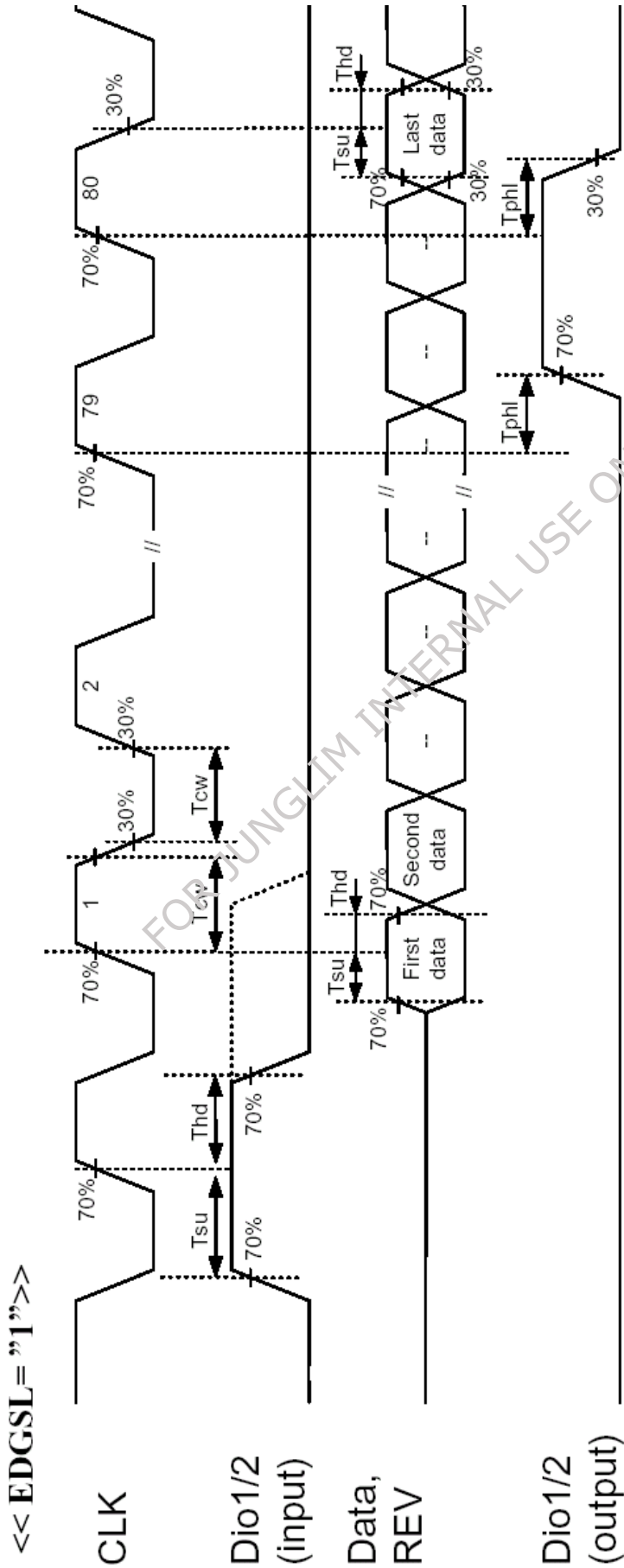

Fig.4 Operation Mode 2

■ Timing Diagram 2

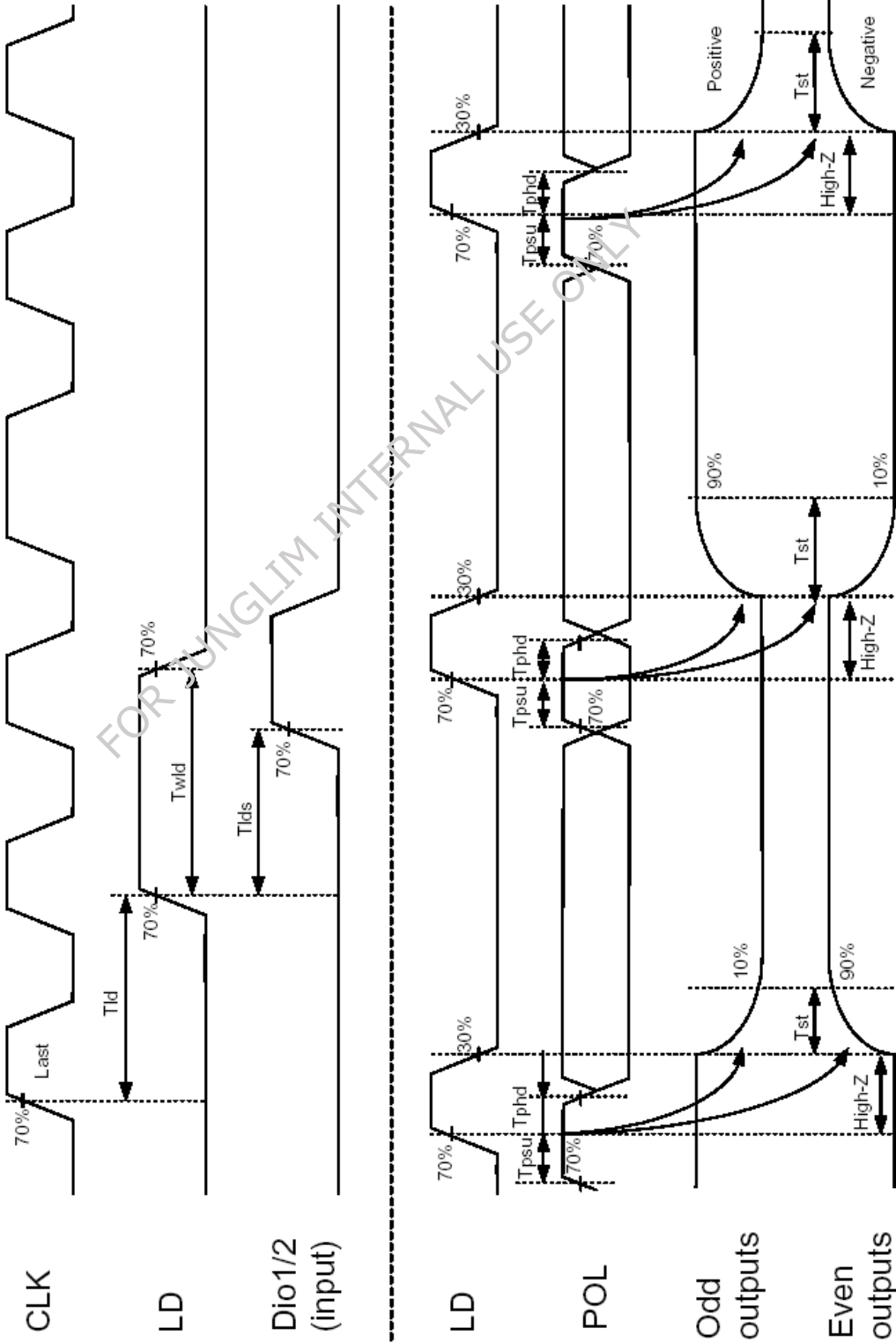

Fig.5 Horizontal timing

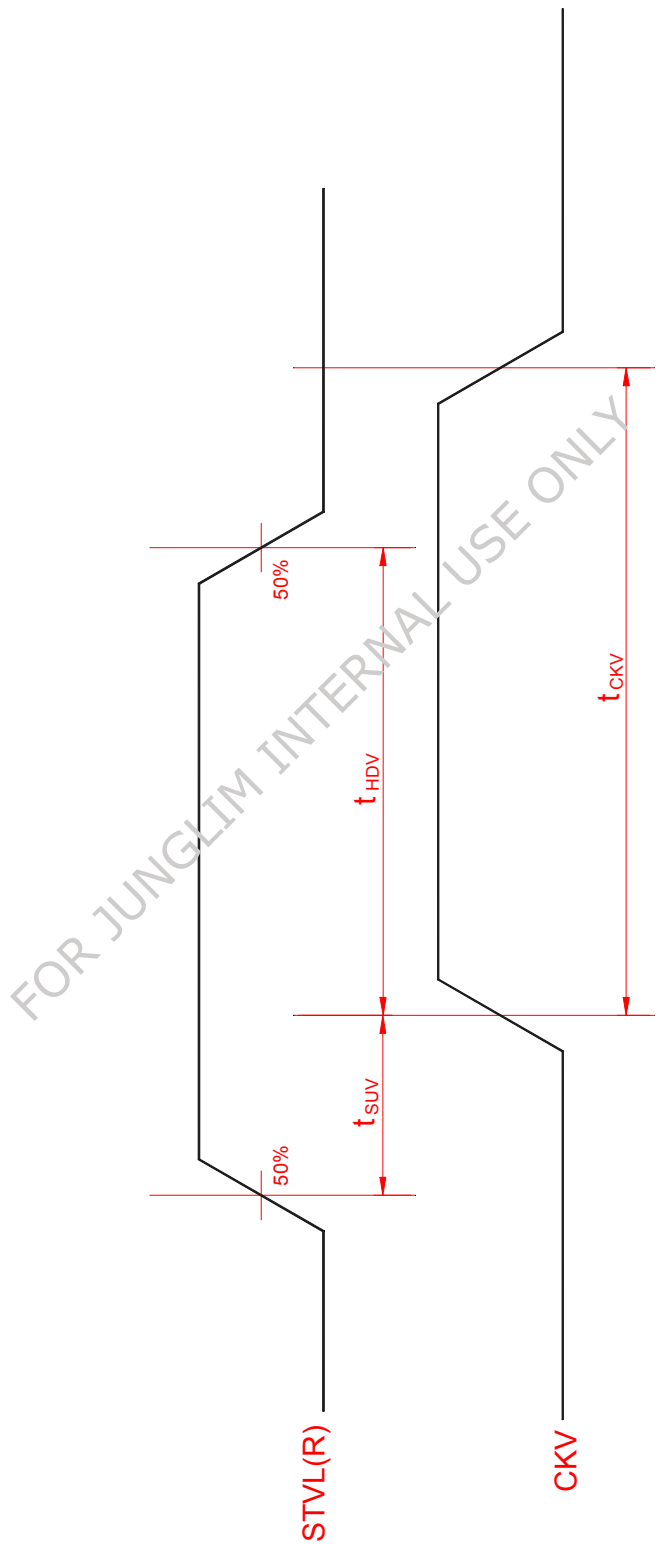

Fig.6 Virtual shift clock timing

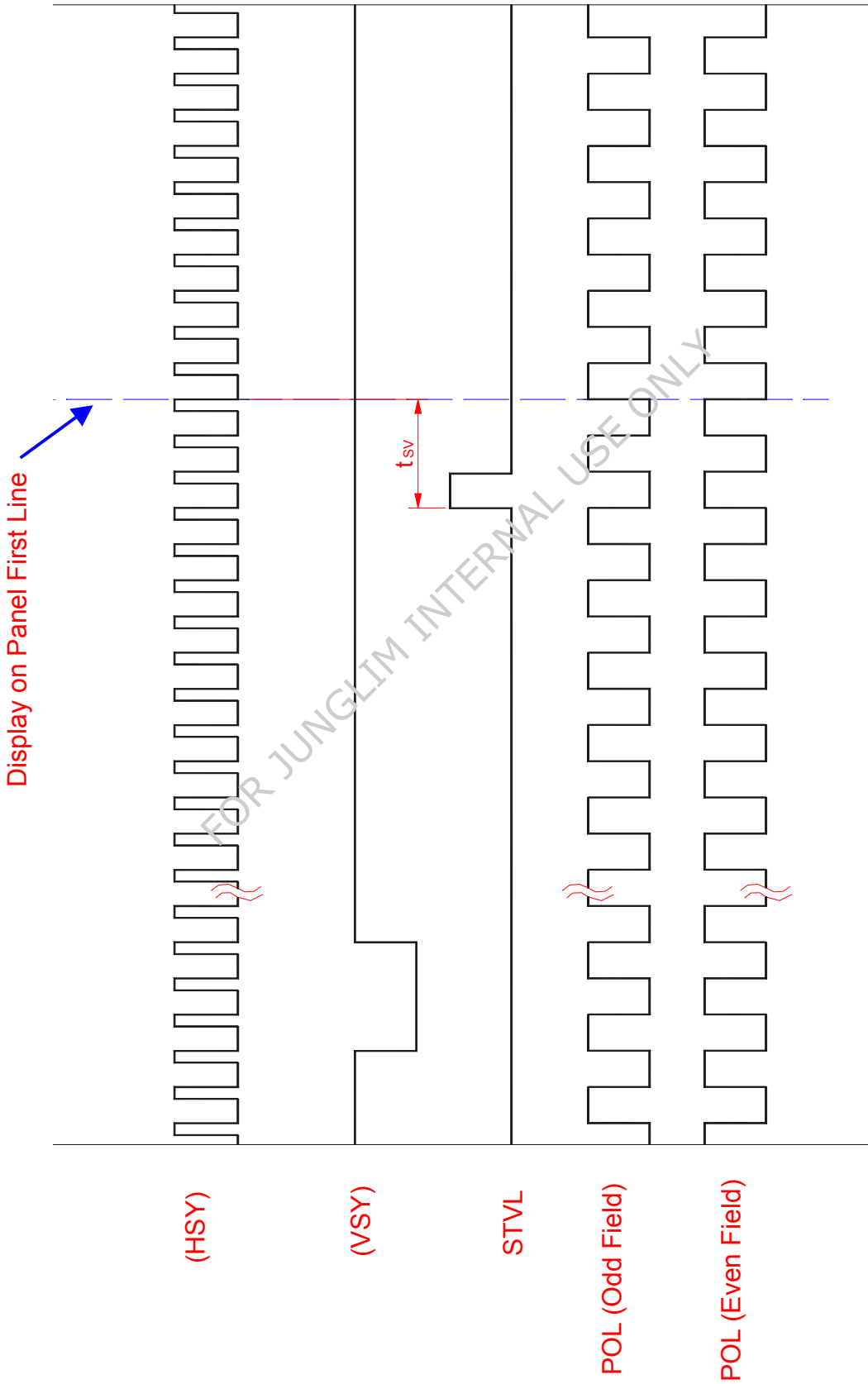

Fig.7 Vertical timing (from up to down)