

Doc. Version	0.1
Total Pages	15
Date	2006/06/06

**Product Specification**  
**7.0" COLOR TFT-LCD MODULE**

**MODEL NAME: A070VW02 V1**

<◆>Preliminary Specification  
< >Final Specification

© 2006 AU Optronics  
All Rights Reserved.

**DO NOT COPY**

Note: The content of this specification is subject to change.

Record of Revision

Version	Revise Date	Page	Content
0.0	12/Apr/2006		First draft.
0.1	6/Jun/2006	4	Revise Weight
		8	Revise Absolute Maximum Rating
		9	Revise TFT- LCD Typical Operation Condition
		12	Revise White Chromaticity
		13	Revise the drawing of definition of viewing angle

## Contents

<b>GENERAL DESCRIPTION</b>	<b>3</b>
<b>FEATURES</b>	<b>3</b>
<b>1. GENERAL INFORMATION</b>	<b>4</b>
<b>2. ELECTRICAL SPECIFICATIONS</b>	<b>7</b>
2.1 FPC PIN ASSIGNMENT	7
2.2 ABSOLUTE MAXIMUM RATINGS	8
<b>3. ELECTRICAL CHARACTERISTICS</b>	<b>9</b>
3.1 TFT- LCD TYPICAL OPERATION CONDITION (GND=AVSS=0V)	9
3.2 BACKLIGHT DRIVING CONDITIONS	9
3.3 AC TIMING	10
3.3.1 INPUT TIMING DIAGRAM	10
3.3.2 TIMING CONDITION	10
<b>4. OPTICAL SPECIFICATION</b>	<b>12</b>
<b>5. ABSOLUTE RATINGS OF AMBIENT ENVIRONMENT</b>	<b>14</b>
<b>6. PACKING FORM</b>	<b>15</b>

## General Description

A070VW02 V1 is a amorphous transmissive type TFT (Thin Film Transistor) LCD (Liquid crystal Display). This model is composed of TFT-LCD, drive IC, backlight unit, and driving board.

## Features

- 7-inch display size
- WVGA resolution and stripe dot arrangement
- Built in timing controller and one DC-DC controller
- Single 3.3V power supply for LCD. 6.6V/200mA for LED backlight
- Up/Down, Left/Right reversion selection
- SYNC + DE Mode
- Low power consumption
- TTL 6bits interface support:
- Wide viewing angle
- Green design

FOR PROMATE INTERNAL USE ONLY

## 1. General Information

NO.	Item	Unit	Specification	Remark
1	Display Resolution	dot	800RGB(H)×480(V)	
2	Active Area	mm	152.40(H)×91.44(V)	
3	Screen Size	inch	7.0(Diagonal)	
4	Pixel Pitch	mm	0.1905(H)×0.1905(V)	
5	Color Configuration	--	R. G. B. Stripe	Note 1
6	Color Depth	--	262K Colors	Note 2
7	Overall Dimension	mm	165(H) × 106(V) × 5.5(T)	Note 3
8	Weight	g	130 +/- 10%	
9	Panel surface treatment	--	Anti-Glare	
10	Display Mode	--	Normally White	

Note 1: Below figure shows dot stripe arrangement.

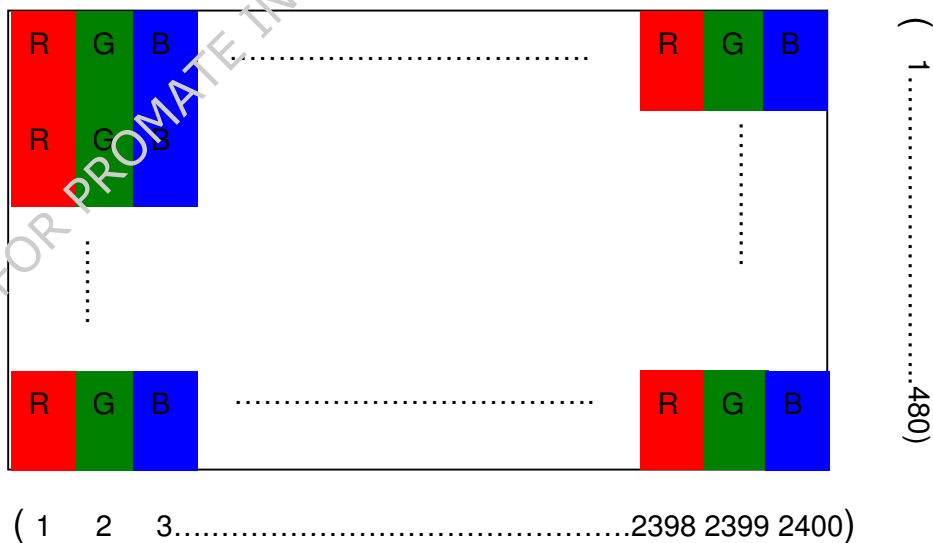

Note 2: The 262K color display depends on 6-bit data signal (pin 13~35).

Note 3: Not include backlight cable and screw height. Refer next page to get further information.

Outline Dimension of TFT-LCD Module – Front View

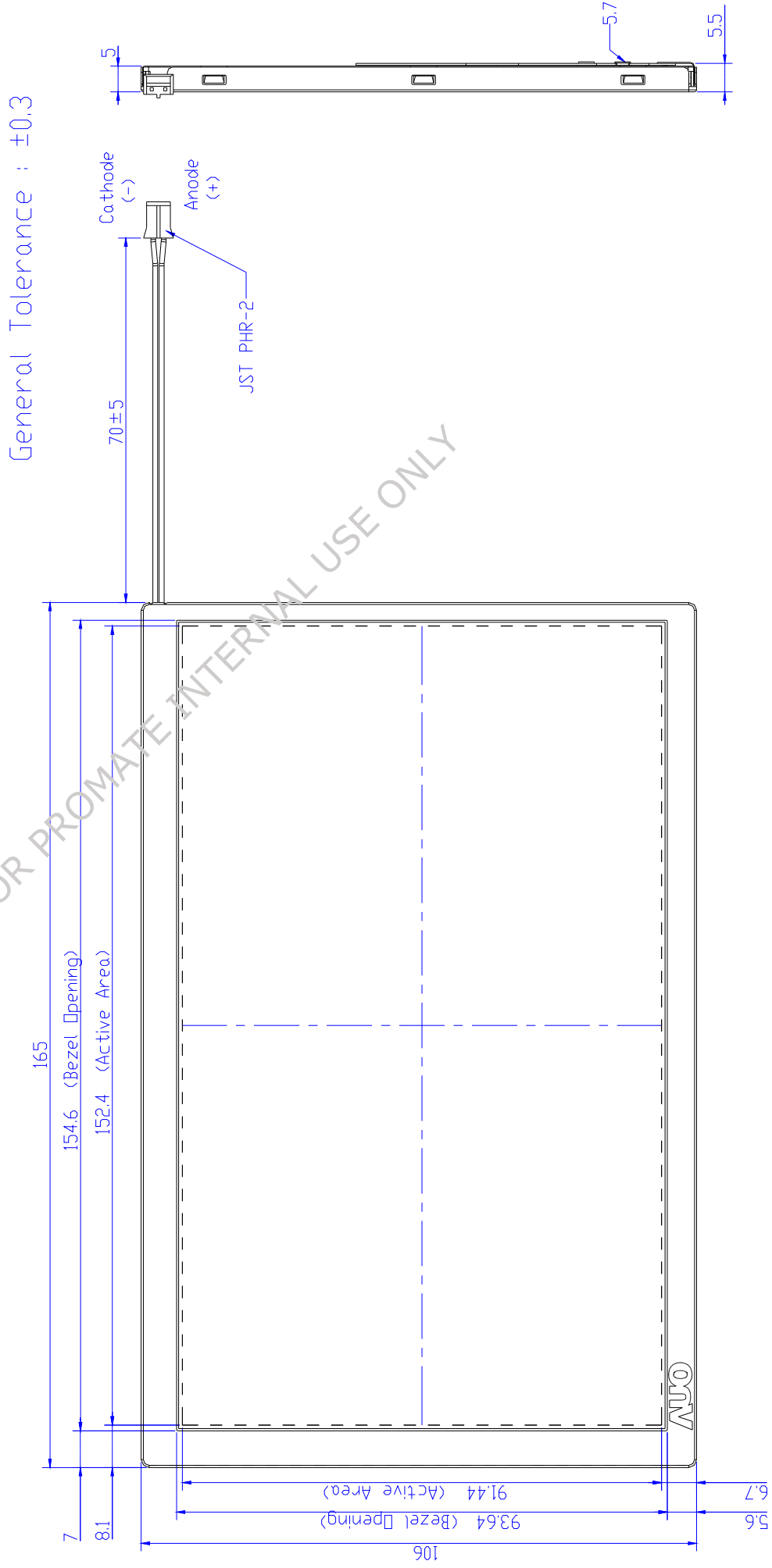

Outline Dimension of TFT-LCD Module –Back View

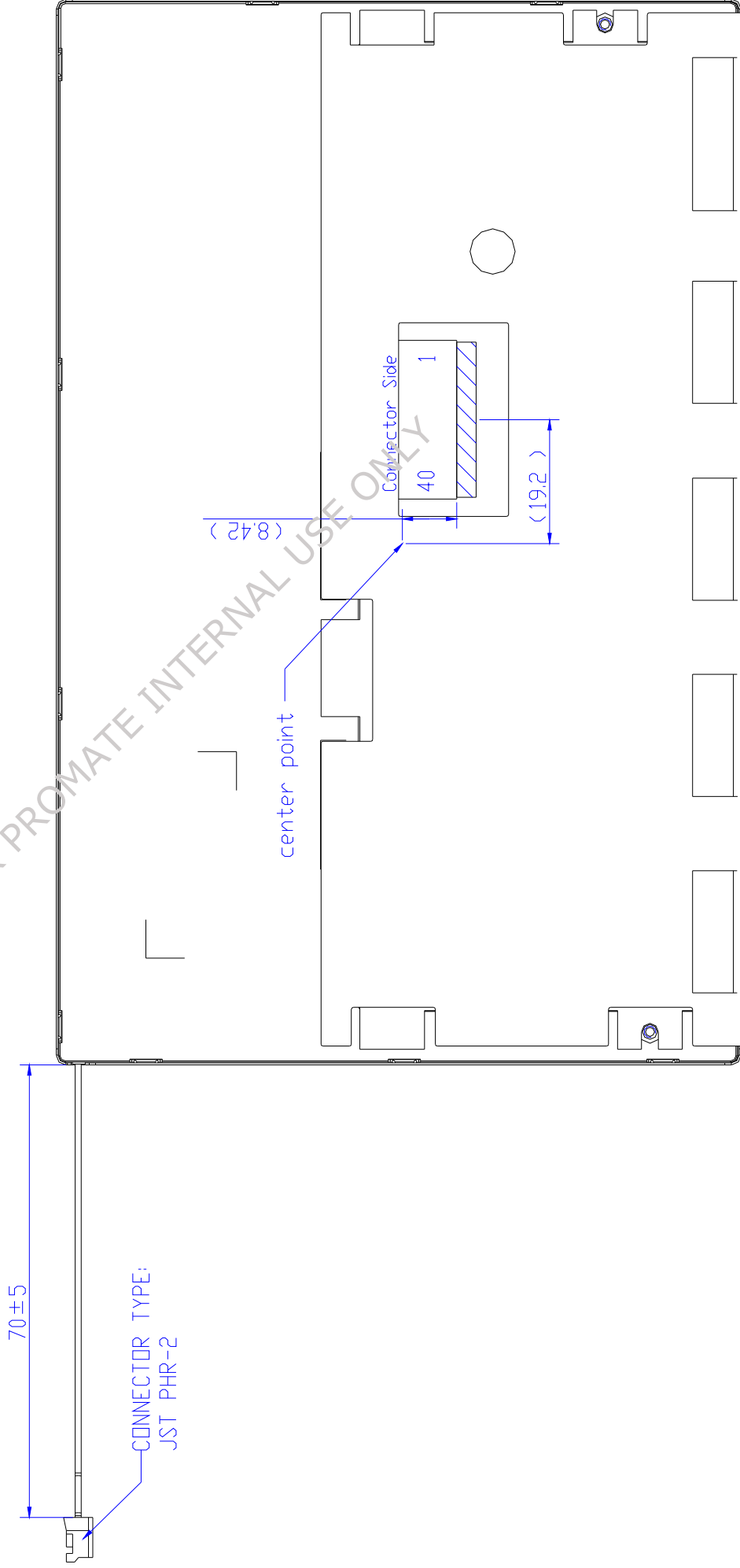

## 2. Electrical Specifications

### 2.1 FPC Pin Assignment

Pin NO	Symbol	I/O	Function
1	U/D	I	Up or down display control
2	VSS	G	GND
3	Hsync	I	Horizontal SYNC.
4	VDD	P	3.3V Power supply
5	VDD	P	3.3V Power supply
6	VDD	P	3.3V Power supply
7	VDD	P	3.3V Power supply
8	Vsync	I	Vertical SYNC.
9	DE	I	Data Enable
10	VSS	G	GND
11	VSS	G	GND
12	VSS	G	GND
13	B5	I	Blue data
14	B4	I	Blue data
15	B3	I	Blue data
16	VSS	G	GND
17	B2	I	Blue data
18	B1	I	Blue data
19	B0	I	Blue data
20	VSS	G	GND
21	G5	I	Green data
22	G4	I	Green data
23	G3	I	Green data
24	VSS	G	GND
25	G2	I	Green data
26	G1	I	Green data
27	G0	I	Green data
28	VSS	G	GND
29	R5	I	Red data
30	R4	I	Red data
31	R3	I	Red data
32	VSS	G	GND
33	R2	I	Red data
34	R1	I	Red data

Pin NO	Symbol	I/O	Function
35	R0	I	Red data
36	VSS	G	GND
37	VSS	G	GND
38	DCLK	I	Data Clock
39	VSS	G	GND
40	L/R	I	Right or left display control

I: Input pin; P: Power pin; G: Ground pin

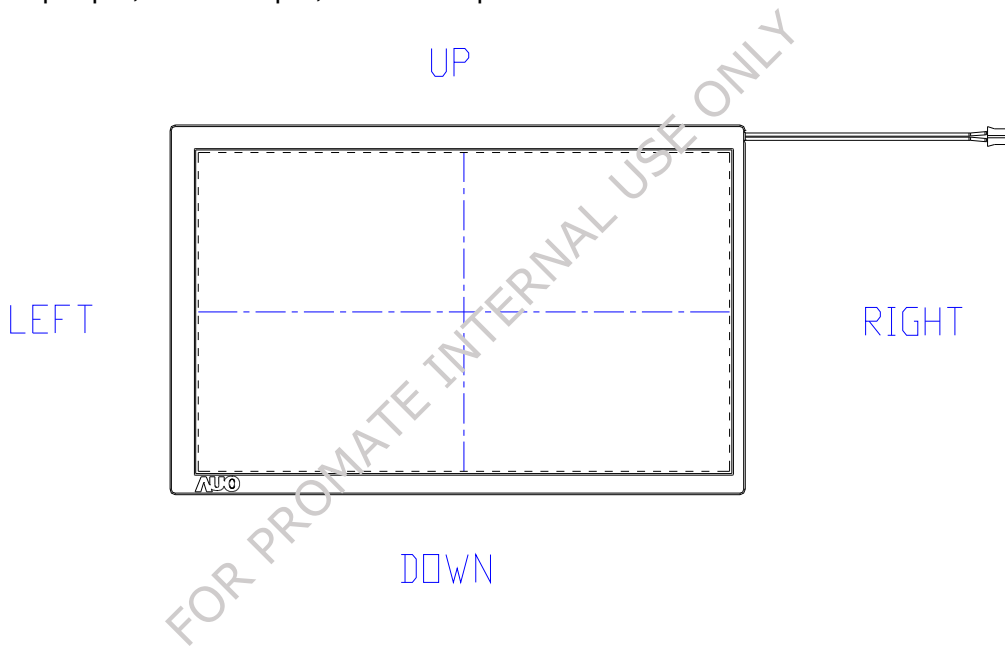

## 2.2 Absolute Maximum Ratings

Items	Symbol	Product Specification			Unit
		Min.	Typ.	Max.	
Power Voltage	VDD	-0.5		3.6	V
Input Signal Voltage	$V_i$	-0.3		VDD+0.3	V
Operation Temperature	Topa	0		60	□
Storage Temperature	Tstg	-20		65	□

### 3. Electrical Characteristics

The following items are measured under stable condition and suggested application circuit.

#### 3.1 TFT- LCD Typical Operation Condition (GND=AVSS=0V)

Items	Symbol	Product Specification			Unit
		Min.	Typ.	Max.	
Power Voltage	VDD	3.0	3.3	3.5	V
Power Current	IDD	--	0.15	0.2	A
Input Signal Voltage	Vi	-0.3	--	VDD+0.3	V
Input Signal H/L Level Voltage	VIH	0.8VDD	--	VDD	V
	VIL	0	--	0.2VDD	

Note: Above every operation range is based on stable operation

#### 3.2 Backlight Driving Conditions

Parameter	Symbol	Min.	Typ.	Max.	Unit
Voltage for LED	VLED	--	6.6	--	V
Current for LED	ILED	--	200	240	mA

### 3.3 AC Timing

#### 3.3.1 Input Timing Diagram

##### Input Timing (WVGA)

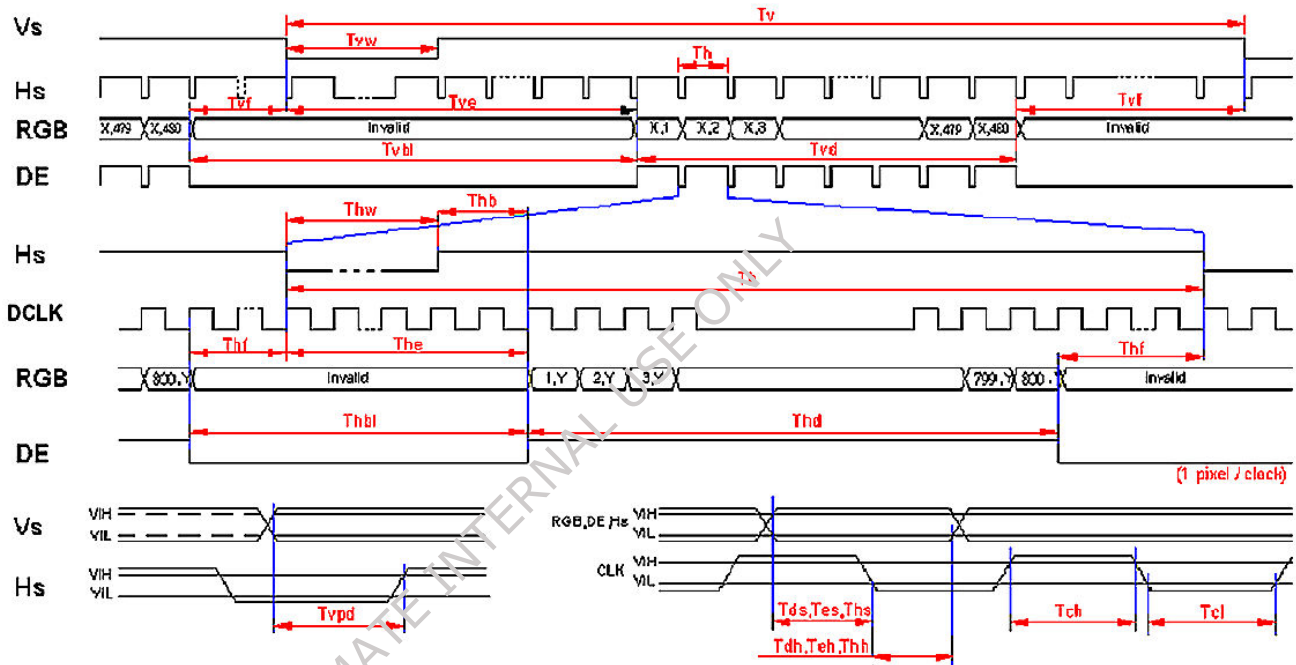

#### 3.3.2 Timing condition

##### 3.3.2.1. DE Mode

Item	Symbol	Min	Typ	Max	Unit	Remark
Clock frequency	Fck	20	33.3	42	MHz	
Clock High time	Twcl	8	—	—	ns	VIL
Clock Low time	Twch	8	—	—	ns	VIH
Clock rising time	Trclk	—	6	8	ns	
Clock falling time	Tfclk	—	6	8	ns	
Horizontal blanking	Thbl	95	128	280	Clk	
Horizontal period	Th		1056		Clk	
Vertical blanking	Tvbl	32	45	184	Th	
Vertical display area	Tvd	—	480	—	Th	
DE setup time	Tes	5	-	-	ns	
DE hold time	Teh	10	-	-	ns	

Note: Above every operation range is based on stable operation

### 3.3.2.2 HV Mode

Item	Symbol	Min	Typ	Max	Unit	Remark
Clock frequency	Fck	20	33.3	42	MHZ	
Clock High time	Twch	8	—	—	ns	
Clock Low time	Twcl	8	—	—	ns	
Clock rising time	Trclk	—	—	2.5	ns	
Clock falling time	Tfclk	—	—	2.5	ns	
Hsync period	Th	895	1056	1088	Clk	
Hsync pulse width	Thw	4	-	81	Clk	
Hsync front porch	Thf	7	40	—	Clk	
Hsync back porch	Thb	7	60	84	Clk	
Hsync blanking	Thbl	95	128	280	Clk	
Hsync setup time	Ths	5			ns	
Hsync hold time	Thh	10			ns	
Vsync period	Tv	512	525	610	Th	
Vsync pulse width	Tvw	1	3	—	Th	
Vsync front porch	Tvf	—	13	—	Th	
Vsync blanking	Tvbl	32	45	184	Th	
Hsync/Vsync phase shift	Tvpd	2	320	—	Clk	
Data setup time	Tds	5			ns	
Data hold time	Tdh	10			ns	

Note: Above every operation range is based on stable operation

## 4. Optical specification

Item	Symbol	Condition	Min.	Typ.	Max.	Unit	Remark
Response Time	Rise	$\theta=0^\circ$	-	10	20	ms	Note 4
	Fall						
Contrast ratio	CR	At optimized viewing angle	200	300	-		Note 6, 7
Viewing Angle	Top	CR $\square$ 10	30	40	-	deg.	Note 8
	Bottom		50	60	-		
	Left		50	60	-		
	Right		50	60	-		
Brightness	$Y_L$	$\theta=0^\circ$	180	220	-	cd/m <sup>2</sup>	Note 9
White Chromaticity	X	$\theta=0^\circ$	0.28	0.31	0.34		
	y	$\theta=0^\circ$	0.32	0.35	0.38		

Note 1 : Ambient temperature =25℃, and lamp current  $I_L = 20\text{mA}$ . To be measured in the dark room.  
DC/AC inverter driving frequency: 70 kHz.

Note 2 :To be measured on the center area of panel with a viewing cone of 1° by Topcon luminance meter BM-5, after 15 minutes operation.

Note 3. Definition of response time:

The output signals of photo detector are measured when the input signals are changed from "black" to "white"(falling time) and from "white" to "black"(rising time), respectively.

The response time is defined as the time interval between the 10% and 90% of amplitudes.

Refer to figure as below.

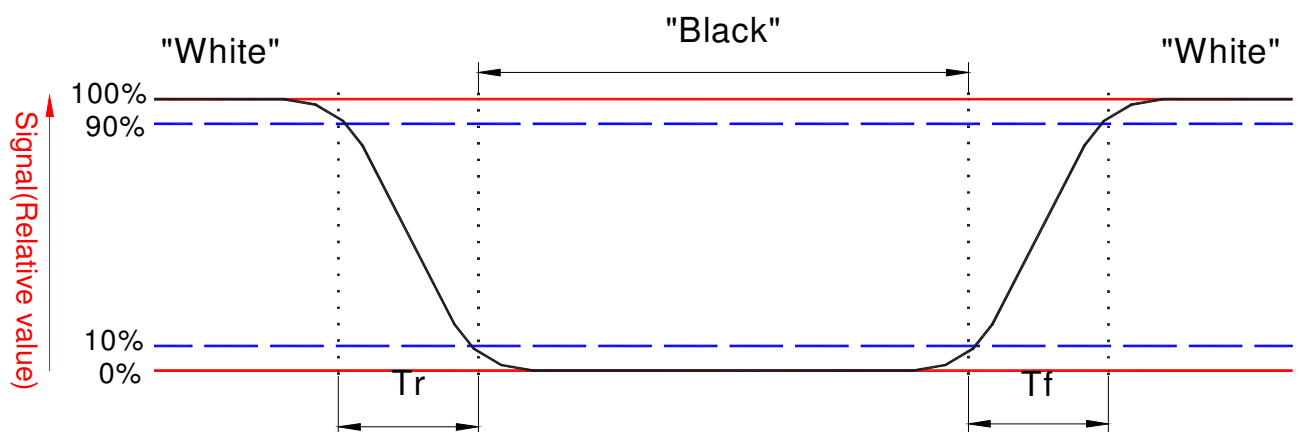

Note 4. Definition of contrast ratio:

Contrast ratio is calculated with the following formula.

$$\text{Contrast ratio (CR)} = \frac{\text{Photo detector output when LCD is at "White" state}}{\text{Photo detector output when LCD is at "Black" state}}$$

Note 5. White  $V_i = V_{i50} + 1.5V$

Black  $V_i = V_{i50} \pm 2.0V$

"±" means that the analog input signal swings in phase with VCOM signal.

"+" means that the analog input signal swings out of phase with VCOM signal.

$V_{i50}$  : The analog input voltage when transmission is 50%

The 100% transmission is defined as the transmission of LCD panel when all the input terminals of module are electrically opened.

Note 6. Definition of viewing angle, Refer to figure as below.

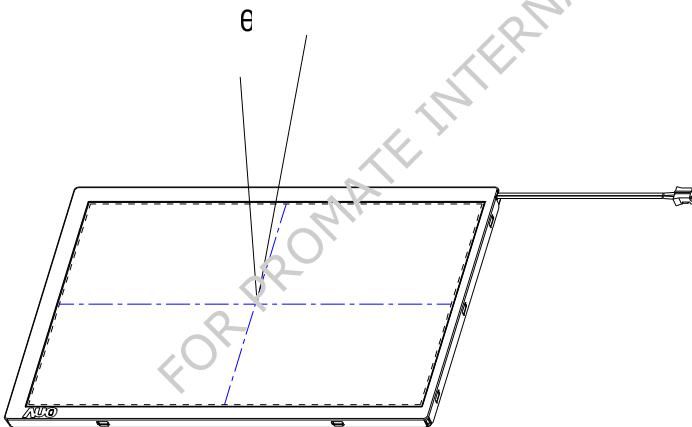

Note 7. Measured at the center area of the panel when all the input terminals of LCD panel are electrically opened.

## 5. Absolute Ratings of Ambient Environment

No.	Test items	Conditions	Remark
1	High Temperature Storage	Ta= 65□ 240Hrs	
2	Low Temperature Storage	Ta= -20□ 240Hrs	
3	High Temperature Operation	Ta= 60□ 240Hrs	
4	Low Temperature Operation	Ta= 0□ 240Hrs	
5	High Temperature & High Humidity	Ta= 50□. 80% RH 240Hrs	Operation
6	Heat Shock	-20□~60□, 50 cycle, 2Hrs/cycle	Non-operation
7	Electrostatic Discharge	±200V,200pF(0Ω), once for each terminal	Non-operation
8	Vibration	Frequency range : 10~55Hz Stroke : 1.5mm Sweep : 10 ~ 55 ~ 10Hz 2 hours for each direction of X,Y,Z (6 hours for total)	JIS C7021, A-10 condition A
9	Mechanical Shock	100G . 6ms, ±X,±Y,±Z 3 times for each direction	Non-operation JIS C7021, A-7
10	Vibration (With Carton)	Random vibration: 0.015G <sup>2</sup> /Hz from 5~200Hz	IEC 68-34
11	Drop (With Carton)	Height: 60cm 1 corner, 3 edges, 6 surfaces	

Note: Ta: Ambient Temperature.

## 6. Packing Form

