

- CONTENTS -

REVISION HISTORY	-----	3
1. GENERAL DESCRIPTION	-----	4
1.1 OVERVIEW		
1.2 FEATURES		
1.3 APPLICATION		
1.4 GENERAL SPECIFICATIONS		
1.5 MECHANICAL SPECIFICATIONS		
2. ABSOLUTE MAXIMUM RATINGS	-----	5
2.1 ABSOLUTE RATINGS OF ENVIRONMENT		
2.2 ELECTRICAL ABSOLUTE RATINGS		
2.2.1 TFT LCD MODULE		
2.2.2 BACKLIGHT UNIT		
3. ELECTRICAL CHARACTERISTICS	-----	7
3.1 TFT LCD MODULE		
3.2 BACKLIGHT UNIT		
4. BLOCK DIAGRAM	-----	10
4.1 TFT LCD MODULE		
4.2 BACKLIGHT UNIT		
5. INPUT TERMINAL PIN ASSIGNMENT	-----	11
5.1 TFT LCD MODULE		
5.2 BACKLIGHT UNIT		
5.3 COLOR DATA INPUT ASSIGNMENT		
6. INTERFACE TIMING	-----	14
6.1 INPUT SIGNAL TIMING SPECIFICATIONS		
6.2 POWER ON/OFF SEQUENCE		
7. OPTICAL CHARACTERISTICS	-----	17
7.1 TEST CONDITIONS		
7.2 OPTICAL SPECIFICATIONS		
8. PRECAUTIONS	-----	20
8.1 HANDLING PRECAUTIONS		
8.2 STORAGE PRECAUTIONS		
8.3 OPERATION PRECAUTIONS		
9. PACKAGING	-----	21
9.1 PACKING SPECIFICATIONS		
9.2 PACKING METHOD		
10. INCOMING INSPECTION DAY	-----	23
11. DEFINITION OF LABELS	-----	24

REVISION HISTORY

Version	Date	Page (New)	Section	Description
Ver 1.0	Nov.23'2001	All	All	Issue Preliminary Specification
Ver 2.0	Apr.26'2002	17	7.2	Revising Center Luminance of White(L) TBD(Min.)→280(Min.) Revising Color Chromaticity Red(Rx) 0.618(Min.)/0.648(Typ.)/0.678(Max.) →0.611(Min.)/0.641(Typ.)/0.671(Max.) Revising Color Chromaticity Red(Ry) 0.323(Min.)/0.353(Typ.)/0.383(Max.) →0.329(Min.)/0.359(Typ.)/0.389(Max.) Revising Color Chromaticity Green(Gx) 0.259(Min.)/0.289(Typ.)/0.319(Max.) →0.258(Min.)/0.288(Typ.)/0.318(Max.) Revising Color Chromaticity Green(Gy) 0.562(Min.)/0.592(Typ.)/0.622(Max.) →0.568(Min.)/0.598(Typ.)/0.628(Max.) Revising Color Chromaticity Blue(Bx) 0.121(Min.)/0.151(Typ.)/0.181(Max.) →0.117(Min.)/0.147(Typ.)/0.177(Max.) Revising Color Chromaticity Blue(By) 0.099(Min.)/0.129(Typ.)/0.159(Max.) →0.095(Min.)/0.125(Typ.)/0.155(Max.)

1. GENERAL DESCRIPTION

1.1 OVERVIEW

M150X2-T06 is a 15.0" TFT Liquid Crystal Display module with 4 CCFL Backlight units and 60 pins TTL interface. This module supports 1024 x 768 XGA mode and can display 262,144 colors. The optimum viewing angle is at 6 o'clock direction. The inverter module for Backlight is not built in.

1.2 FEATURES

- Wide viewing angle
- XGA (1024 x 768 pixels) resolution
- DE (Data Enable) only mode
- High contrast 500:1 Typ.
- TTL Interface with 2pixels/clock

1.3 APPLICATION

- Desktop monitors

1.4 GENERAL SPECIFICATIONS

Item	Specification	Unit	Note
Active Area	304.1(H) x 228.1(V) (15.0" diagonal)	mm	(1)
Bezel Opening Area	308.2(H) x 232.1(V)	mm	
Driver Element	a-si TFT active matrix	-	-
Pixel Number	1024 x R.G.B. x 768	pixel	-
Pixel Pitch	0.297(H) x 0.297(W)	mm	-
Pixel Arrangement	RGB vertical stripe	-	-
Display Colors	262,144	color	-
Transmissive Mode	Normally black	-	-

1.5 MECHANICAL SPECIFICATIONS

Item	Min.	Typ.	Max.	Unit	Note
Module Size	Horizontal(H)	-	331.6	mm	(1)
	Vertical(V)	-	254.76	mm	
	Depth(D)	-	13.0	mm	(1)(2)
Weight	-	-	1,350	g	-

Note (1) Please refer to the attached drawings for more information of front and back outline dimensions.

Note (2) The depth is without connector and boss.

2. ABSOLUTE MAXIMUM RATINGS

2.1 ABSOLUTE RATINGS OF ENVIRONMENT

Item	Symbol	Value		Unit	Note
		Min.	Max.		
Storage Temperature	T _{ST}	-20	+60	°C	(1)
Operating Ambient Temperature	T _{OP}	0	+50	°C	(1), (2)
Storage Humidity	H _{ST}	5	85	%	-
Operation Humidity	H _{OP}	20	85	%	-
Shock (Non-Operating)	S _{NOP}	-	50	G	(3), (5)
Vibration (Non-Operating)	V _{NOP}	-	2	G	(4), (5)

Note (1) Temperature and relative humidity range is shown in the figure below.

- (a) 85 %RH Max. (Ta ≤ 40 °C).
- (b) Wet-bulb temperature should be 39 °C Max. (Ta > 40 °C).
- (c) No condensation of water.

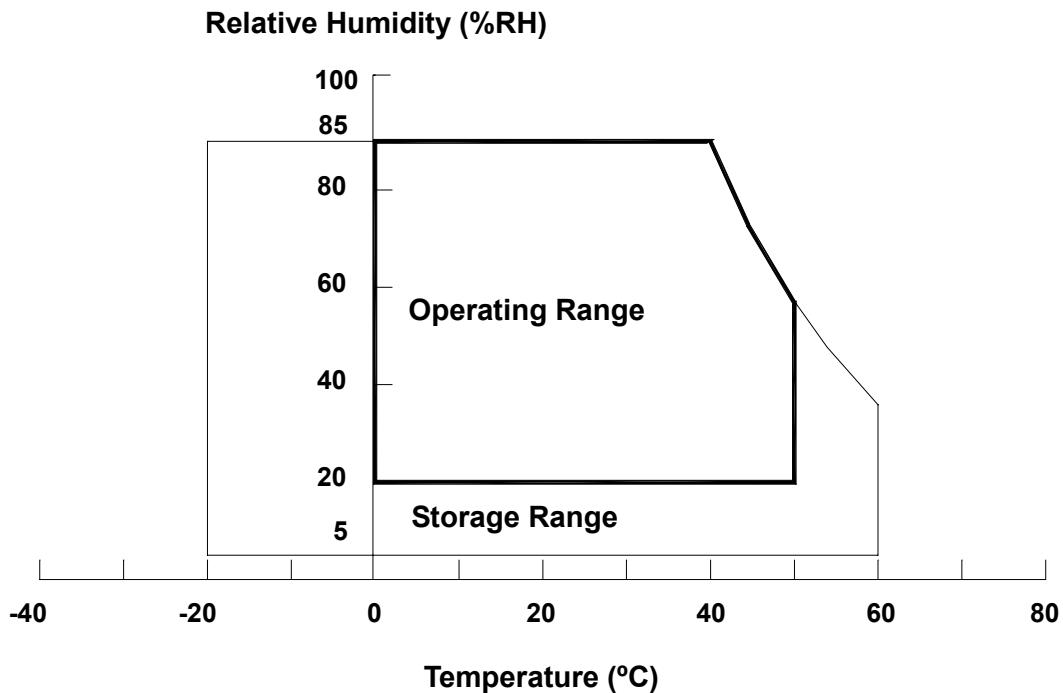

Note (2) The temperature of panel surface should be 0 °C Min. and 60 °C Max.

Note (3) 6ms, 1 time each ±X, ±Y and ±Z directions

Note (4) 10 ~ 500 Hz, 1 cycle/20min. 1.5mm max, 1 hour each X, Y and Z directions

Note (5) At testing Vibration and Shock, the fixture in holding the module has to be hard and rigid enough so that the module would not be twisted or bent by the fixture.

2.2 ELECTRICAL ABSOLUTE RATINGS

2.2.1 TFT LCD MODULE

Item	Symbol	Value		Unit	Note
		Min.	Max.		
Power Supply Voltage	V _{DD}	-0.3	4.0	V	(1)

2.2.2 BACKLIGHT UNIT

Item	Symbol	Value		Unit	Note
		Min.	Max.		
Lamp Voltage	V _L	553	676	V _{RMS}	(1), (2), I _L = 6.5 mA
Lamp Current	I _L	2.0	7.0	mA _{RMS}	(1), (2)
Lamp Frequency	F _L	30	80	KHZ	

Note (1) Permanent damage to the device may occur if maximum values are exceeded. Function operation should be restricted to the conditions described under Normal Operating Conditions.

Note (2) Specified values are for lamp (Refer to Section 3.2 for further information).

3. ELECTRICAL CHARACTERISTICS

3.1 TFT LCD MODULE

Parameter	Symbol	Value			Unit	Note	
		Min.	Typ.	Max.			
Power Supply Voltage	V_{DD}	3.0	3.3	3.6	V	-	
Rush Current	I_{RUSH}	-	-	1.5	A	(2)	
Power Supply Current	White	-	750	800	mA	(3)a	
	Black	-	440	470	mA	(3)b	
	Vertical Stripe	-	540	570	mA	(3)c	
Input Voltage	"H" Level	V_{IH}	2.4	-	3.6	V	-
	"L" Level	V_{IL}	0	-	0.9	V	-

Note (1) The module should be always operated within above ranges.

Note (2) Measurement Conditions:

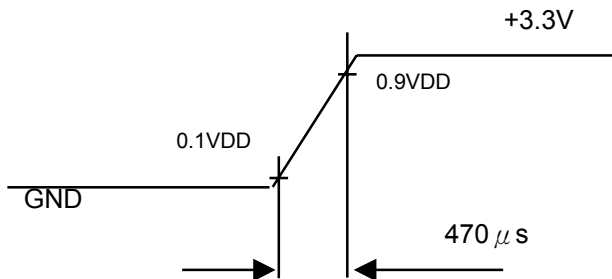
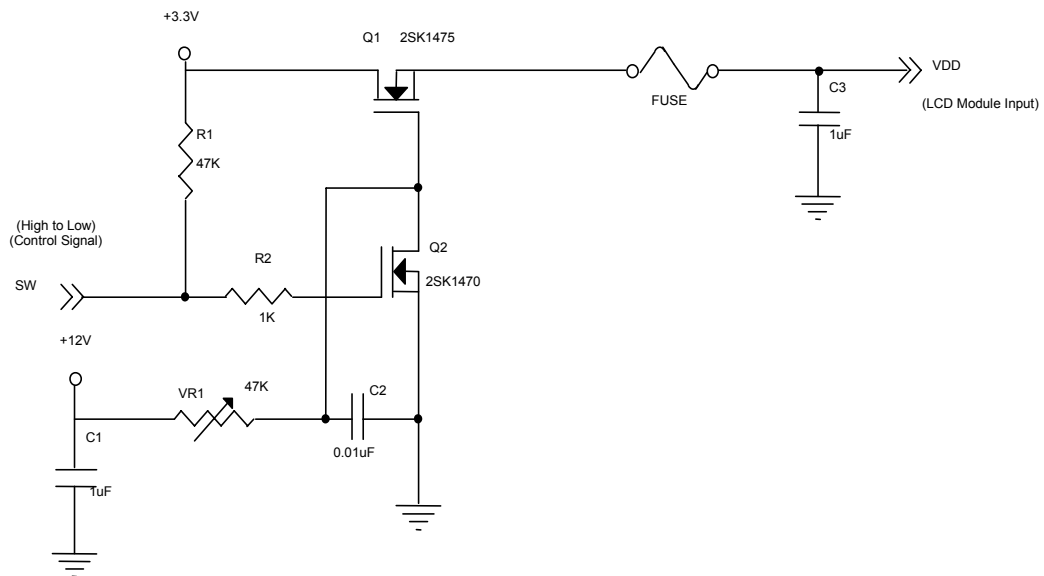

Note (3) The specified power supply current is under the conditions at $V_{DD} = 3.3V$, $T_a = 25 \pm 2 \text{ }^\circ\text{C}$, DC Current and $f_v = 60 \text{ Hz}$, whereas a power dissipation check pattern below is displayed.

a. White Pattern

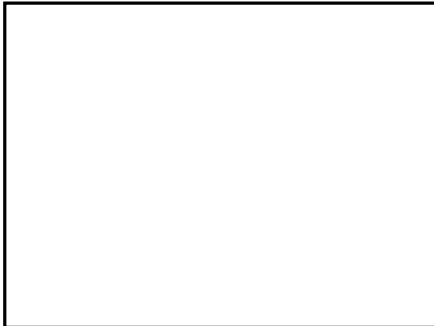

Active Area

b. Black Pattern



Active Area

c. Vertical Stripe Pattern

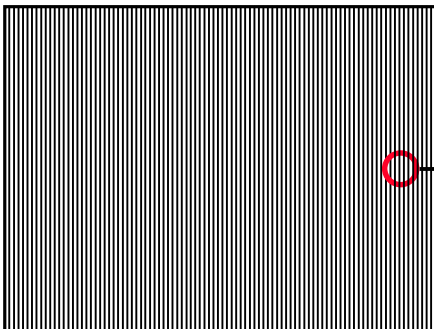

Active Area

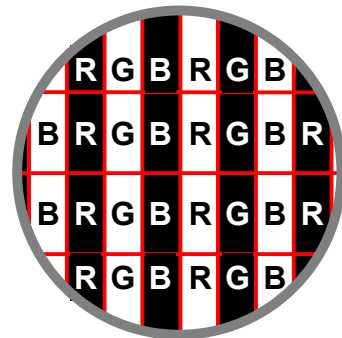

3.2 BACKLIGHT UNIT

$T_a = 25 \pm 2 \text{ }^\circ\text{C}$

Parameter	Symbol	Value			Unit	Note
		Min.	Typ.	Max.		
Lamp Input Voltage	V_L	553	615	676	V_{RMS}	$I_L = 6.5 \text{ mA}$
Lamp Current	I_L	2.0	6.5	7.0	mA_{RMS}	(1)
Lamp Turn On Voltage	V_s	-	-	850 (25 $^\circ\text{C}$)	V_{RMS}	(2)
		-	-	1050 (0 $^\circ\text{C}$)	V_{RMS}	(2)
Operating Frequency	F_L	30	45	80	KHz	(3)
Lamp Life Time	L_{BL}	40,000	50,000	-	Hrs	(5)
Power Consumption	P_L	-	16000	-	mW	(4), $I_L = 6.5 \text{ mA}$

Note (1) Lamp current is measured by utilizing a high frequency current meter as shown below:

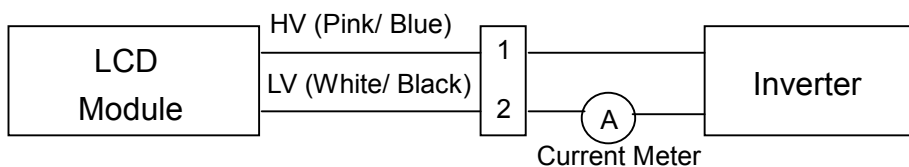

Note (2) The voltage shown above should be applied to the lamp for more than 1 second after startup. Otherwise the lamp may not be turned on.

Note (3) The lamp frequency may generate interference with horizontal synchronous frequency from the display, and this may cause line flow on the display. In order to avoid interference, the lamp frequency should be detached from the horizontal synchronous frequency and its harmonics as far as possible.

Note (4) $P_L = I_L \times V_L$

Note (5) The lifetime of lamp is defined as the time when it continues to operate under the conditions at $T_a = 25 \pm 2 \text{ }^\circ\text{C}$ and $I_L = 7.0\text{mA}_{\text{RMS}}$ until one of the following events occurs:

(a) When the brightness becomes $\leq 50\%$ of its original value.

(b) When the effective ignition length becomes $\leq 80\%$ of its original value. (Effective ignition length is defined as an area that the brightness is less than 70% compared to the center point.)

Note (6) The waveform of the voltage output of inverter must be area-symmetric and the design of the inverter must have specifications for the modularized lamp. The performance of the Backlight, such as lifetime or brightness, is greatly influenced by the characteristics of the DC-AC inverter for the lamp. All the parameters of an inverter should be carefully designed to avoid generating too much current leakage from high voltage output of the inverter. When designing or ordering the inverter please make sure that a poor lighting caused by the mismatch of the Backlight and the inverter (miss-lighting, flicker, etc.) never occurs. If the above situation is confirmed, the module should be operated in the same manners when it is installed in your instrument.

4. BLOCK DIAGRAM

4.1 TFT LCD MODULE

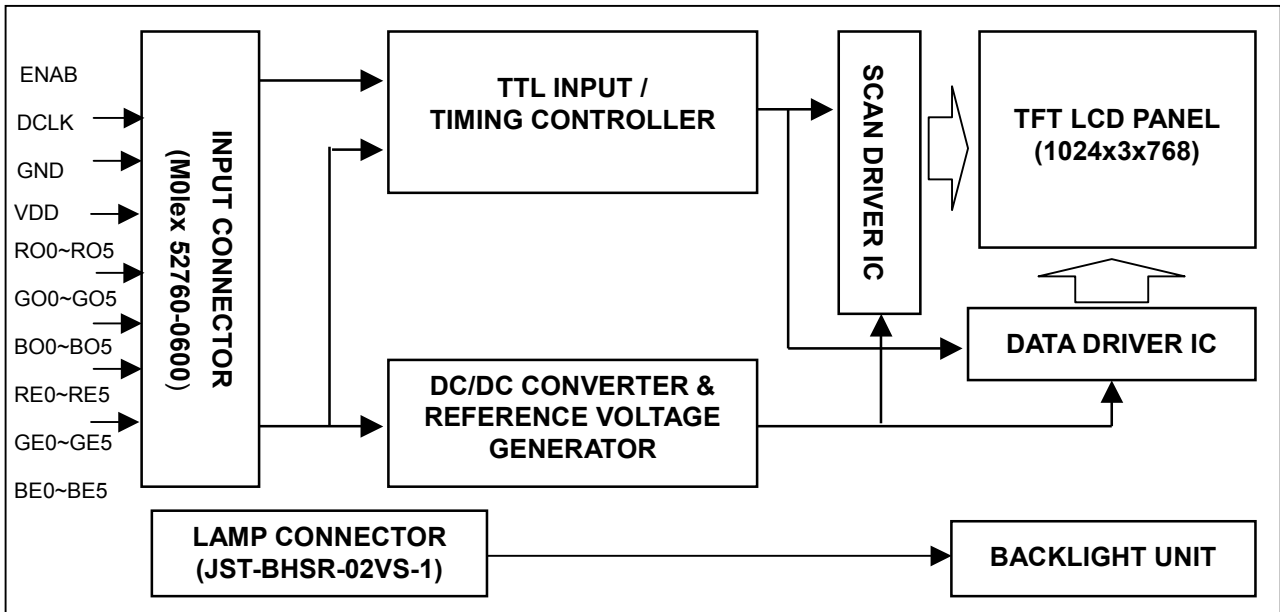

4.2 BACKLIGHT UNIT

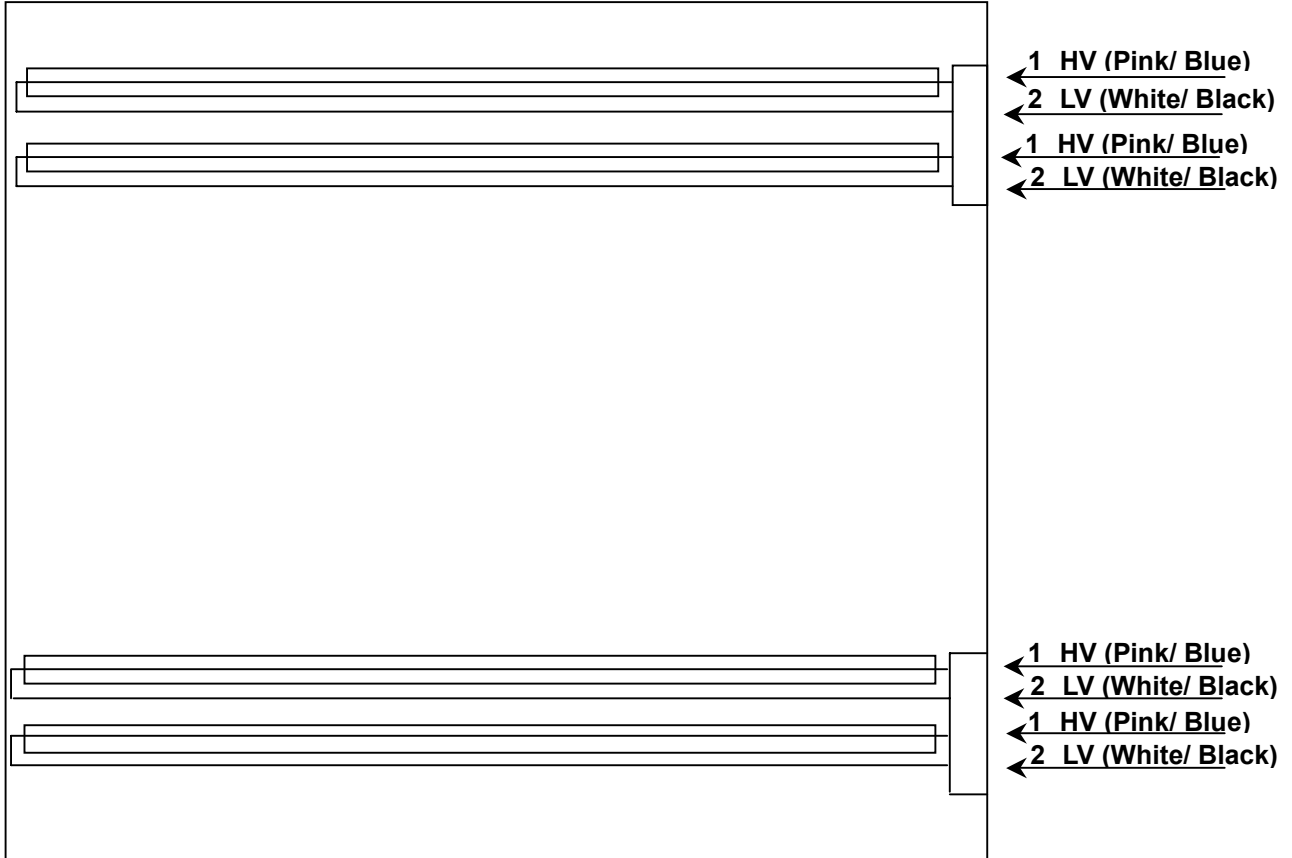

5. INPUT TERMINAL PIN ASSIGNMENT

5.1 TFT LCD MODULE

Pin No.	Symbol	I/O	Function	Pin No.	Symbol	I/O	Function
1	GND	-	Ground	31	GE1	I	Green even data 1
2	RO0	I	Red odd data 0	32	GE2	I	Green even data 2
3	RO1	I	Red odd data 1	33	GE3	I	Green even data 3
4	RO2	I	Red odd data 2	34	GE4	I	Green even data 4
5	RO3	I	Red odd data 3	35	GE5	I	Green even data 5
6	RO4	I	Red odd data 4	36	GND	-	Ground
7	RO5	I	Red odd data 5	37	BE0	I	Blue even data 0
8	GND	-	Ground	38	BE1	I	Blue even data 1
9	GO0	I	Green odd data 0	39	BE2	I	Blue even data 2
10	GO1	I	Green odd data 1	40	BE3	I	Blue even data 3
11	GO2	I	Green odd data 2	41	BE4	I	Blue even data 4
12	GO3	I	Green odd data 3	42	BE5	I	Blue even data 5
13	GO4	I	Green odd data 4	43	GND	-	Ground
14	GO5	I	Green odd data 5	44	PULL	I	Must be fixed to 0 V
15	GND	-	Ground	45	PULL	I	Must be fixed to 0 V
16	BO0	I	Blue odd data 0	46	ENAB	I	Data enable signal
17	BO1	I	Blue odd data 1	47	GND	-	Ground
18	BO2	I	Blue odd data 2	48	GND	-	Ground
19	BO3	I	Blue odd data 3	49	DCLK	I	Dot clock signal
20	BO4	I	Blue odd data 4	50	GND	-	Ground
21	BO5	I	Blue odd data 5	51	GND	-	Ground
22	GND	-	Ground	52	NC	-	Must be floating
23	RE0	I	Red even data 0	53	NC	-	Must be floating
24	RE1	I	Red even data 1	54	GND	-	Ground
25	RE2	I	Red even data 2	55	GND	-	Ground
26	RE3	I	Red even data 3	56	GND	-	Ground
27	RE4	I	Red even data 4	57	V _{DD}	-	+3.3V Power supply
28	RE5	I	Red even data 5	58	V _{DD}	-	+3.3V Power supply
29	GND	-	Ground	59	V _{DD}	-	+3.3V Power supply
30	GE0	I	Green even data 0	60	V _{DD}	-	+3.3V Power supply

Connector Part No.: 52760-0600(Molex)

User's connector Part No: 53475-0600(Molex)

Correspondence between Data and Display Position

	S0001	S0002	S0003	S0004	S0005	S0006	S0007	S0008	-----	S3071	S3072
C001	RE	GE	BE	RO	GO	BO	RE	GE		GO	BO
	0001	0001	0001	0002	0002	0002	0003	0003		1024	1024
C768	RE	GE	BE	RO	GO	BO	RE	GE		GO	BO
	0001	0001	0001	0002	0002	0002	0003	0003		1024	1024

5.2 BACKLIGHT UNIT

Pin	Symbol	Description	Color
1	HV1	High Voltage	Pink/ Blue
2	LV	Ground	White/ Black

Note (1) Connector Part No.: BHSR-02VS-1 (JST) or equivalent

Note (2) Matching Connector Part No.: SM02B-BHS-1-TB (JST) or equivalent

5.3 COLOR DATA INPUT ASSIGNMENT

The brightness of each primary color (red, green and blue) is based on the 6-bit gray scale data input for the color. The higher the binary input the brighter the color. The table below provides the assignment of color versus data input.

Color		Data Signal																	
		Red						Green						Blue					
		R5	R4	R3	R2	R1	R0	G5	G4	G3	G2	G1	G0	B5	B4	B3	B2	B1	B0
Basic Colors	Black	0	0	0	0	0	0	0	0	0	0	0	0	0	0	0	0	0	0
	Red	1	1	1	1	1	1	0	0	0	0	0	0	0	0	0	0	0	0
	Green	0	0	0	0	0	0	1	1	1	1	1	1	0	0	0	0	0	0
	Blue	0	0	0	0	0	0	0	0	0	0	0	0	1	1	1	1	1	1
	Cyan	0	0	0	0	0	0	1	1	1	1	1	1	1	1	1	1	1	1
	Magenta	1	1	1	1	1	1	0	0	0	0	0	0	1	1	1	1	1	1
	Yellow	1	1	1	1	1	1	1	1	1	1	1	1	0	0	0	0	0	0
	White	1	1	1	1	1	1	1	1	1	1	1	1	1	1	1	1	1	1
Gray Scale Of Red	Red(0) / Dark	0	0	0	0	0	0	0	0	0	0	0	0	0	0	0	0	0	0
	Red(1)	0	0	0	0	0	1	0	0	0	0	0	0	0	0	0	0	0	0
	Red(2)	0	0	0	0	1	0	0	0	0	0	0	0	0	0	0	0	0	0
	⋮	⋮	⋮	⋮	⋮	⋮	⋮	⋮	⋮	⋮	⋮	⋮	⋮	⋮	⋮	⋮	⋮	⋮	⋮
	⋮	⋮	⋮	⋮	⋮	⋮	⋮	⋮	⋮	⋮	⋮	⋮	⋮	⋮	⋮	⋮	⋮	⋮	⋮
	Red(61)	1	1	1	1	0	1	0	0	0	0	0	0	0	0	0	0	0	0
	Red(62)	1	1	1	1	1	0	0	0	0	0	0	0	0	0	0	0	0	0
	Red(63)	1	1	1	1	1	1	0	0	0	0	0	0	0	0	0	0	0	0
Gray Scale Of Green	Green(0) / Dark	0	0	0	0	0	0	0	0	0	0	0	0	0	0	0	0	0	0
	Green(1)	0	0	0	0	0	0	0	0	0	0	0	1	0	0	0	0	0	0
	Green(2)	0	0	0	0	0	0	0	0	0	0	1	0	0	0	0	0	0	0
	⋮	⋮	⋮	⋮	⋮	⋮	⋮	⋮	⋮	⋮	⋮	⋮	⋮	⋮	⋮	⋮	⋮	⋮	⋮
	⋮	⋮	⋮	⋮	⋮	⋮	⋮	⋮	⋮	⋮	⋮	⋮	⋮	⋮	⋮	⋮	⋮	⋮	⋮
	Green(61)	0	0	0	0	0	0	1	1	1	1	0	1	0	0	0	0	0	0
	Green(62)	0	0	0	0	0	0	1	1	1	1	1	0	0	0	0	0	0	0
	Green(63)	0	0	0	0	0	0	1	1	1	1	1	1	0	0	0	0	0	0
Gray Scale Of Blue	Blue(0) / Dark	0	0	0	0	0	0	0	0	0	0	0	0	0	0	0	0	0	0
	Blue(1)	0	0	0	0	0	0	0	0	0	0	0	0	0	0	0	0	0	1
	Blue(2)	0	0	0	0	0	0	0	0	0	0	0	0	0	0	0	0	1	0
	⋮	⋮	⋮	⋮	⋮	⋮	⋮	⋮	⋮	⋮	⋮	⋮	⋮	⋮	⋮	⋮	⋮	⋮	⋮
	⋮	⋮	⋮	⋮	⋮	⋮	⋮	⋮	⋮	⋮	⋮	⋮	⋮	⋮	⋮	⋮	⋮	⋮	⋮
	Blue(61)	0	0	0	0	0	0	0	0	0	0	0	0	1	1	1	1	0	1
	Blue(62)	0	0	0	0	0	0	0	0	0	0	0	0	1	1	1	1	1	0
	Blue(63)	0	0	0	0	0	0	0	0	0	0	0	0	1	1	1	1	1	1

Note (1) 0: Low Level Voltage, 1: High Level Voltage

6. INTERFACE TIMING

6.1 INPUT SIGNAL TIMING SPECIFICATIONS

The input signal timing specifications are shown as the following table and timing diagram.

Signal	Parameter	Symbol	Min	Typ	Max	Unit	Remarks
DCLK	Pixel clock Frequency	Fck	-	32.5	40	MHz	
	Pixel clock period	Tck	25	30	40	ns	
	Duty ratio (%Tch)	-	45	50	55	%	Tch/Tck
	High time	Tckh	5	-	-	ns	
	Low time	Tckl	5	-	-	ns	
DATA	Setup time	Tsd	4	-	-	ns	
	Hold time	Thd	4	-	-	ns	
DE	Setup time	Tsde	4	-	-	ns	
	Hold time	Thde	4	-	-	ns	
Vertical Signal	Vertical Frequency	Fv	-	60	75	Hz	
	Vertical display active period	Tvda	768	768	768	Thp	
	Vertical display blank period	Tvdb	1	38	-	Thp	
	Vertical period	Tvp	769	806	-	Thp	
Horizontal Signal	Horizontal display active period	Thda	512	512	512	Tck	
	Horizontal display blank period	Thdb	38	160	388	Tck	
	Horizontal period	Thp	550	672	900	Tck	

Note (1) Because this module is operated by DE only mode, Hsync and Vsync input signals should be set to low logic level or ground. Otherwise, this module would operate abnormally.

INPUT SIGNAL TIMING DIAGRAM

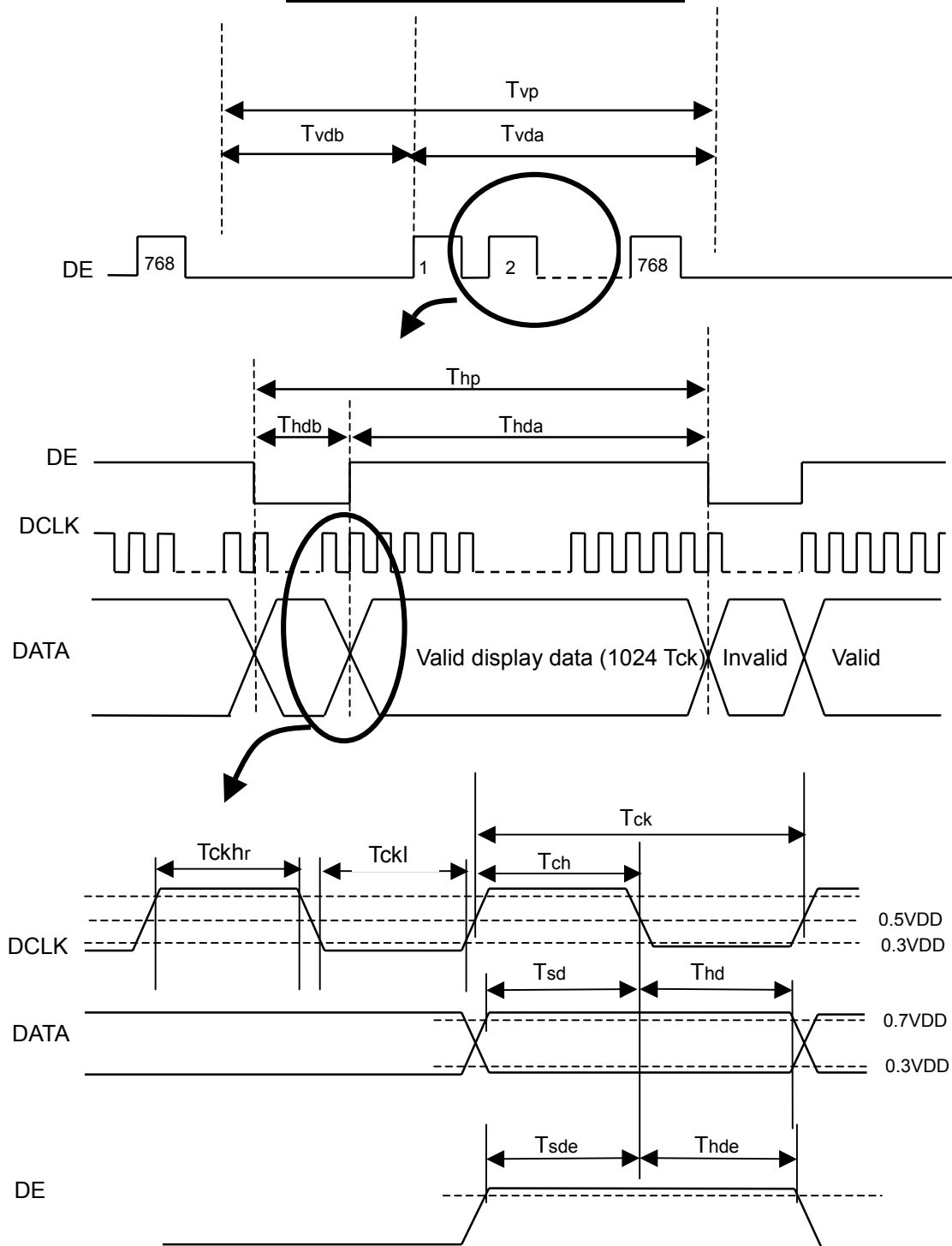

6.2 POWER ON/OFF SEQUENCE

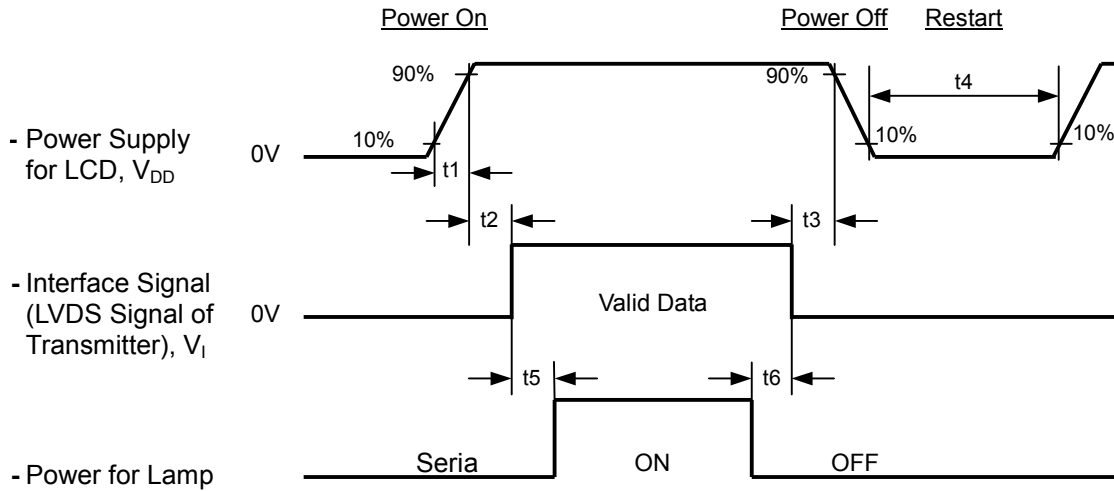

Timing Specifications:

- $0 < t1 \leq 10 \text{ msec}$
- $0 < t2 \leq 50 \text{ msec}$
- $0 < t3 \leq 50 \text{ msec}$
- $t4 \geq 1 \text{ sec}$
- $t5 \geq 100 \text{ msec}$
- $t6 \geq 100 \text{ msec}$

Note (1) Please avoid floating state of interface signal at invalid period.

Note (2) When the interface signal is invalid, be sure to pull down the power supply of LCD V_{DD} to 0 V.

Note (3) The Backlight inverter power must be turned on after the power supply for the logic and the interface signal is valid. The Backlight inverter power must be turned off before the power supply for the logic and the interface signal is invalid.

7. OPTICAL CHARACTERISTICS

7.1 TEST CONDITIONS

Item	Symbol	Value	Unit
Ambient Temperature	T _a	25±2	°C
Ambient Humidity	H _a	50±10	%RH
Supply Voltage	V _{DD}	3.3	V
Input Signal	According to typical value in "3. ELECTRICAL CHARACTERISTICS"		
Inverter Current	I _L	6.5	mA

The measurement methods of optical characteristics are shown in Section 7.2. The following items should be measured under the test conditions described in Section 7.1 and stable environment shown in Note (4).

7.2 OPTICAL SPECIFICATIONS

Item		Symbol	Condition	Min.	Typ.	Max.	Unit	Note
Contrast Ratio		CR	$\theta_x=0^\circ, \theta_y=0^\circ$ Viewing Normal Angle	350	500	-	-	(2), (4)
Response Time		T _R		-	15	30	ms	(3)
		T _F		-	10	25	ms	
Center Luminance of White		L		280	350	-	cd/m ²	(4)
Color Chromaticity	Red	R _x		0.611	0.641	0.671	-	(1), (4)
		R _y		0.329	0.359	0.389	-	
	Green	G _x		0.258	0.288	0.318	-	
		G _y		0.568	0.598	0.628	-	
	Blue	B _x		0.117	0.147	0.177	-	
		B _y		0.095	0.125	0.155	-	
	White	W _x	0.280	0.310	0.340	-		
		W _y	0.300	0.330	0.360	-		
Viewing Angle	Horizontal	θ_{x+}	CR≥10	80	85	-	Deg.	
		θ_{x-}		80	85	-		
	Vertical	θ_{y+}		80	85	-		
		θ_{y-}		80	85	-		

Note (1) Definition of Viewing Angle (θ_x, θ_y):

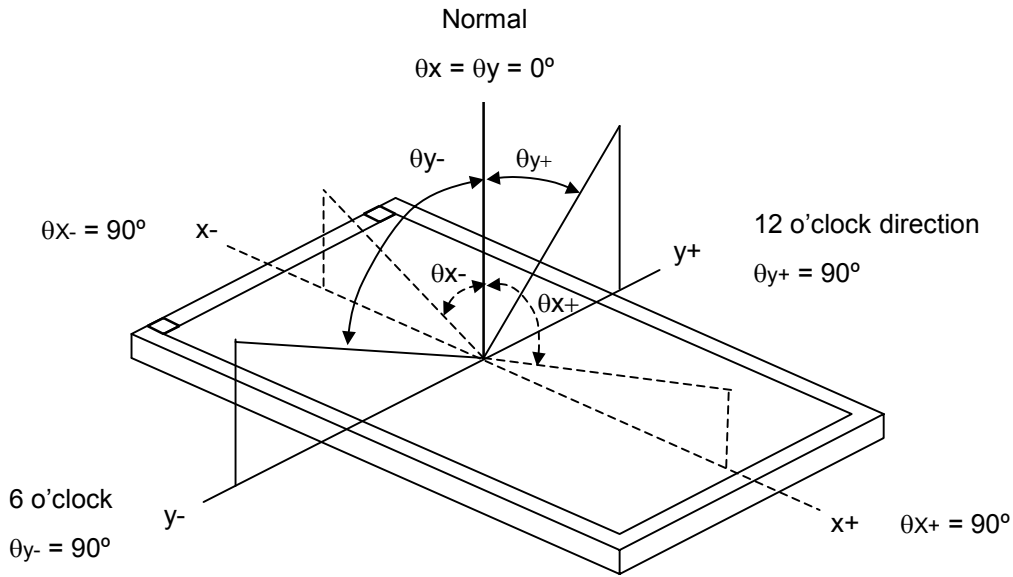

Note (2) Definition of Contrast Ratio (CR):

The contrast ratio can be calculated by the following expression.

$$\text{Contrast Ratio (CR)} = L_{63} / L_0$$

L63: Luminance of gray level 63

L 0: Luminance of gray level 0

$$\text{CR} = \text{CR} (5)$$

CR (X) is corresponding to the Contrast Ratio of the point X at Figure in Note (5).

Note (3) Definition of Response Time (T_R, T_F):

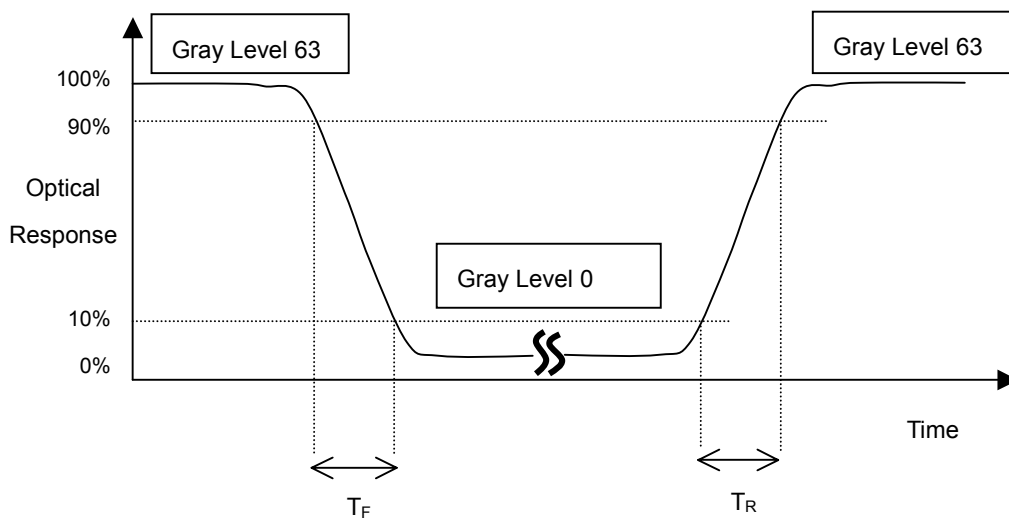

Note (4) Measurement Setup:

The LCD module should be stabilized at given temperature for 20 minutes to avoid abrupt temperature change during measuring. In order to stabilize the luminance, the measurement should be executed after lighting Backlight for 20 minutes in a windless room.

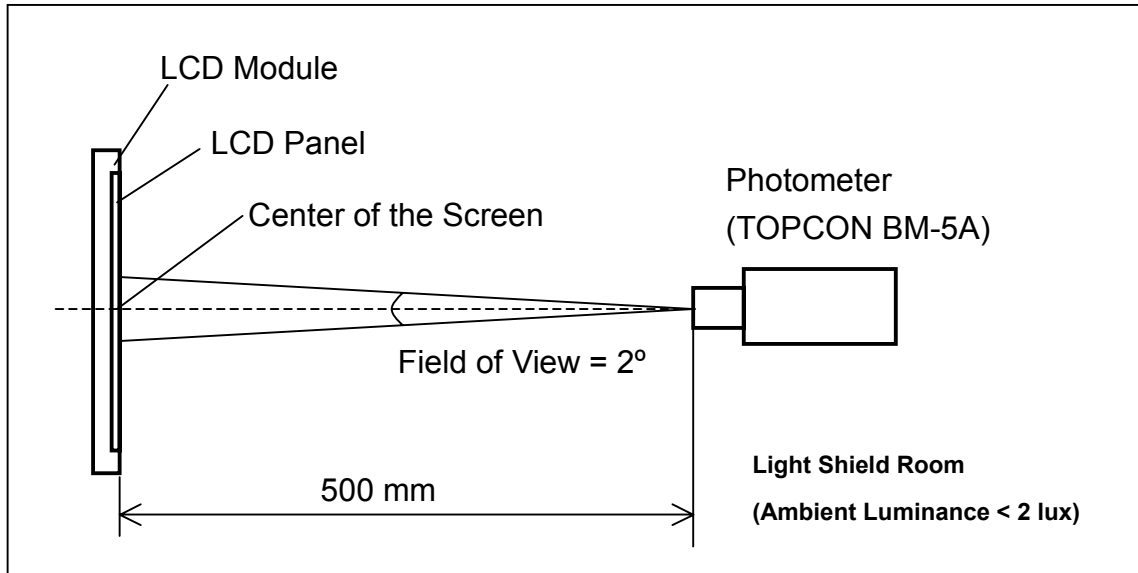

Note (5) Definition of luminance uniformity measured points:

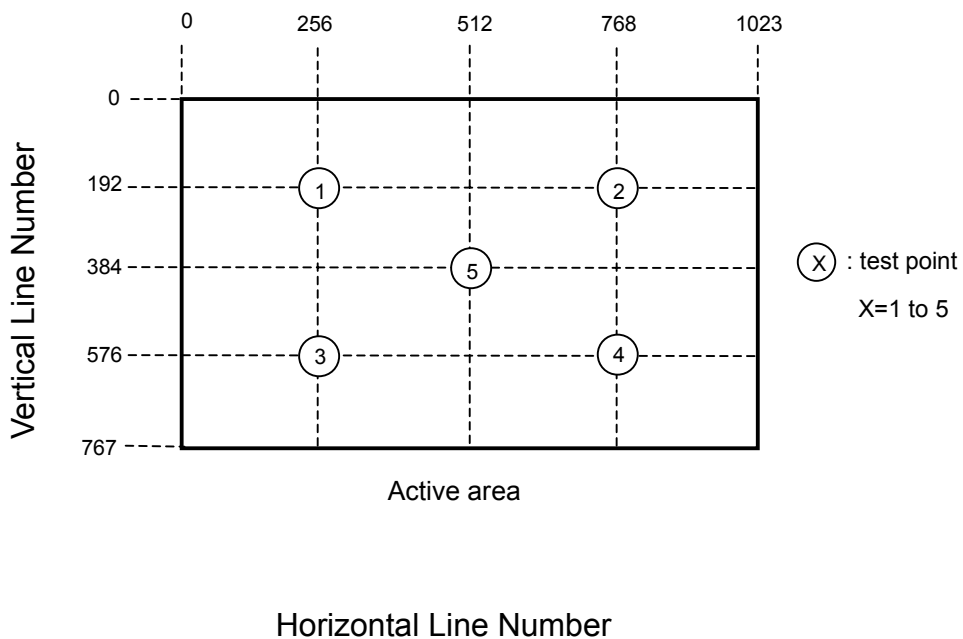

8. PRECAUTIONS

8.1 HANDLING PRECAUTIONS

- (1) The module should be assembled into the system firmly by using every mounting hole. Be careful not to twist or bend the module.
- (2) While assembling or installing modules, it can only be in the clean area. The dust and oil may cause electrical short or damage the polarizer.
- (3) Use fingerstalls or soft gloves in order to keep display clean during the incoming inspection and assembly process.
- (4) Do not press or scratch the surface harder than a HB pencil lead on the panel because the polarizer is very soft and easily scratched.
- (5) If the surface of the polarizer is dirty, please clean it by some absorbent cotton or soft cloth. Do not use Ketone type materials (ex. Acetone), Ethyl alcohol, Toluene, Ethyl acid or Methyl chloride. It might permanently damage the polarizer due to chemical reaction.
- (6) Wipe off water droplets or oil immediately. Staining and discoloration may occur if they left on panel for a long time.
- (7) If the liquid crystal material leaks from the panel, it should be kept away from the eyes or mouth. In case of contacting with hands, legs or clothes, it must be washed away thoroughly with soap.
- (8) Protect the module from static electricity, it may cause damage to the C-MOS Gate Array IC.
- (9) Do not disassemble the module.
- (10) Do not pull or fold the lamp wire.
- (11) Pins of I/F connector should not be touched directly with bare hands.

8.2 STORAGE PRECAUTIONS

- (1) High temperature or humidity may reduce the performance of module. Please store LCD module within the specified storage conditions.
- (2) It is dangerous that moisture come into or contacted the LCD module, because the moisture may damage LCD module when it is operating.
- (3) It may reduce the display quality if the ambient temperature is lower than 10 °C. For example, the response time will become slowly, and the starting voltage of lamp will be higher than the room temperature.

8.3 OPERATION PRECAUTIONS

- (1) Do not pull the I/F connector in or out while the module is operating.
- (2) Always follow the correct power on/off sequence when LCD module is connecting and operating. This can prevent the CMOS LSI chips from damage during latch-up.
- (3) The startup voltage of Backlight is approximately 1000 Volts. It may cause electrical shock while assembling with inverter. Do not disassemble the module or insert anything into the Backlight unit.

9. PACKAGING

9.1 PACKING SPECIFICATIONS

- (1) 5 LCD modules / 1 Box
- (2) Box dimensions : 353(L) X 268(W) X 462(H) mm
- (3) Weight : approximately 8.5Kg (5 modules per box)

9.2 PACKING Method

Figures 9-1 and 9-2 are the packing method.

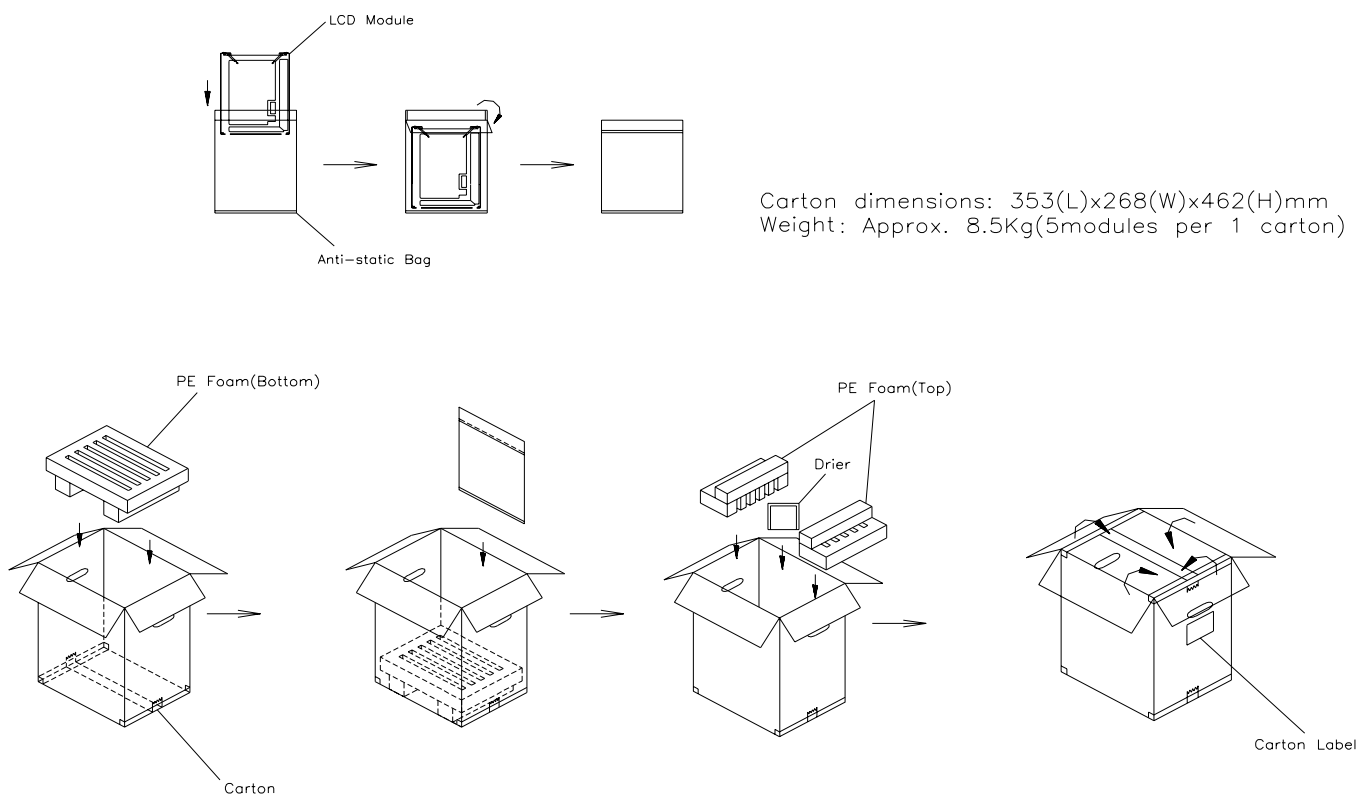

Figure. 9-1 Packing method

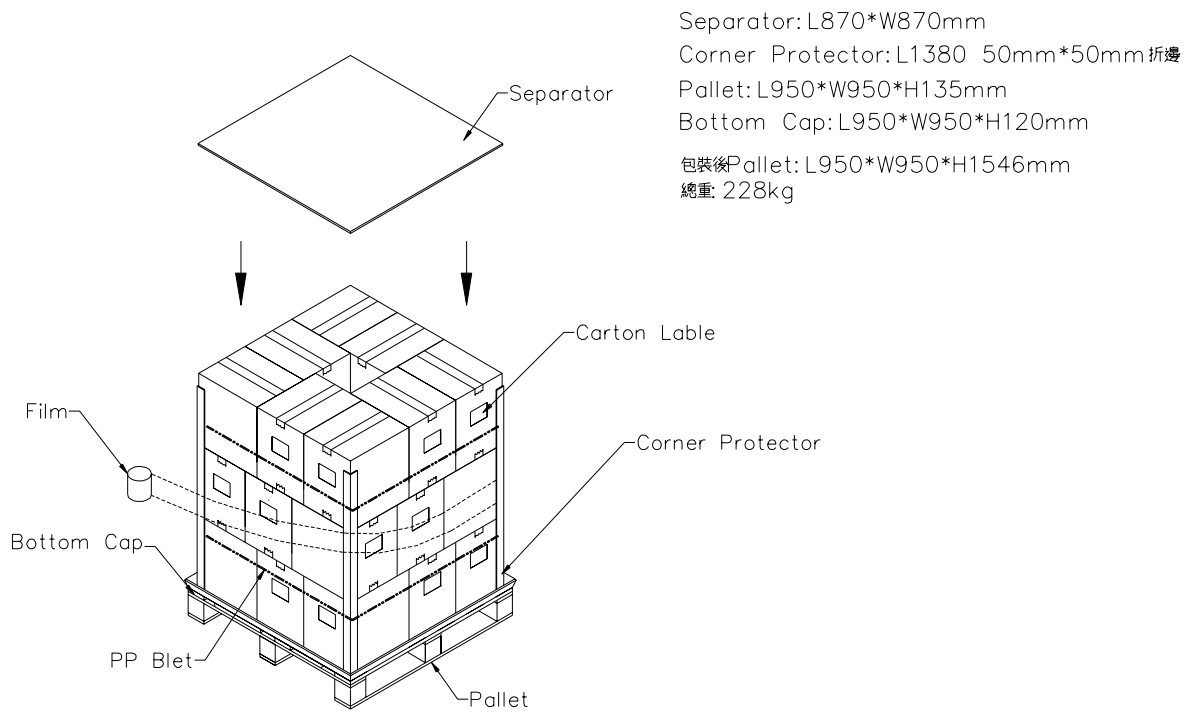

Figure. 9-2 Packing method

10. INCOMING INSPECTION DAY

The Supplier should be acquainted the inspection results (acceptance or rejection) by Customer, and the results are in accordance with the incoming inspection standard within 30 days after the date of the bills of lading.

Should Customer fail to so notify the Supplier within the said 30 days period. The Customer's right to reject the LCMS shall then lapse, and the said LCMS shall be deemed to have been accepted by the customer.

11. DEFINITION OF LABELS

11.1 CMO MODULE LABEL

The barcode nameplate is pasted on each module as illustration, and its definitions are as following explanation.

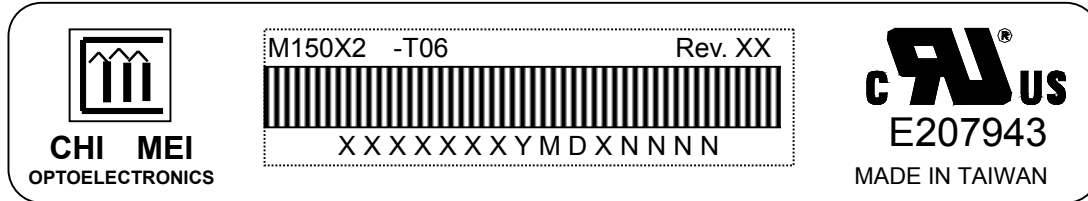

- (a) Model Name: M150X2 -T06
- (b) Revision: Rev. XX, for example: C1, C2 ...etc.
- (c) Serial ID: XXXXXXXXYMDXNNNN

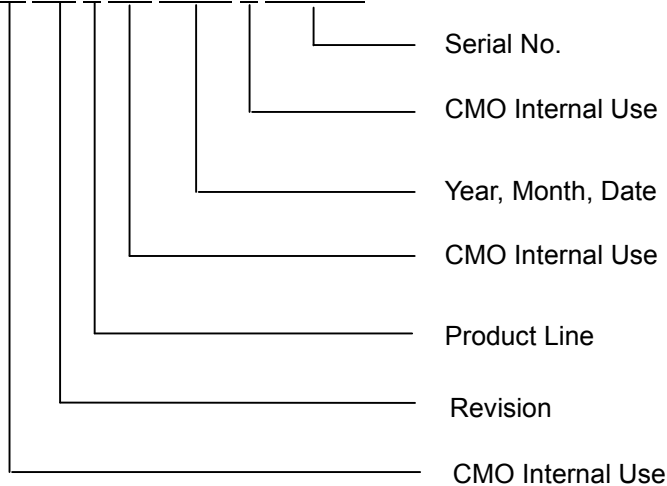

Serial ID includes the information as below:

- (a) Manufactured Date: Year: 1~9, for 2000~2009
Month: 1~9, A~C, for Jan. ~ Dec.
Day: 1~9, A~Y, for 1st to 31st, exclude I and O
- (b) Revision Code: cover all the change
- (c) Serial No.: Manufacturing sequence of product
- (d) CMO Internal Use: 1 -> Line1, 2 -> Line 2, ...etc.

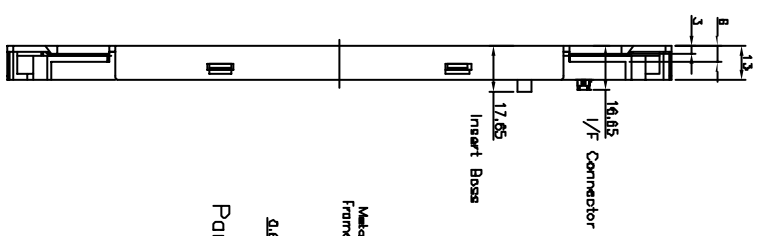
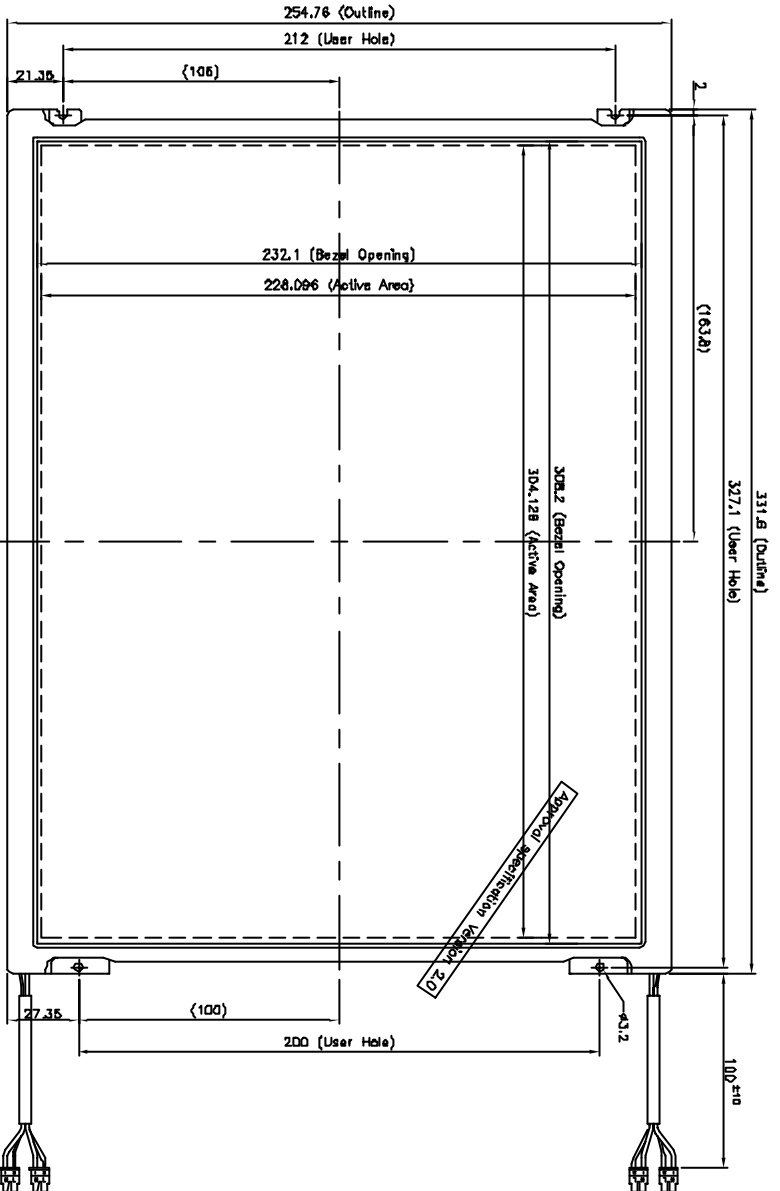

Panel Section

NOTES:
1. GENERAL TOLERANCE: ±0.5

CHI MEI
OPTOELECTRONICS CORP.

APPROVED:	DAVIS WANG	DWG NO.:	M15014122A
CHECKED:	CHANLEY CHEN	DATE:	04/26/2002
DESIGNER:	DAVIS WANG	PART NO.:	MPDX201908
DRAWER:	DAVIS WANG	DEPT.:	A
TITLE:		DWIT:	SCALE:
Outline M150X2-T06		MM	1:2
			1/2

MARK	DESCRIPTION	DATE	CHANGED BY	APPROVAL BY	ECN NO.

CHI MEI COPYRIGHT 2002, ALL RIGHTS RESERVED, COPYING FORBIDDEN.

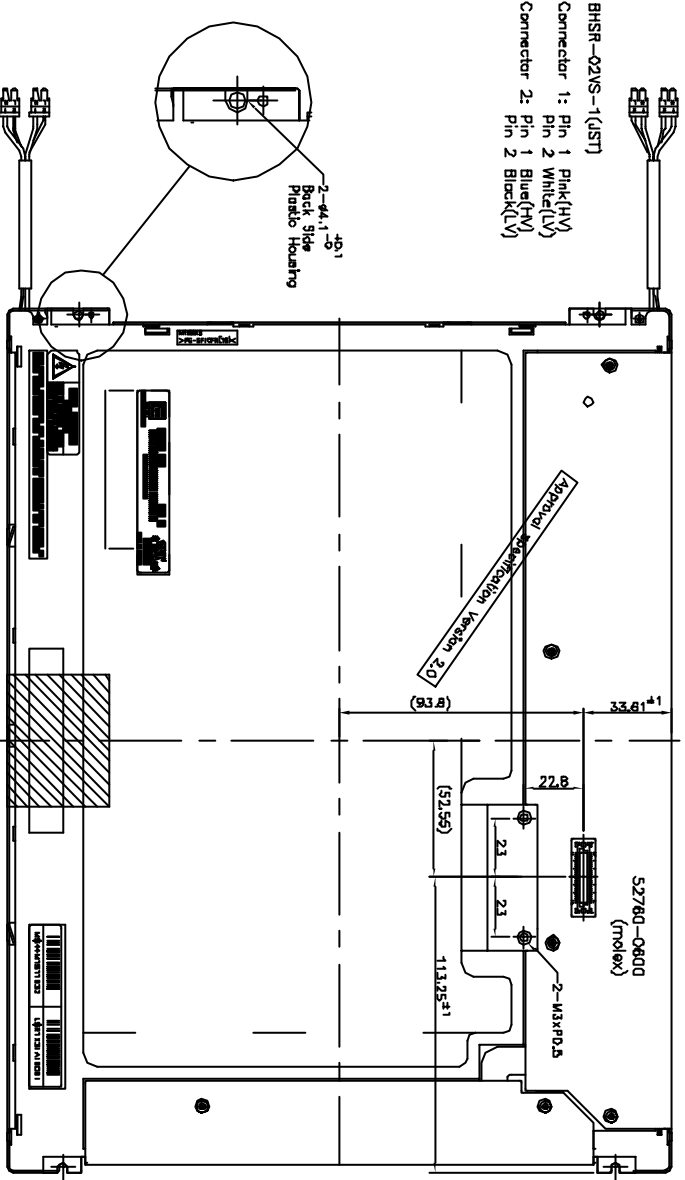

NOTES:
 1. GENERAL TOLERANCE: ±0.5
 2. INSERT BASS TORQUE 2.0~2.5kgf-cm

CHI MEI
 OPTOELECTRONICS CORP.

APPROVED:	DAVIS WANG	DWG NO.:	M15014122A
CHECKED:	CHANLEY CHEN	DATE:	04/26/2002
DESIGNER:	DAVIS WANG	PART NO.:	MPDX201908
DRAWER:	DAVIS WANG	DEPT.:	A
TITLE:		UNIT:	MM
Outline M150X2-T06		SCALE:	1:2
		SHEET:	2/2

MARK	DESCRIPTION	DATE	CHANGE BY	APPROVAL BY	ECN NO.
B		7		B	
		4			
		3			
		2			
		1			

CHI MEI COPYRIGHT 2002, ALL RIGHTS RESERVED, COPYING FORBIDDEN.