

To : \_\_\_\_\_

## Specification of FUJITSU TFT-LCD module

**FLC51UXC8V-10L**

Approval

Date :

By :

This Product is designed, developed and manufactured as contemplated for general use, including without limitation, general office use, personal use, household use, and ordinary industrial use, but is not designed, developed and manufactured as contemplated for use accompanying fatal risks or dangers that, unless extremely high safety is secured, could lead directly to death, personal injury, severe physical damage or other loss (hereinafter "High Safety Required Use"), including without limitation, nuclear reaction control in nuclear facility, aircraft flight control, air traffic control, mass transport control, medical life support system, missile launch control in weapon system. If customer's product possibly falls under the category of High Safety Required Use, please consult with our sales representatives in charge before such use. In addition, Fujitsu shall not be liable against the Customer and/or any third party for any claims or damages arising in connection with the High Safety Required Use of the Product without permission.

Specification No. : Tech Bes LCD-00239

Issue Date : September 14, 2004

Issued by :



Katsunori. Tanaka  
Project Director  
LCD Products Div.

FUJITSU DISPLAY TECHNOLOGIES CORPORATION



# TABLE OF CONTENTS

1. APPLICATIONS	3
2. PRODUCT NAME AND MODEL NUMBER	3
2-1.Product Names	3
2-2.Model Numbers	3
3. OVERVIEW	3
4. CONFIGURATION	3
5. MECHANICAL SPECIFICATIONS	4
6. ABSOLUTE MAXIMUM RATING	5
7. RECOMMENDED OPERATING CONDITIONS	5
8. ELECTRICAL SPECIFICATIONS	6
9. OPTICAL SPECIFICATIONS	8
10. INTERFACE SPECIFICATIONS	12
10-1.Signal Descriptions	12
10-2.LVDS Data Assignment	13
10-3. Color Data Assignment	14
10-4. Input Signal Timing	15
10-5. Correspondence between Data and Display Position	17
10-6.Power Supply Sequence	17
11. BACK-LIGHT SPECIFICATIONS	18
11-1.Pin configurations for Back-light	18
11-2.CCFL	18
11-3.Life	18
12. APPEARANCE SPECIFICATIONS	19
12-1.Appearance	19
12-2.Dot defects	20
13. ENVIRONMENTAL SPECIFICATIONS	21
14. INDICATIONS	22
15. PACKAGING	22
15-1.Packing Specifications	22
15-2.Packing Method	23
16. WARRANTY	27
17. PRECAUTIONS	27
18. OTHERS	33

A

A

B

B

C

C

D

D

E

DOCUMENT CONTROL SECTION

DATE

						TITLE <b>FLC51UXC8V-10</b>	
						DRAW. NO. <b>Tech Bes-LCD00239</b>	
						CUST.	
EDIT	DATE	DESIG.	CHECK	APPR.	DESCRIPTION	FUJITSU DISPLAY TECHNOLOGIES CORPORATION	
DESIG.			CHECK		APPR.	2/	

F

**1. APPLICATION**

This specification is applied to the 20.1-inch UXGA supported TFT-LCD module.

A

A

**2. PRODUCT NAME AND MODEL NUMBER**

2-1 Product Name: **LCD Module**

2-2 Model Name: **FLC51UXC8V-10L**

**3. OVERVIEW**

This LCD module has a TFT active matrix type liquid crystal panel 1600x1200 pixels, and diagonal size of 51cm (20.1-inch). This LCD has a LVDS dual interface and can display 16,777,216 colors.

The power supply of this LCD module is +12V DC single.

This module has the characteristics for applying TCO'99.

B

B

C

C

**4. CONFIGURATION**

This LCD module consists of a color TFT-LCD panel that is mounted with TFT driver ICs, a cold-cathode fluorescent tube back-light.

The inverter for the backlight is not included.

Figure 4-1 shows a block diagram of this LCD module.

D

D

DATE	
DOCUMENT CONTROL SECTION	

E

F

						TITLE		FLC51UXC8V-10	
						DRAW. NO.		Tech Bes-LCD00239	
						CUST.			
EDIT	DATE	DESIG.	CHECK	APPR.	DESCRIPTION		FUJITSU DISPLAY TECHNOLOGIES CORPORATION		3/
	DESIG.		CHECK			APPR.			

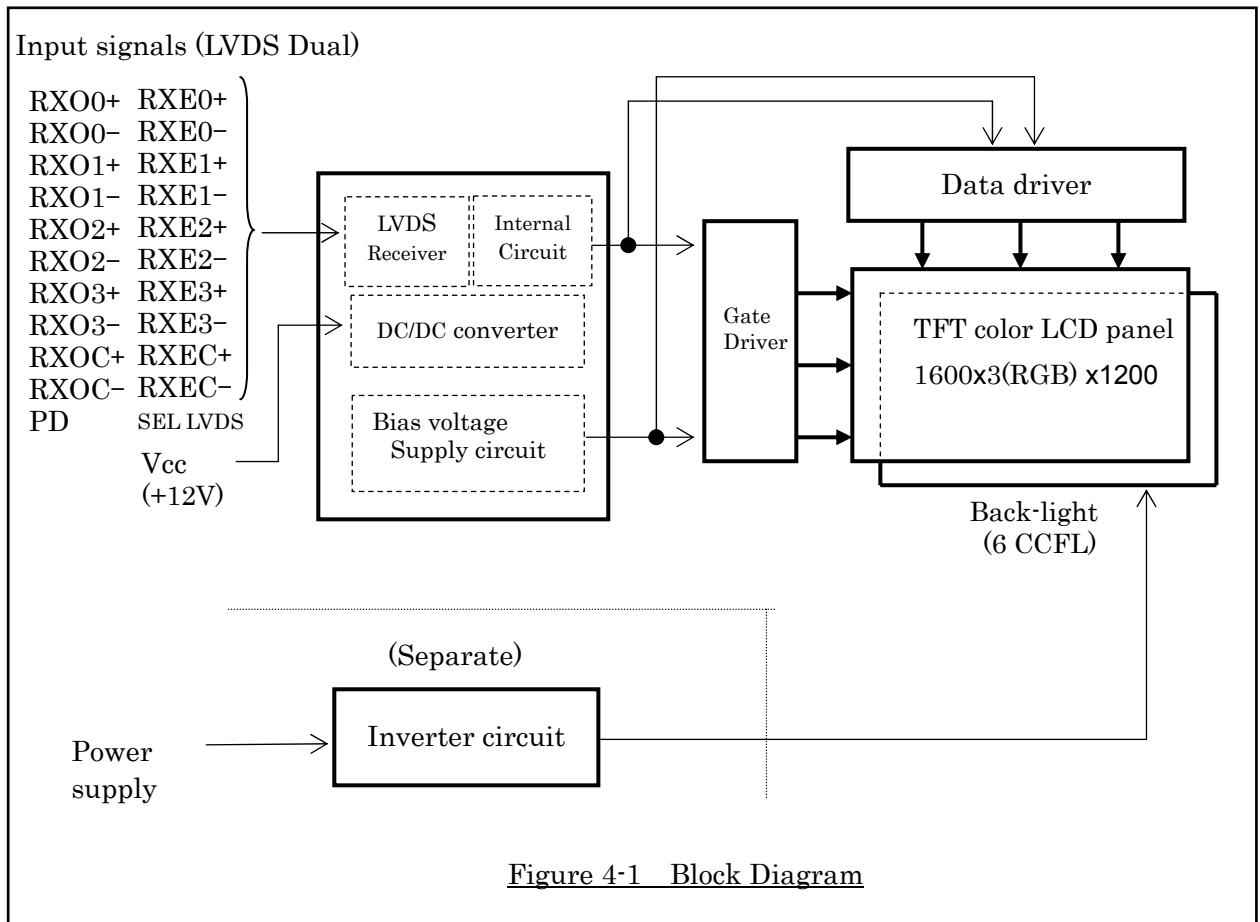

Figure 4-1 Block Diagram

## 5. MECHANICAL SPECIFICATIONS

Table 5-1 shows the mechanical specifications of this LCD module.

Table 5-1 Mechanical Specifications

Item	Specifications	Unit	Remark
Dimensions	432 x 331.5 x 25(TYP.)	mm	Edge type back-light is used. (φ 2.6 CCFLx6)
Display Resolution	(1600x3) x 1200	—	
Display Dot Area	408.0 x 306.0	mm	For details on dimensions, See dimensional outline drawing. (At page 34,35)
Dot Pitch	(0.085x3) x 0.255	mm	
Aspect Ratio	1:1	—	
Weight	3,500 (Max)	g	Excluding inverter.
FG-SG	Short circuit	—	

DOCUMENT CONTROL SECTION

DATE

						TITLE FLC51UXC8V-10	
						DRAW. NO. Tech Bes-LCD00239	
						CUST.	
EDIT	DATE	DESIG.	CHECK	APPR.	DESCRIPTION		
DESIG.			CHECK		FUJITSU DISPLAY TECHNOLOGIES CORPORATION		
						4 /	

A

### 6. ABSOLUTE MAXIMUM RATING

Table 6-1 shows the absolute maximum rating of this LCD module.

Table 6-1 Absolute Maximum Rating

Item	Symbol	Condition	MIN.	TYP.	MAX.	Unit
Supply Voltage	V <sub>CC</sub>	Ta=25°C	-0.3	—	14.0	V
Input Signal Voltage (LVDS signal, PD, SEL LVDS)	V <sub>IN</sub>	Ta=25°C	-0.3	—	3.6	V

B

### 7. RECOMMENDED OPERATING CONDITIONS

Table 7-1 shows the recommended operating conditions of this LCD module.

Table 7-1 Recommended Operating Conditions

Item	Symbol	MIN.	TYP.	MAX.	Unit
Supply Voltage (Logic)	V <sub>CC</sub>	11.5	12.0	12.5	V
Ripple Voltage	V <sub>CC</sub>	V <sub>RP</sub>	—	0.1	V

C

D

DOCUMENT CONTROL SECTION

DATE

A

B

C

D

E

F

						TITLE	FLC51UXC8V-10	
						DRAW. NO.	Tech Bes-LCD00239	CUST.
EDIT	DATE	DESIG.	CHECK	APPR.	DESCRIPTION	FUJITSU DISPLAY TECHNOLOGIES CORPORATION		5/
	DESIG.		CHECK		APPR.			

## 8. ELECTRICAL SPECIFICATIONS

Table 8-1 shows the electrical specifications of this LCD module. Figure 8-1 shows the measurement circuit. Figure 8-2(A) shows the equivalent circuit of the logic signal input area. Figure 8-2(B) shows the equivalent circuit of the supply voltage Input area.

Table 8-1 Electrical Specifications

Item	Symbol	Condition	MIN.	TYP.	MAX.	Unit	Remark	
Differential-input Voltage (High)	$V_{IH}$	$V_{CM}=+1.2V$	—	—	100	mV		
Differential-input Voltage (Low)	$V_{IL}$		-100	—	—	mV		
Supply Current	$I_{CC}$	$V_{CC}=+12.0\pm 0.5V$ $V_{SS}=0V$ $DCLK=81MHz$ $60Hz$	—	500	1000	mA	*1	
Supply Rush Current	$I_{SCC}$		—	—	5.8	A	*2	
Supply Rush Current Duration (1A excess)	$T_{SCC}$		—	—	0.2.	ms		
BACK LIGHT (*3)	CCFL Turn on Voltage	$V_S$	$f_L=50kHz,$ $T_a=25^\circ C$	—	1600	1800	Vrms	*4
			$f_L=50kHz,$ $T_a=0^\circ C$	—	—	1850	Vrms	*4
	Lighting Voltage	$V_L$	$f_L=50kHz$ $I_L=6mA$	—	800	—	Vrms	
	Lighting Frequency	$f_L$	$V_L=800Vrms$	30	50	60	KHz	
	Tube Current	$I_L$	$f_L=50kHz$ $V_L=800Vrms$	3	6	7	mArms	*3

(\*1) Typical current situation : Color bar pattern.  $V_{CC}=12.0V$   
Maximum current situation: White screen.  $V_{CC}=11.5V$   
Without rush current.

(\*2) These items prescribe the rush current for starting internal DC/DC.  
Charging current to capacitors of  $V_{CC}$  is not prescribed.

(\*3) Tube current ( $I_L$ ) shows the value of the current that is consumed at one lamp.  
This LCD module has 6 lamps. Each 3 lamps are placed at upper side and lower side of the display.  
3 lamps are connected in parallel. Each low voltage terminals are connected with separate Cable to Back-light connector.

(\*4) The voltage above this value should be applied to the lamp for more than 1 second to startup.  
Otherwise the lamp may not be turned on.

DOCUMENT CONTROL SECTION

DATE

						TITLE FLC51UXC8V-10	
						DRAW. NO. Tech Bes-LCD00239	
						CUST.	
EDIT	DATE	DESIG.	CHECK	APPR.	DESCRIPTION		
DESIG.			CHECK		FUJITSU DISPLAY TECHNOLOGIES CORPORATION		
						6/	



# 9. OPTICAL SPECIFICATIONS

Table 9-1 shows the optical specifications of this LCD module.

Table 9-1 Optical Specifications

Ta=25°C,Signal timing=Typ.

Item	Symbol	Condition	Specifications			Unit	Remark		
			MIN.	TYP.	MAX.				
Visual Angle	Horizontal	$\theta_{L,R}$	CR $\geq$ 10	$\theta_{U,D}=0^\circ$	85	—	—	deg	(1)(2) (3)(5) (6)
	Vertical	$\theta_{U,D}$		$\theta_{L,R}=0^\circ$	85	—	—	deg	
	All Direction	$\theta$			—	80	—	deg	
Contrast Ratio	CR	$\theta_{L,R,U,D}=0^\circ$		400	600	—	—	White/Black	(1)(2) (3)(5)
③ Response Time (Rise+Fall) (B→W→B)	$\tau_{rise} + \tau_{fall}$	$\theta_{L,R,U,D}=0^\circ$	Ta=25°C	—	16	—	ms	White*1	(1) (4) (5)
			Ta=0°C	—	34	—	ms		
Brightness	I	$\theta_{L,R,U,D}=0^\circ$	V <sub>CC</sub> =12.0V I <sub>L</sub> =6mA f <sub>L</sub> =50kHz R*,G*,B*Signal =All"H"	200	250	—	cd/m <sup>2</sup>	White*1	(1)(5)
Brightness Uniformity	$\Delta I$			70	—	—	%		(1)(5) (7)
Chromaticity	W	x		0.283	0.313	0.343	—		(1) (5)
		y		0.299	0.329	0.359	—		
	R G B	(x, y)	Red	(0.641,0.350) Typ.					
			Green	(0.287,0.595) Typ.					
			Blue	(0.142,0.070) Typ.					
LCD Panel Type				TFT Color					
Display Mode				Normally Black					
Wide Viewing Angle Technology				MVA					
Optimum Viewing Angle				— (Symmetry)				(6)	
Display Color				16,777,216 (8-bit color)					
Color of non-display area				Black					
Surface Treatment				Anti-glare (Haze value:(25%), 2H)					

(\*1) Value at 15~20 minutes after lighting on.

(Note) •CS-1000 (MINOLTA Co. Ltd.) , Field=1° , L=500mm

•Back-light current = 6mA, Dark room condition (1 lux or less)

•Be careful that the luminance meter, which you use, may not be able to get correct brightness

If it's no set correctly.

DOCUMENT CONTROL SECTION

DATE

						TITLE		FLC51UXC8V-10L	
						DRAW. NO.		Tech Bes LCD-00239	
						CUST.			
03		20040914				Revised response time			
EDIT	DATE	DESIG.	CHECK	APPR.	DESCRIPTION		FUJITSU DISPLAY TECHNOLOGIES CORPORATION		8 /
DESIG.			CHECK			APPR.			

Note 1) Definition of Viewing Angle (1)

Based on Figure 9-1.

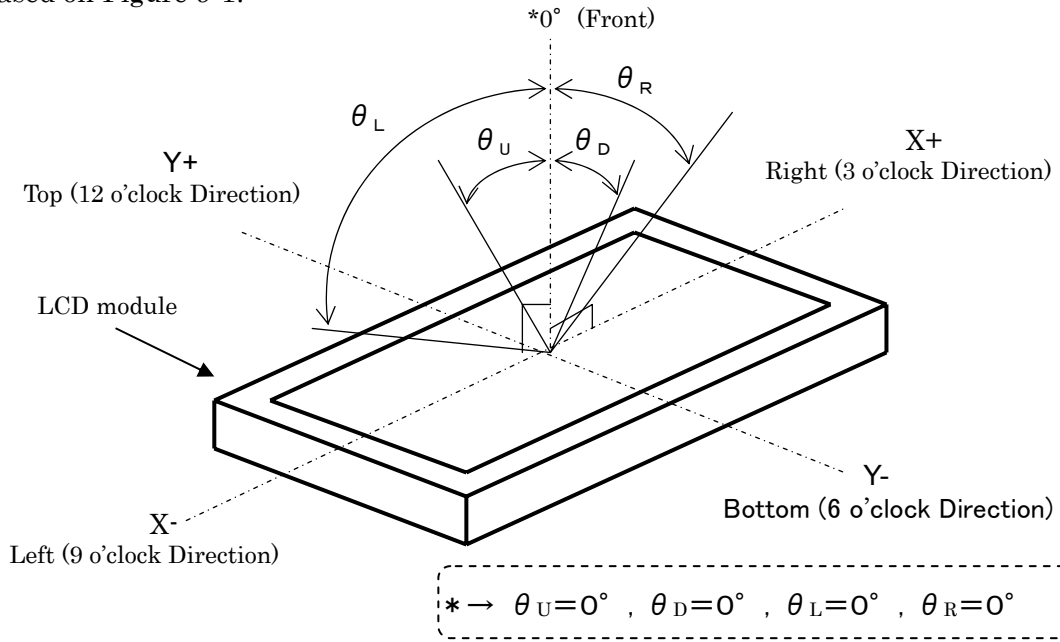

Figure 9-1 Definition of Viewing Angle (1)

Note 2) Definition of Viewing Angle (2)

Based on Figure 9-2.

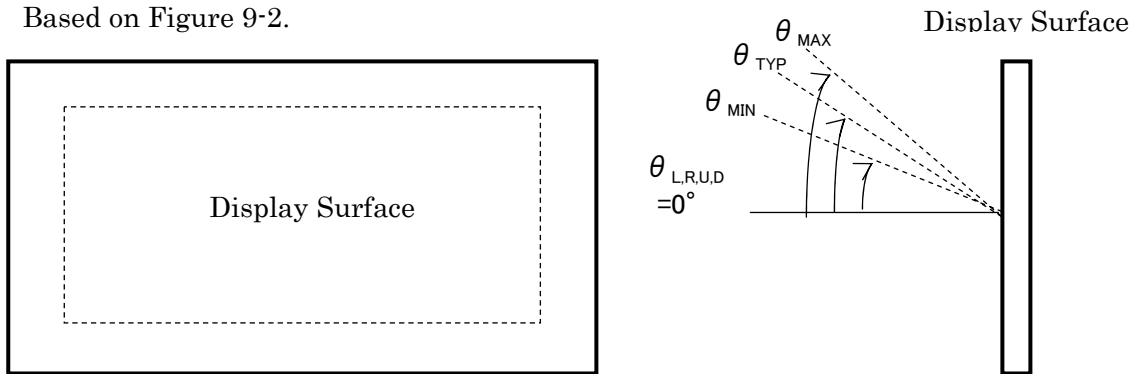

Figure 9-2 Definition of Viewing Angle (2)

Note 3) Definition of Contrast Ratio (CR)

Determined by Formula (1) based on Figure 9-3 Voltage-Brightness characteristics.

$$= \frac{L_W \text{ (Brightness at white)}}{L_B \text{ (Brightness at black)}} \dots\dots(1)$$

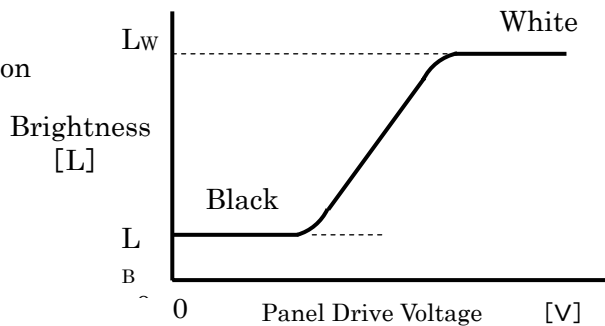

Figure 9-3 Voltage-Brightness Characteristics

DOCUMENT CONTROL SECTION
DATE

						TITLE FLC51UXC8V-10L	
						DRAW. NO. Tech Bes LCD-00239	
						CUST. 	
EDIT	DATE	DESIG.	CHECK	APPR.	DESCRIPTION	FUJITSU DISPLAY TECHNOLOGIES CORPORATION	
DESIG.			CHECK		APPR.	9 /	

ⓈNote 4) Definition of Response Time

Based on Figure 9-4.

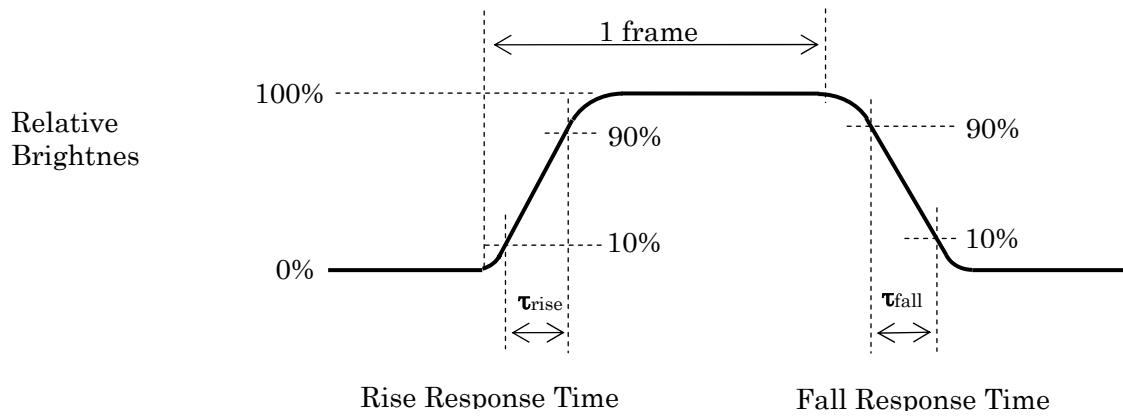

Figure 9-4 Definition of Response Time

Note 5) Contrast Ratio and Response Measurement System

Based on Figure 9-5.

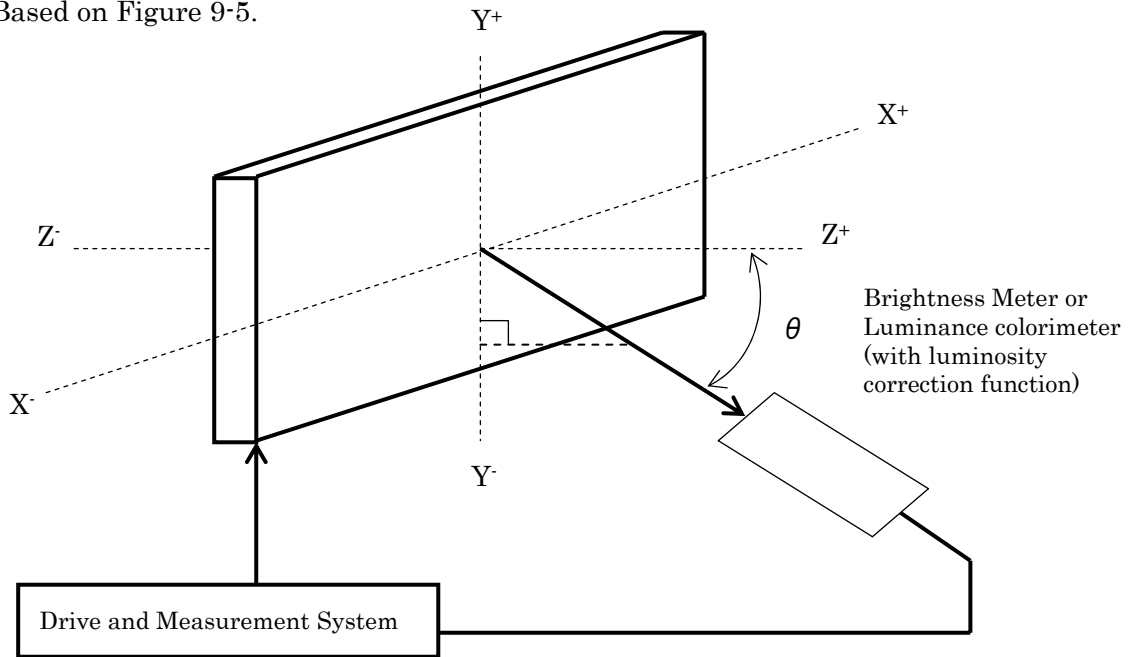

Figure 9-5 Contrast Ratio and Response Time Measurement System

DOCUMENT CONTROL SECTION

DATE

						TITLE		FLC51UXC8V-10L	
						DRAW. NO.		CUST.	
03 20040914						Change response time definition		Tech Bes LCD-00239	
EDIT	DATE	DESIG.	CHECK	APPR.	DESCRIPTION	FUJITSU DISPLAY TECHNOLOGIES CORPORATION		10/	F
DESIG.			CHECK		APPR.				

Note 6) Definition of Optimum Viewing Angle

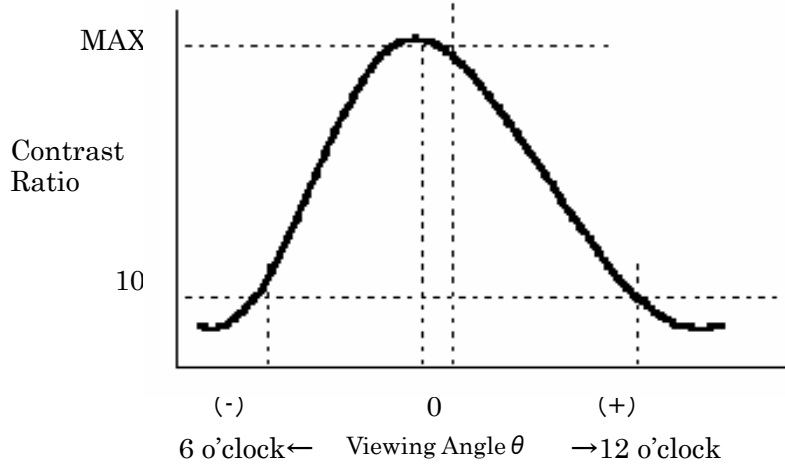

Figure 9-6 Definition of Viewing Angle

Note 7) Definition of Brightness Uniformity

Brightness uniformity is defined by the following formula.

Brightness (I1~I9) are measured at the following 9 points (①~⑨) on the display area that is shown in Figure 9-7.

$$\text{Brightness Uniformity } (\Delta L) = \frac{|\text{Min. In }|}{|\text{Max. In }|} \times 100 (\%) , n = 1 \text{ to } 9$$

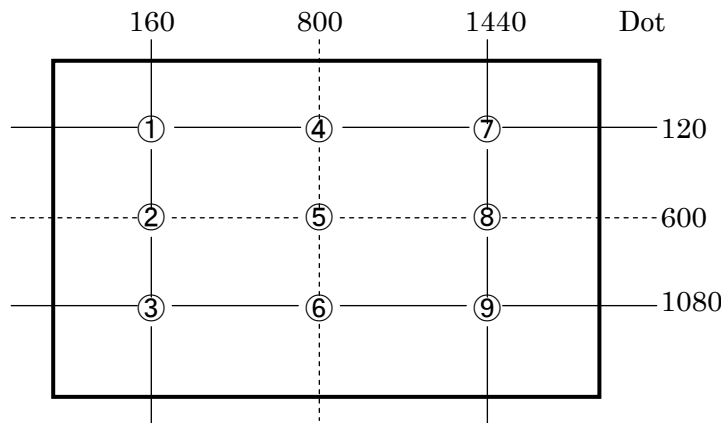

Note) Each measurement point (①~⑨) defines the center spot of view of Brightness Meter.  
The tolerance of measurement position is  $\pm 3\text{mm}$ .

Figure 9-7 Measurement Points

DOCUMENT CONTROL SECTION

						TITLE		FLC51UXC8V-10L	
						DRAW. NO.		Tech Bes LCD-00239	
								CUST.	
EDIT	DATE	DESIG.	CHECK	APPR.	DESCRIPTION				
DESIG.			CHECK		APPR.	FUJITSU DISPLAY TECHNOLOGIES CORPORATION		11 /	

# 10. INTERFACE SPECIFICATIONS

## 10-1 Signal descriptions

Table 10-1 shows the description and configuration of interface signals (CN1).

Table 10-1 Interface signals (CN1)

Pin No.	Symbol	I/O	Function
1	Vcc	—	+12V power supply
2	Vcc	—	+12V power supply
3	Vcc	—	+12V power supply
4	TST	—	Test pin *2
5	PD	I	LVDS Core Power Down
6	SEL LVDS	I	Select LVDS data order *1
7	GND	—	Ground
8	RxE3+	I	Positive differential input
9	RxE3-	I	Negative differential input
10	RxEC+	I	Positive differential input
11	RxEC-	I	Negative differential input
12	RxE2+	I	Positive differential input
13	RxE2-	I	Negative differential input
14	GND	—	Ground
15	RxE1+	I	Positive differential input
16	RxE1-	I	Negative differential input
17	GND	—	Ground
18	RxE0+	I	Positive differential input
19	RxE0-	I	Negative differential input
20	RxO3+	I	Positive differential input
21	RxO3-	I	Negative differential input
22	RxOC+	I	Positive differential input
23	RxOC-	I	Negative differential input
24	GND	—	Ground
25	RxO2+	I	Positive differential input
26	RxO2-	I	Negative differential input
27	RxO1+	I	Positive differential input
28	RxO1-	I	Negative differential input
29	RxO0+	I	Positive differential input
30	RxO0-	I	Negative differential input

Connector : FI-X30S-HF (Japan Aviation Electronics)  
 User's connector : FI-X30M (Japan Aviation Electronics)  
 FI-X30H  
 FI-X30C

\*1: 3.3V CMOS Signal input. (High or Low)

\*2: Keep open. (Internal test use only.)

\*3: When using a connector other than the recommended one, a defect in the initial stage or a problem concerning long term reliability may occur.

DOCUMENT CONTROL SECTION

DATE

						TITLE		FLC51UXC8V-10L	
						DRAW. NO.		Tech Bes LCD-00239	
								CUST.	
EDIT	DATE	DESIG.	CHECK	APPR.	DESCRIPTION		FUJITSU DISPLAY TECHNOLOGIES CORPORATION		12/
DESIG.			CHECK		APPR.				

10-2 LVDS Data Assignment

Table 10-2 shows the LVDS Data Assignment.

Table 10-2 LVDS Data Assignment

Input signal *1			Transmitter DS90CF383,C385		Interface connector			Receiver DS90CF386		LCD input (Sel LVDS)				
SEL LVDS	Low	High	pin	INPUT	System side	LCD module		pin	OUTPUT	Low	High			
						pin								
LVDS Odd	RO2	RO0	51	TxIN0	Tx OUT0+	2	RxO0+	27	RxOUT0	RO2	RO0			
	RO3	RO1	52	TxIN1				29	RxOUT1	RO3	RO1			
	RO4	RO2	54	TxIN2				30	RxOUT2	RO4	RO2			
	RO5	RO3	55	TxIN3				32	RxOUT3	RO5	RO3			
	RO6	RO4	56	TxIN4				33	RxOUT4	RO6	RO4			
	RO7	RO5	3	TxIN6	Tx OUT0-	1	RxO0-	35	RxOUT6	RO7	RO5			
	GO2	GO0	4	TxIN7				37	RxOUT7	GO2	GO0			
	GO3	GO1	6	TxIN8				38	RxOUT8	GO3	GO1			
	GO4	GO2	7	TxIN9				Tx OUT1+	4	RxO1+	39	RxOUT9	GO4	GO2
	GO5	GO3	11	TxIN12							43	RxOUT12	GO5	GO3
	GO6	GO4	12	TxIN13	45	RxOUT13	GO6				GO4			
	GO7	GO5	14	TxIN14	Tx OUT1-	3	RxO1-	46	RxOUT14	GO7	GO5			
	BO2	BO0	15	TxIN15				47	RxOUT15	BO2	BO0			
	BO3	BO1	19	TxIN18				51	RxOUT18	BO3	BO1			
	BO4	BO2	20	TxIN19	Tx OUT2+	6	RxO2+	53	RxOUT19	BO4	BO2			
	BO5	BO3	22	TxIN20				54	RxOUT20	BO5	BO3			
	BO6	BO4	23	TxIN21				55	RxOUT21	BO6	BO4			
	BO7	BO5	24	TxIN22				1	RxOUT22	BO7	BO5			
	RSVD	RSVD	27	TxIN24				Tx OUT2-	5	RxO2-	3	RxOUT24	Not use	Not use
	RSVD	RSVD	28	TxIN25	5	RxOUT25	Not use				Not use			
	ENAB	ENAB	30	TxIN26	6	RxOUT26	ENAB				ENAB			
	RO0	RO6	50	TxIN27	Tx OUT3+	11	RxO3+	7	RxOUT27	RO0	RO6			
	RO1	RO7	2	TxIN5				34	RxOUT5	RO1	RO7			
	GO0	GO6	8	TxIN10				41	RxOUT1	GO0	GO6			
	GO1	GO7	10	TxIN11				42	RxOUT11	GO1	GO7			
BO0	BO6	16	TxIN16	Tx OUT3-				10	RxO3-	49	RxOUT16	BO0	BO6	
BO1	BO7	18	TxIN17		50	RxOUT17	BO1			BO7				
RSVD	RSVD	25	TxIN23		2	RxOUT23	Not use			Not use				
DCLK			31	TxCLK IN	TxCLK OUT+	9	RxCLK IN+	26	RxCLK OUT	DCLK				
					TxCLK OUT-	8	RxCLK IN-							
LVDS Even	RE2	RE0	51	TxIN0	Tx OUT0+	13	RxEO+	27	RxOUT0	RE2	RE0			
	RE3	RE1	52	TxIN1				29	RxOUT1	RE3	RE1			
	RE4	RE2	54	TxIN2				30	RxOUT2	RE4	RE2			
	RE5	RE3	55	TxIN3				32	RxOUT3	RE5	RE3			
	RE6	RE4	56	TxIN4				Tx OUT0-	12	RxEO-	33	RxOUT4	RE6	RE4
	RE7	RE5	3	TxIN6	35	RxOUT6	RE7				RE5			
	GE2	GE0	4	TxIN7	37	RxOUT7	GE2				GE0			
	GE3	GE1	6	TxIN8	Tx OUT1+	16	RxE1+				38	RxOUT8	GE3	GE1
	GE4	GE2	7	TxIN9							39	RxOUT9	GE4	GE2
	GE5	GE3	11	TxIN12				43	RxOUT12	GE5	GE3			
	GE6	GE4	12	TxIN13	Tx OUT1-	15	RxE1-	45	RxOUT13	GE6	GE4			
	GE7	GE5	14	TxIN14				46	RxOUT14	GE7	GE5			
	BE2	BE0	15	TxIN15				47	RxOUT15	BE2	BE0			
	BE3	BE1	19	TxIN18	Tx OUT2+	19	RxE2+	51	RxOUT18	BE3	BE1			
	BE4	BE2	20	TxIN19				53	RxOUT19	BE4	BE2			
	BE5	BE3	22	TxIN20				54	RxOUT20	BE5	BE3			
	BE6	BE4	23	TxIN21				55	RxOUT21	BE6	BE4			
	BE7	BE5	24	TxIN22				1	RxOUT22	BE7	BE5			
	RSVD	RSVD	27	TxIN24	Tx OUT2-	18	RxE2-	3	RxOUT24	Not use	Not use			
	RSVD	RSVD	28	TxIN25				5	RxOUT25	Not use	Not use			
	RSVD	RSVD	30	TxIN26				6	RxOUT26	Not use	Not use			
	RE0	RE6	50	TxIN27	Tx OUT3+	23	RxE3+	7	RxOUT27	RE0	RE6			
	RE1	RE7	2	TxIN5				34	RxOUT5	RE1	RE7			
	GE0	GE6	8	TxIN10				41	RxOUT10	GE0	GE6			
	GE1	GE7	10	TxIN11				42	RxOUT11	GE1	GE7			
BE0	BE6	16	TxIN16	Tx OUT3-				22	RxE3-	49	RxOUT16	BE0	BE6	
BE1	BE7	18	TxIN17		50	RxOUT17	BE1			BE7				
RSVD	RSVD	25	TxIN23		2	RxOUT23	Not use			Not use				
DCLK			31	TxCLK IN	TxCLK OUT+	21	RxCLK IN+	26	RxCLK OUT	Not use				
					TxCLK OUT-	20	RxCLK IN-							

\*1 •RSVD (reserved) pin on a transmitter should be connected with Ground.

•Input odd or even data depending on the display position of the LCD module.

DOCUMENT CONTROL SECTION

DATE

						TITLE FLC51UXC8V-10L					
						DRAW. NO. Tech Bes LCD-00239					CUST.
EDIT	DATE	DESIG.	CHECK	APPR.	DESCRIPTION FUJITSU DISPLAY TECHNOLOGIES CORPORATION						13/
DESIG.			CHECK			APPR.					

10-3 Color Data Assignment

Table 10-3 shows the Color Data Assignment.

Table 10-3 Color Data Assignment

Color		R Input data								G Input data								B Input data							
	Odd	R7	R6	R5	R4	R3	R2	R1	R0	G7	G6	G5	G4	G3	G2	G1	G0	B7	B6	B5	B4	B3	B2	B1	B0
	Even	R7	R6	R5	R4	R3	R2	R1	R0	G7	G6	G5	G4	G3	G2	G1	G0	B7	B6	B5	B4	B3	B2	B1	B0
Basic Color	Black	0	0	0	0	0	0	0	0	0	0	0	0	0	0	0	0	0	0	0	0	0	0	0	0
	Blue	0	0	0	0	0	0	0	0	0	0	0	0	0	0	0	0	1	1	1	1	1	1	1	1
	Green	0	0	0	0	0	0	0	0	1	1	1	1	1	1	1	1	0	0	0	0	0	0	0	0
	Cyan	0	0	0	0	0	0	0	0	1	1	1	1	1	1	1	1	1	1	1	1	1	1	1	1
	Red	1	1	1	1	1	1	1	1	0	0	0	0	0	0	0	0	0	0	0	0	0	0	0	0
	Magenta	1	1	1	1	1	1	1	1	0	0	0	0	0	0	0	0	1	1	1	1	1	1	1	1
	Yellow	1	1	1	1	1	1	1	1	1	1	1	1	1	1	1	1	0	0	0	0	0	0	0	0
	White	1	1	1	1	1	1	1	1	1	1	1	1	1	1	1	1	1	1	1	1	1	1	1	1
Red	Black	0	0	0	0	0	0	0	0	0	0	0	0	0	0	0	0	0	0	0	0	0	0	0	0
	↑	1	0	0	0	0	0	0	0	0	0	0	0	0	0	0	0	0	0	0	0	0	0	0	0
	↑	:	:	:	:	:	:	:	:	:	:	:	:	:	:	:	:	:	:	:	:	:	:	:	
	↓	:	:	:	:	:	:	:	:	:	:	:	:	:	:	:	:	:	:	:	:	:	:	:	
	Brighter	253	1	1	1	1	1	1	0	0	0	0	0	0	0	0	0	0	0	0	0	0	0	0	0
	↓	254	1	1	1	1	1	1	0	0	0	0	0	0	0	0	0	0	0	0	0	0	0	0	0
	Red	255	1	1	1	1	1	1	1	0	0	0	0	0	0	0	0	0	0	0	0	0	0	0	0
Green	Black	0	0	0	0	0	0	0	0	0	0	0	0	0	0	0	0	0	0	0	0	0	0	0	0
	↑	1	0	0	0	0	0	0	0	0	0	0	0	0	0	0	1	0	0	0	0	0	0	0	0
	↑	:	:	:	:	:	:	:	:	:	:	:	:	:	:	:	:	:	:	:	:	:	:	:	
	↓	:	:	:	:	:	:	:	:	:	:	:	:	:	:	:	:	:	:	:	:	:	:	:	
	Brighter	253	0	0	0	0	0	0	0	1	1	1	1	1	1	0	1	0	0	0	0	0	0	0	0
	↓	254	0	0	0	0	0	0	0	1	1	1	1	1	1	0	0	0	0	0	0	0	0	0	
	Green	255	0	0	0	0	0	0	0	1	1	1	1	1	1	1	0	0	0	0	0	0	0	0	
Blue	Black	0	0	0	0	0	0	0	0	0	0	0	0	0	0	0	0	0	0	0	0	0	0	0	0
	↑	1	0	0	0	0	0	0	0	0	0	0	0	0	0	0	0	0	0	0	0	0	0	0	1
	↑	:	:	:	:	:	:	:	:	:	:	:	:	:	:	:	:	:	:	:	:	:	:	:	
	↓	:	:	:	:	:	:	:	:	:	:	:	:	:	:	:	:	:	:	:	:	:	:	:	
	Brighter	253	0	0	0	0	0	0	0	0	0	0	0	0	0	0	0	1	1	1	1	1	1	0	1
	↓	254	0	0	0	0	0	0	0	0	0	0	0	0	0	0	0	1	1	1	1	1	1	1	0
	Blue	255	0	0	0	0	0	0	0	0	0	0	0	0	0	0	0	1	1	1	1	1	1	1	1

Note.1) Definition of gray scale:Color (n)···"n" indicates gray scale level.

Larger number means brighter level.

Note.2) Data; 1:High, 0:Low

Note 3) Color data consist of 8 bit red, green and blue data of odd and even number pixel data. Total data number is 48 signals. This module is able to display 16,777,216 colors because each red, green and blue data is controlled independently.

DOCUMENT CONTROL SECTION

DATE

						TITLE		FLC51UXC8V-10L			
						DRAW. NO.			CUST.		
						Tech Bes LCD-00239					
EDIT	DATE	DESIG.	CHECK	APPR.	DESCRIPTION					FUJITSU DISPLAY TECHNOLOGIES CORPORATION	14/
DESIG.			CHECK		APPR.						

**10-4 Input Signal Timing**

Table 10-4 and Figure 10-1 shows the Input Signal Timing at LVDS transmitter.

**Table 10-4 Timing Characteristics** (Ta=0~45°C, Vcc=12±0.5V)

Item		Symbol	Min.	Typ.	Max.	Unit	Remark
DCLK signal (Clock)	Period	Tc	11.765	12.345	20.000	ns	
	Frequency	1/Tc	50.000	81.000	85.000	MHz	
	Duty	Tch/Tc	45	50	55	%	
	High time	TclkH	3.5	—	—	ns	
	Low time	TclkL	3.5	—	—	ns	
DCLK-Data Timing	Setup time	Tset	3	—	—	ns	
	Hold time	Thold	2	—	—	ns	
ENAB signal	Horizontal Period	Th	865*1	1080	1130*1	DCLK	
	Hor. Period	Th	13.0	13.3	14.65	μs	
	Hor. Display period	Thd	800	800	800	DCLK	*2
	Vertical Period	Tv	1207*1	1250	1280*1	Hz	
	Ver. Frequency	1/Tv	50	60	62	Hz	
		Tvd	1200	1200	1200	Hz	
	Ver. Display period	Th				Th	
Data-ENAB timing	Tdn	—	0	—	DCLK	*3	

\*1) • horizontal display position is specified by the rise of ENAB.

The data latched at falling edge of DCLK after rise of ENAB is displayed at the left edge of the display area.

• Vertical display position is specified by the rise of ENAB after low level continuation over 5500 DCLK.

The data latched at the rise of ENAB is displayed at the top line of the display area.

\*2) • If the “High” level period of ENAB is less than 800 DCLK, black color is displayed at the rest of the display area.

\*3) • If ENAB does not synchronize with the effective display data, the display position does not fit to the display area.

DATE DOCUMENT CONTROL SECTION

						TITLE		FLC51UXC8V-10L	
						DRAW. NO.		Tech Bes LCD-00239	
						CUST.			
EDIT	DATE	DESIG.	CHECK	APPR.	DESCRIPTION		FUJITSU DISPLAY TECHNOLOGIES CORPORATION		15/
DESIG.			CHECK		APPR.				

A

A

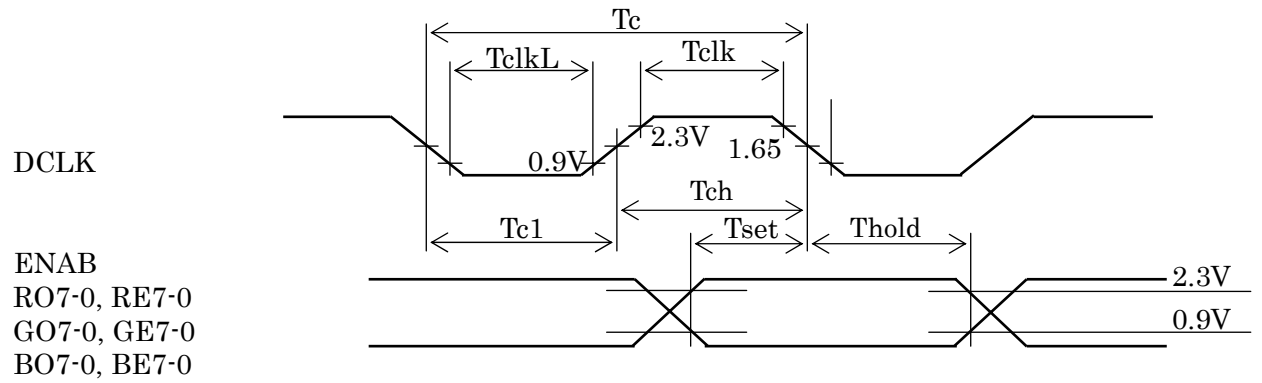

B

B

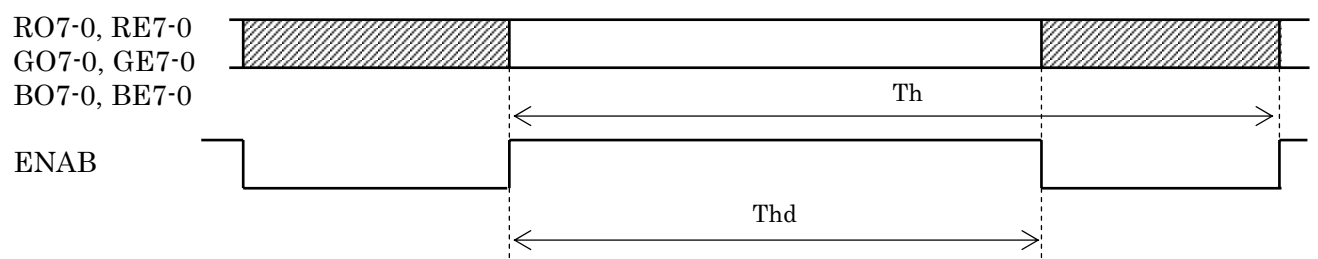

C

C

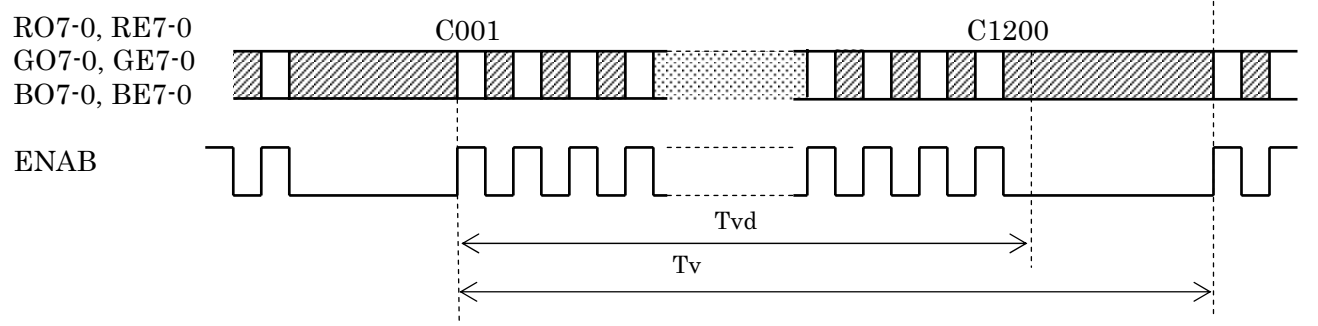

D

D

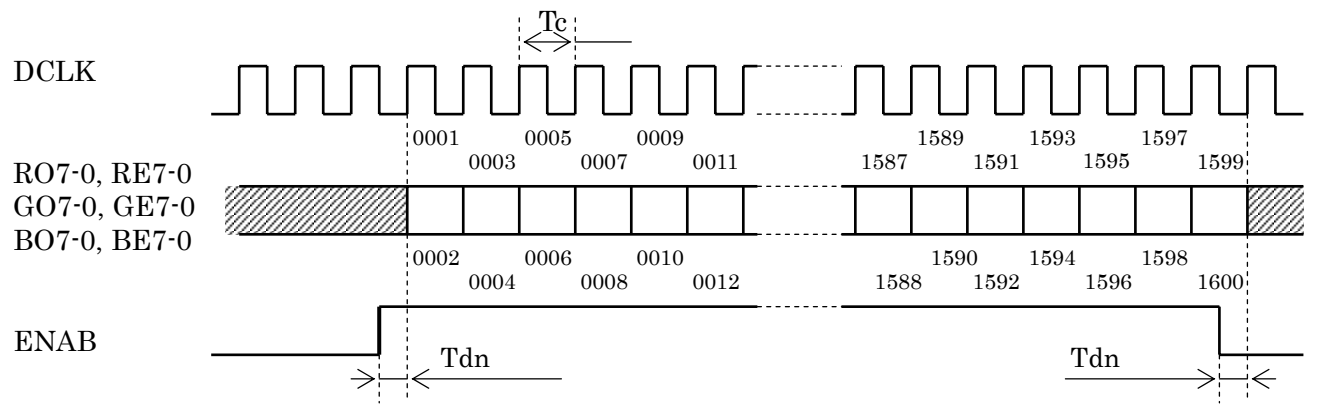

Figure 10-1 Input Signal Timing Chart

DOCUMENT CONTROL SECTION

DATE

E

F

						TITLE		FLC51UXC8V-10L	
						DRAW. NO.			CUST.
						Tech Bes LCD-00239			
EDIT	DATE	DESIG.	CHECK	APPR.	DESCRIPTION		FUJITSU DISPLAY TECHNOLOGIES CORPORATION		16/
DESIG.			CHECK		APPR.				

10-4 Correspondence between Data and Display Position

Figure 10-2 shows the Correspondence between Data and Display Position.

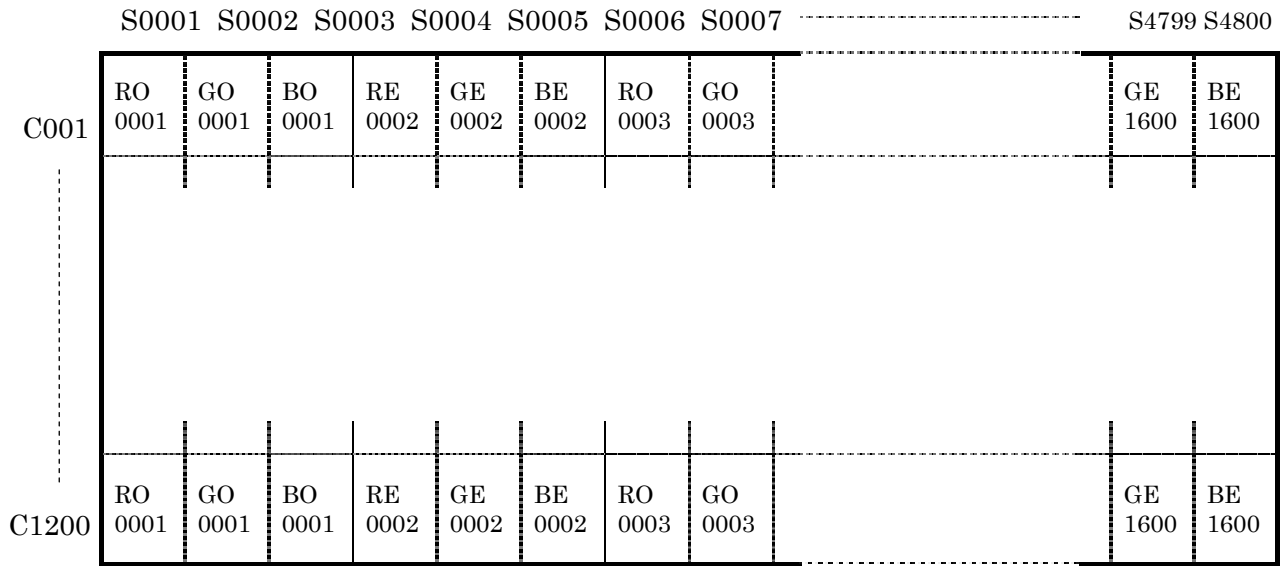

Figure 10-2 Correspondence Data and Display Position

10-5 Power Supply Sequence

The sequence of input signals and On/Off of the power supply of this LCD module should be in the specification shown in Figure 10-3 to prevent latch-up of the driver ICs and DC driving of the LCD panel.

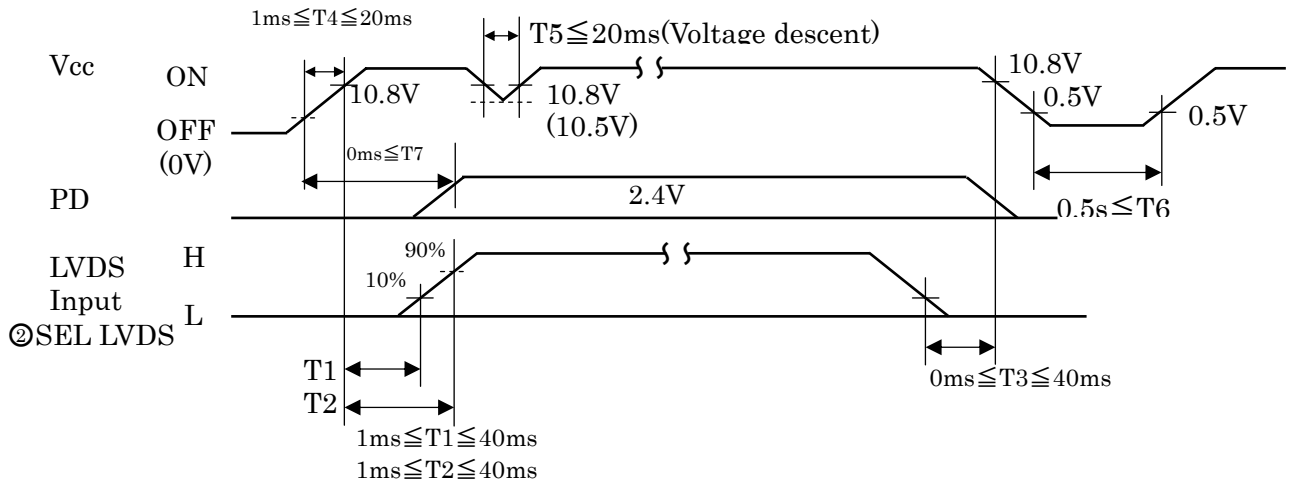

Figure 10-3 Power Supply Sequence (Logic)

Note) If Power Supply Sequence not followed, the CMOS-IC may cause a latch-up, or DC voltage may be applied to the liquid crystal, which cause a failure or serious deterioration in display quality.

DOCUMENT CONTROL SECTION

						TITLE FLC51UXC8V-10L	
						DRAW. NO. Tech Bes LCD-00239	
02 20040120						CUST.	
Change Figure10-3						FUJITSU DISPLAY TECHNOLOGIES CORPORATION	
EDIT	DATE	DESIG.	CHECK	APPR.	DESCRIPTION	17/	
DESIG.			CHECK		APPR.		

# 11. BACK-LIGHT SPECIFICATION

## 11-1 Pin configuration for Back-light

Table 11-1 shows the description and Pin assignment of the connectors (CN-A to D) for the Back-light of this LCD module.

Table 11-1 Pin Assignment of CN-A to CN-D

No.	Pin No.	Symbol	Function	Cable Color
CN-A	1	V <sub>H1</sub>	Power supply (High voltage)	Pink
	2	V <sub>H2</sub>	Power supply (High voltage)	Orange
	3	-	NC	
	4	V <sub>L1</sub>	Power supply (Low voltage)	Blue
	5	V <sub>L2</sub>	Power supply (Low voltage)	Gray
CN-B	1	V <sub>H3</sub>	Power supply (High voltage)	Red
	2	V <sub>L3</sub>	Power supply (Low voltage)	White
CN-C	1	V <sub>H4</sub>	Power supply (High voltage)	Pink
	2	V <sub>H5</sub>	Power supply (High voltage)	Orange
	3	-	NC	
	4	V <sub>L4</sub>	Power supply (Low voltage)	Blue
	5	V <sub>L5</sub>	Power supply (Low voltage)	Gray
CN-D	1	V <sub>H6</sub>	Power supply (High voltage)	Red
	2	V <sub>L6</sub>	Power supply (Low voltage)	White

Connector : Housing(CN-A, CN-C):BHR-05VS-1  
(CN-B, CN-D):BHSR-02VS-1  
Contact : SBH-001T-P0.5  
SBHS-002T-P0.5

User's Connector : Post with base: SM04(9-E2)B-BHS-1  
SM02B-BHSS-1-TB

Supplier : Japan Solder less Terminal manufacturing Company LTD. (J.S.T.)

## 11-2 CCFL

Supplier: SANKEN ELECTRONICS Co.LTD. Part No.: SS26E4175E8550C2882710S

## 11-3 Life

The life of the back-light is a minimum of 50,000 hours at the following conditions.

### (1) Working conditions

- ①Ambient temperature: 25 ± 5°C
- ②Tube current (I<sub>L</sub>) : (6mA or less)

### (2) Definition of life

- ①Brightness becomes 50% or less than the minimum brightness value shown in Table 9-1.
- ②Flashing.

## 11-4 Lamp assembly set (for replacement)

Lamp assembly set (with charge) is prepared for replacing old lamp to new one.  
This set consists of an upper lamp assembly and a lower lamp assembly.  
Type number: T.B.D.

DATE DOCUMENT CONTROL SECTION

						TITLE FLC51UXC8V-10L	
						DRAW. NO. Tech Bes LCD-00239	
						CUST.	
EDIT	DATE	DESIG.	CHECK	APPR.	DESCRIPTION	FUJITSU DISPLAY TECHNOLOGIES CORPORATION	
DESIG.			CHECK		APPR.	18/	

**12. APPEARANCE SPECIFICATIONS**

12-1 Appearance

12-1-1 Appearance specification

No.	Item	Judgment method and standard		
1	Bright spot (high and Low)	$\leq 6$ dots		(Note 1)
2	Bright spot connection (high and low)	$\leq 2$ pair		(Note 1)
3	Total of bright spot	$\leq 6$ dots		
4	Dark spot	$\leq 10$ dots		(Note 2)
5	Dark spot connection	$\leq 4$ pairs		(Note 2)
6	Total of dark spot	$\leq 10$ dots		(Note 2)
7	Total of dot defect (bright and dark)	$\leq 10$ dots		
8	Distance of bright spot	high-hgh	$\geq 15$ mm	
		others	$\geq 5$ mm	
9	Distance of dark spot	$\geq 5$ mm		
10	Scratch on polarizer, line shape	$W \leq 0.03$	—————	Ignore
			$L \leq 6$	Ignore
		$0.03 < W \leq 0.05$	$6 < L \leq 12$	$\leq 7$
			$12 < L$	0
		$0.05 < W \leq 0.10$	$L \leq 0.6$	Ignore
			$0.6 < L \leq 5$	$\leq 5$
$5 < L$	0			
$0.10 < W$	—————	0		
11	Dent on polarizer, dot shape	$D \leq 0.3$		Ignore
		$0.3 < D \leq 0.4$		$\leq 9$
		$0.4 < D$		0
12	Bubble in polarizer	$D \leq 0.3$		Ignore
		$0.3 < D \leq 0.5$		$\leq 4$
		$0.5 < D$		0
13	Black white spot (Foreign circular matter)	$D \leq 0.15$		Ignore
		$0.15 < D \leq 0.5$		$\leq 5$
		$0.5 < D$		0
14	Light leakage by foreign articles	$D \leq 0.3$		Ignore
		$0.3 < D \leq 0.6$		$\leq 5$
		$0.6 < D$		0
15	Lints, black/white line	$W \leq 0.03$	—————	Ignore
			$L \leq 6$	Ignore
		$0.03 < W \leq 0.05$	$6 < L \leq 12$	$\leq 6$
			$12 < L$	0
		$0.05 < W \leq 0.10$	$L \leq 0.6$	Ignore
			$0.6 < L \leq 5$	$\leq 3$
$5 < L$	0			
$0.10 < W$	$(W+L)/2=D$	Conform to No.13		
16	Mura	Invisible under 6% ND filter from center of display. (Display pattern: Black, White, 50%gray)		

D: Average diameter [mm], W: Width [mm], L: Length [mm], S=(bright spot size)/(dot size)

DOCUMENT CONTROL SECTION

DATE

						TITLE		FLC51UXC8V-10L	
						DRAW. NO.		Tech Bes LCD-00239	
						CUST.			
EDIT	DATE	DESIG.	CHECK	APPR.	DESCRIPTION		FUJITSU DISPLAY TECHNOLOGIES CORPORATION		19 /
DESIG.			CHECK		APPR.				

12-1-2 Light leakage outside the active area.

The light leakage that occurs minimum of 2.0mm outside the peripheral of the active area is overlooked.

A leakage of light may occur between the BM section and the bezel at the peripheral of the active area.

12-2 Dot defects (Bright spots, Dark spots)

12-2-1 Zone

- Inside display dot area (408.0 X 306.0mm)
- Display dot area means active area.
- One pixel consists of 3 dots (red, green and blue).
- Foreign particle and scratch unharmed to display image, such as the foreign particle under polarizer film but outside of the display area and scratch on metal bezel, backlight module or polarizer film out of the display area, etc., are not counted.

12-2-2 Bright spots

(1) Bright spots by the defect of TFT.

- Visible under bias of 2% ND filter .....High bright spot R·G
- Visible under 5% but invisible under 2% ND filter .....Low bright spot R·G·B
- Invisible under bias of 5% ND filter.....Not counted

(2) Bright spots by the light passing through tears, breaks, etc in color filter.

- Exceed size of a half dot.....High bright spot
- A half dot or less .....Not counted

(3) Bright spots by the light passing through tears, breaks, etc in chromium mask.

- Exceed 50µm .....High bright spot
- 50µm or less .....Not counted

12-2-3 Test condition

· Inspector must observe the LCD screen from the normal direction under the illumination by a single 20W fluorescent lamp. The distance between the LCD screen and the inspector should be a height of 50cm above the worktable.

The vertical illuminance is 300 to 600lux (reference value).

- Bright spot should be counted under entire black screen.
- Dark spot should be counted under entire white screen.
- Input signal timing should be typical value.

(Note1) Please do not mistake a single bright spot for a bright spot connection due to Cs(supplemental capacitance) line at the center of each dot.

(Note2) If a pixel is dark partially, it connects into the number of dark spots in accordance with following rule.

- (a)  $A < 1/3$  : Not count. Only one of 4 dark connection is allowed.
- (b)  $1/3 \leq A < 2/3$  : Considered as 0.5 dot.
- (c)  $2/3 \leq A$  : Considered as 1 dot.

(A=Dark spot size/dot size)

DOCUMENT CONTROL SECTION

DATE

						TITLE		FLC51UXC8V-10L	
						DRAW. NO.		CUST.	
						Tech Bes LCD-00239			
EDIT	DATE	DESIG.	CHECK	APPR.	DESCRIPTION		FUJITSU DISPLAY TECHNOLOGIES CORPORATION		20 /
	DESIG.		CHECK		APPR.				

### 13. ENVIRONMENTAL SPECIFICATIONS

Table 13-1 show the environmental specifications.

Table 13-1 Environmental specifications

Item	Condition		Remark
Temperature	Operation	0~45°C	Temperature on surface of LCD panel should be under 54°C.
	Storage	-20~60°C	
Humidity	Operation	20~85%RH	Maximum wet-bulb temperature should not exceed 29°C. No condensation.
	Storage	5~85%RH	
Vibration	Non-operation	10~500Hz, 1octave/20minute, 2G, 1.5mm max, 1hour each X, Y and Z directions	For single module without package.
Shock	Non-operation	30G, 6ms, 1time each ±X, ±Y and ±Z directions.	

NOTE: Table 13-2 and Figure 13-1 show the shock resistance standard when module is packaged.

Table 13-2 Shock resistance standard when module is packaged

Dropping location	Dropping height	Count
A~J	60cm	1 time

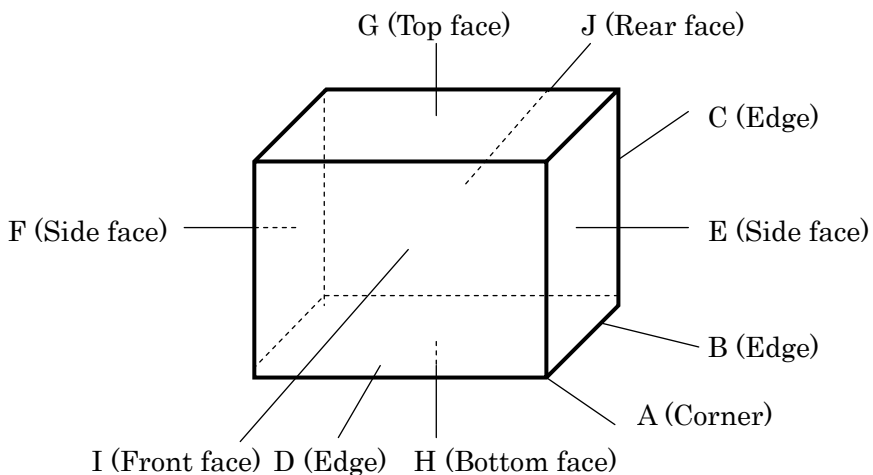

Figure 13-1 Direction to apply shock to package

DOCUMENT CONTROL SECTION

						TITLE		FLC51UXC8V-10L	
						DRAW. NO.		CUST.	
						Tech Bes LCD-00239			
EDIT	DATE	DESIG.	CHECK	APPR.	DESCRIPTION		FUJITSU DISPLAY TECHNOLOGIES CORPORATION		21 /

# 14. INDICATIONS

This module has the following indications.

- (1) Product name : **LCD unit.** (See Figure 14-2)
- (2) Model Number : **FLC51UXC8V-10L** (See Figure 14-2)
- (3) Product Drawing Number : **NA19025-C453** (See Figure 14-2)
- (4) Manufacturing Number : **3 9 0 0 0 1**

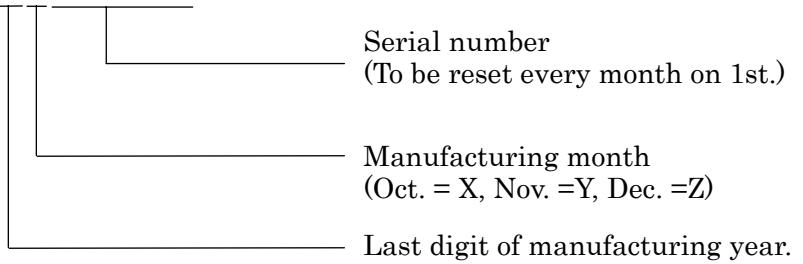

- (5) Version number ② : **03C** (Example)
  - 1st 2 digits "01" means operational version.
  - 3rd alphabet means functional version.

(6) Manufacturer Country Name : **MADE IN JAPAN**

(7) Company Name : **FUJITSU DISPLAY TECHNOLOGIES CORPORATION**

(8) Disposal method of cold-cathode tubes. (See Figure 14-1)

(9) Caution when changing cold-cathode tubes. (See Figure 14-1)

・ WHEN CHANGING COLD CATHODE FLUORESCENT LAMPS, FOLLOW OPERATING SPECIFICATIONS. ESPECIALLY BE CAREFUL ABOUT THE LAMP'S SIDE-EDGE.  
 ・ 蛍光管の交換は作業仕様書に従って行って下さい。特に蛍光管ホルダ側面のエッジに気をつけて下さい。

・ THIS TFT COLOR LCD CONTAINS COLD CATHODE FLUORESCENT LAMPS. PLEASE FOLLOW LOCAL ORDINANCES OR REGULATIONS FOR ITS DISPOSAL.  
 ・ 当該液晶ディスプレイユニットには蛍光管が組み込まれていますので、地方自治体の条例または規則に従って廃棄して下さい。

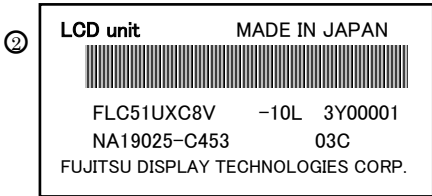

Figure 14-1

Figure 14-2

# 15. PACKAGING

## 15-1 Packing specifications

- (1) 4LCD modules/1package.
- (2) Weight: approximately 17kg/1package.
- (3) Outline dimensions: 576mm(W)x316mm(D)x508mm(H)

## 15-2 Packing method

Figure 15-1,2 shows the packing method.

DOCUMENT CONTROL SECTION

						TITLE		FLC51UXC8V-10L	
						DRAW. NO.		CUST.	
						Tech Bes LCD-00239			
02	20040120					Change Version number, Fig.14-2			
EDIT	DATE	DESIG.	CHECK	APPR.	DESCRIPTION		FUJITSU DISPLAY TECHNOLOGIES CORPORATION		22 /
DESIG.			CHECK		APPR.				

A

B

C

D

A

B

C

D

E

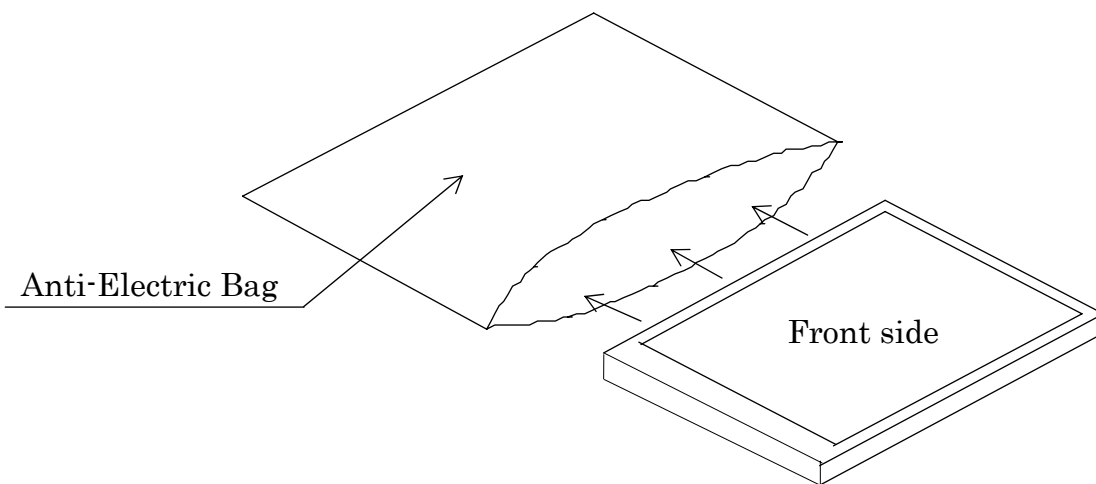
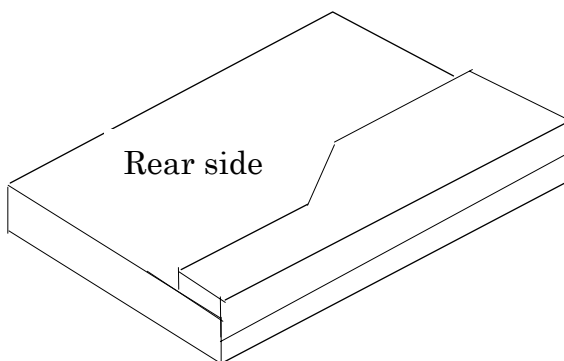
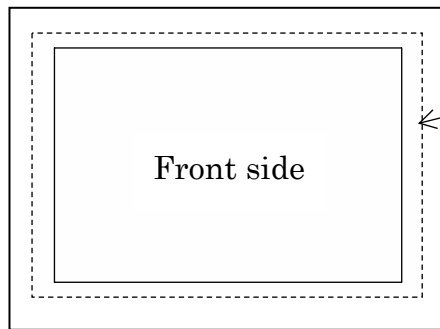
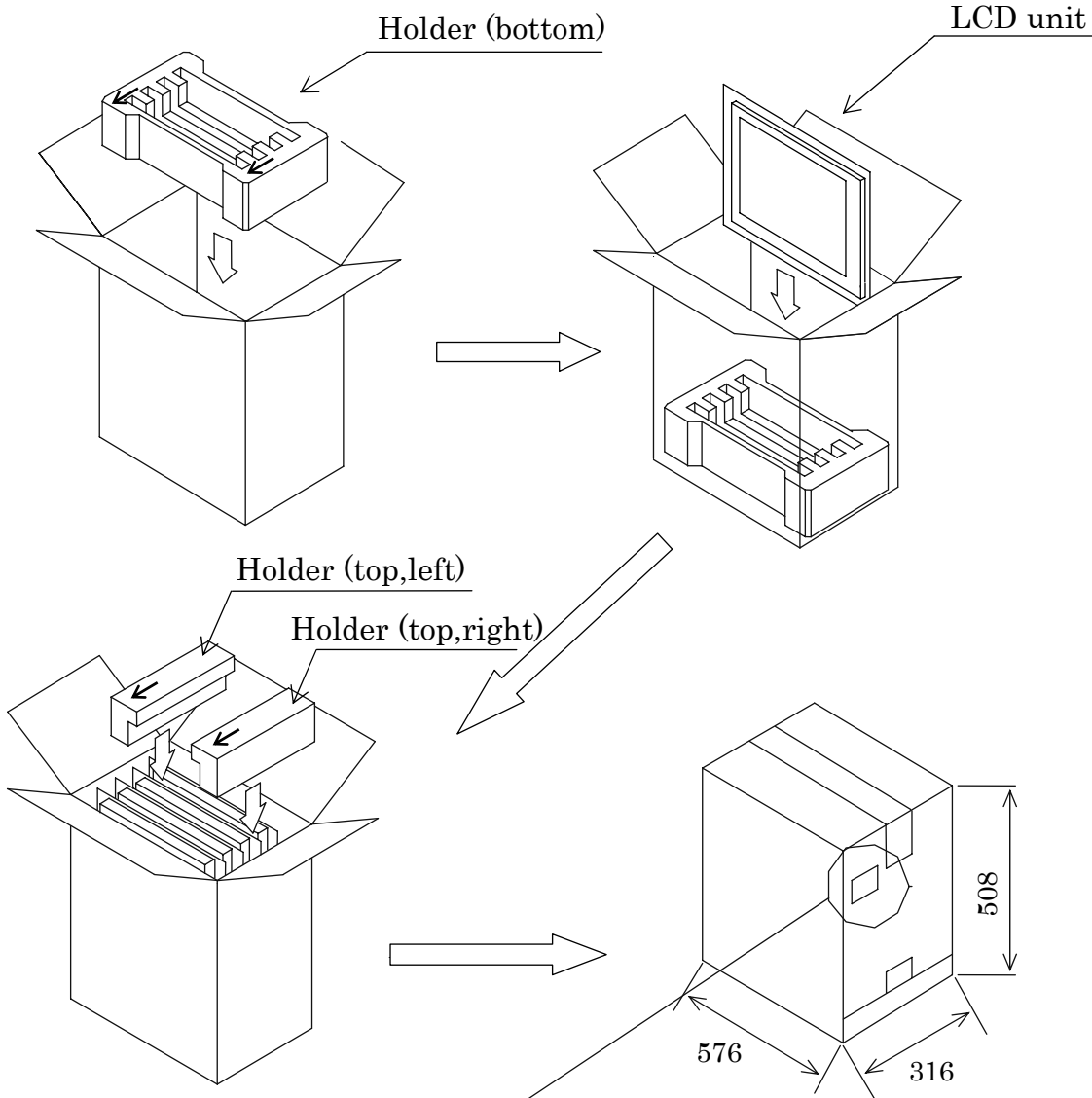

Fig.15-2 (a) Packaging Method

DOCUMENT CONTROL SECTION	
DATE	

						TITLE	FLC51UXC8V-10L	
						DRAW. NO.	Tech Bes LCD-00239	
							CUST.	
EDIT	DATE	DESIG.	CHECK	APPR.		FUJITSU DISPLAY TECHNOLOGIES CORPORATION		23 /
	DESIG.		CHECK		APPR.			



Label (example)

型 格 (TYPE)	FLC51UXC8V-10L	数 量 (QTY.)	4
図 番 (DRWG. NO.)	NA19025-C453	版 数 (REV. NO.)	03C
Bar code	2900001	Bar code	
	2900002		
	2900003		
	2900004		
Bar code			
MADE IN JAPAN			

- Taping  
 Top : H or I method  
 Bottom : H or I method
- Top and bottom holders should be anti-electrostatic type.

Fig.15-2 (b) Packaging Method

DOCUMENT CONTROL SECTION
DATE

					TITLE FLC51UXC8V-10L	
					DRAW. NO. Tech Bes LCD-00239	
					CUST.	
EDIT	DATE	DESIG.	CHECK	APPR.	DESCRIPTION FUJITSU DISPLAY TECHNOLOGIES CORPORATION	
DESIG.			CHECK	APPR.	24 /	

1

2

3

4

A

A

B

B

C

C

D

D

E

F

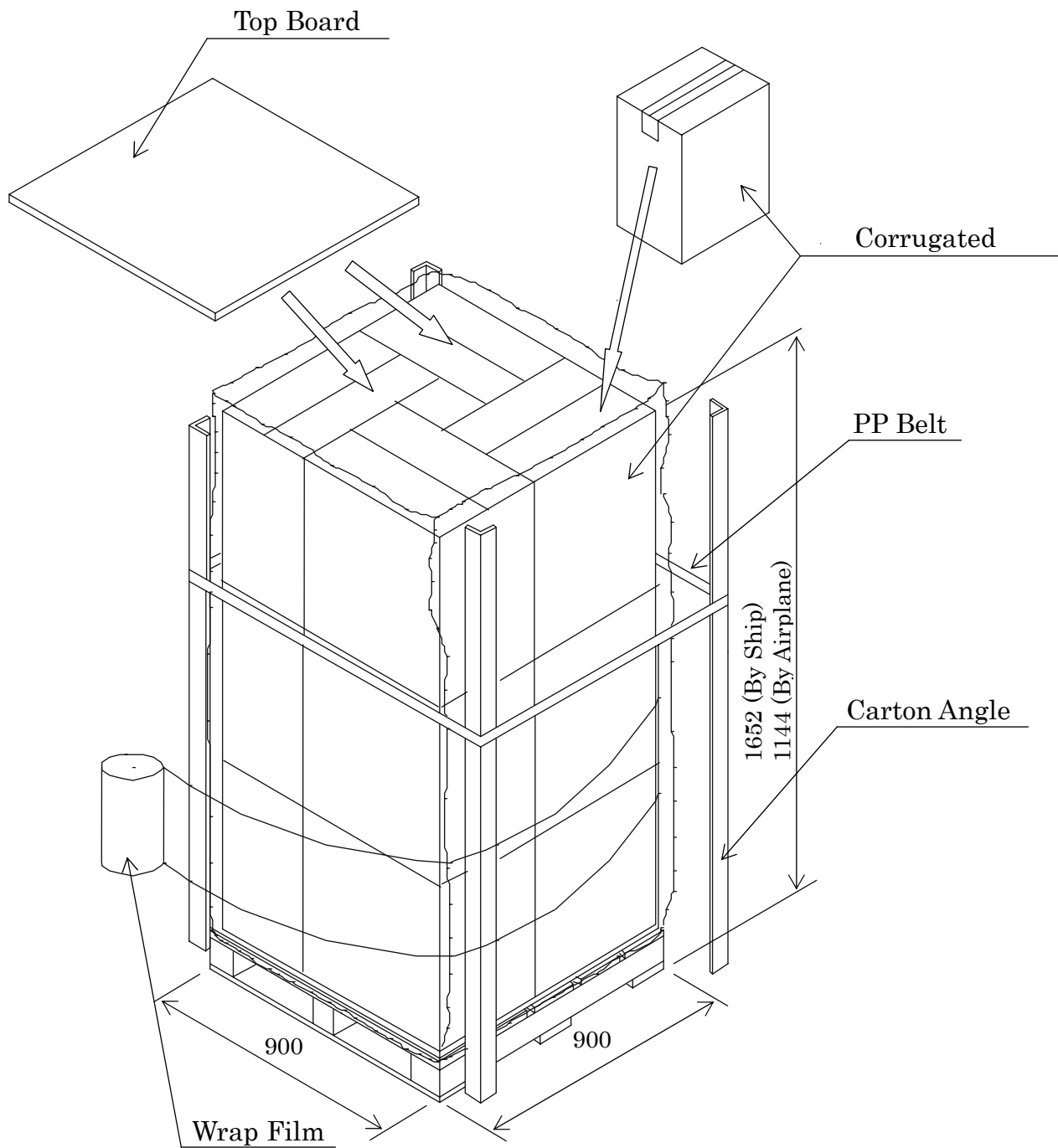

Wrap Film  
 Up and Down : 3 times wrap  
 Middle : 2 times wrap

Note:1) 4 boxes × 3 layers (maximum 12 boxes) : by ship  
 4 boxes × 2 layers (maximum 8 boxes) : by airplane  
 Note:2) This drawing shows marine transportation specification.

**Fig.15-2 (c) Packaging Method**

DOCUMENT CONTROL SECTION
DATE

						TITLE FLC51UXC8V-10L	
						DRAW. NO. Tech Bes LCD-00239	
						CUST.	
EDIT	DATE	DESIG.	CHECK	APPR.	DESCRIPTION FUJITSU DISPLAY TECHNOLOGIES CORPORATION		
DESIG.			CHECK	APPR.			25 /

1

A

A

Cushioning material

Corrugated carton (A)  
with LCD modules

B

B

602  
(580)

Corrugated fiberboard shipping container (B)

446  
(430)

646  
(630)

C

C

Note 1) The carton (A) should be placed in the middle of the container (B) with enough cushioning materials.

Note2) The figures in ( ) show inside measurements of the container (B).

Figure.15-2 (d) Packing method

D

D

DOCUMENT CONTROL SECTION

DATE

E

F

						TITLE FLC51UXC8V-10L	
						DRAW. NO. Tech Bes LCD-00239	
						CUST.	
EDIT	DATE	DESIG.	CHECK	APPR.	DESCRIPTION		
DESIG.			CHECK		FUJITSU DISPLAY TECHNOLOGIES CORPORATION		
						26 /	

### 16.WARRANTY

The warranty period is one year after shipping. Products which fail during this period are repaired or replaced without charge, unless the failure is caused by user.

### 17.PRECAUTIONS

Adhere to the following precautions to use this LCD module properly.

#### (1) Handling of LCD panel

##### ① Do not apply any strong mechanical shock to the LCD panel.

Since the LCD panel is made of glass, excessive shock may damage the panel or cause a malfunction.

##### ② Do not press hard on the LCD panel surface.

In the LCD panel, the gap between two glass plates is kept perfectly even to maintain display properties and reliability. The hard pressure on the LCD panel may cause the following problems. If the pressure is over 2kg/cm<sup>2</sup>, the problem don't return to normal Condition.

- ① Ununiformity of color
- ② Disorder of orientation of liquid crystal

Problem ① returns to normal condition after a while. Problem ② returns to normal condition by turning the power off and turning on again.

However these operations should be avoided to insure reliability.

##### ③ Do not scratch the polarizer film on the LCD panel surface.

- Do not press or rub the display surface with a hard tool, tweezers, etc.
- For handling, use cotton or conductive gloves so that the display surface is not soiled.
- If dust or dirt soils the display surface, clean it as follows with a soft cloth (deerskin, etc.)

[Dust] Wipe off with a soft cloth. (do not rub.)

[Dirt ] Apply clear water to a soft cloth and squeeze hard out of water drops, then lightly wipe off the specified parts. Only if the dirt is hardly wiped off, use isopropyl alcohol or ethanol.

Be careful not to splash the water or the solvents on the edge of polarizer and in the LCD unit.

The polarizer possibly exfoliates due to the solvent and water penetrated between the polarizer and the LCD panel.

Do not use unspecified solvent such as ketone (acetone, etc.) and aromatics (xylene, toluene, etc.)

(Caution) Be careful not to allow the water or solvent to enter the module.

- If saliva or water drops are left for a long period of time, the part may become deformed or discolored.

Wipe off immediately in the same way as for dirt.

- Do not allow oil to adhere to the module since excessive oil is hard to clean.

DOCUMENT CONTROL SECTION

DATE

						TITLE		FLC51UXC8V-10L		
						DRAW. NO.			CUST.	
						Tech Bes LCD-00239				
EDIT	DATE	DESIG.	CHECK	APPR.	DESCRIPTION				FUJITSU DISPLAY TECHNOLOGIES CORPORATION	27 /

**④ Do not place or contact objects on the display surface for a long period of time.**

This may make some parts of the LCD module distorted and the quality of display may deteriorate.

A

A

**(2) Handling of LCD module**

**① Do not pull the cold-cathode tube cable strongly.**

If the cable is pulled with the strength of 2kg or more, the cable may be damaged or may lose reliability.

**② Assemble the module into user's system in a dust free environment.**

Conductive foreign matter adheres to the module may cause failures.

**③ Take anti-electrostatic measures for assembling the module.**

Since the LCD module contains CMOS-ICs, the following points should be observed.

- For assembling the module, operator should be grounded and wear cotton or conductive gloves.
- Floor of work area and work table to assemble the LCD module should be covered with electrostatic shielding in order to discharge static electricity via an earth wire.
- If necessary, ground operation tools (soldering iron, radio pliers, tweezers, etc.).
- Do not take the module out of the conductive bag until the module is assembled.
- Do not assemble the module under low humidity (50%RH or less).

B

B

**④ Do not pull the connecting cable on the rear face of the LCD module strongly.**

**⑤ Do not disassemble or remodel the LCD module.**

Disassembly or remodeling of the LCD module may result in malfunctions or deterioration of the display quality and reliability.

C

C

**(3) Precautions in regards of operating the LCD module**

**① Adhere to the specified power supply sequence.**

If not followed, the CMOS-IC may cause a latch-up, or DC voltage may be applied to the liquid crystal, which cause a failure or serious deterioration in display quality.

**② Do not operate the LCD module when condensation occurs.**

If the LCD module is operated when condensation is on the terminals of the LCD panel, the terminals cause electrochemical reaction, and may reach disconnection. Condensation easily occurs especially when the module is moved from cold environment to warm environment.

D

D

DOCUMENT CONTROL SECTION

DATE

E

F

						TITLE FLC51UXC8V-10L	
						DRAW. NO. Tech Bes LCD-00239	
						CUST.	
EDIT	DATE	DESIG.	CHECK	APPR.	DESCRIPTION		
DESIG.			CHECK		FUJITSU DISPLAY TECHNOLOGIES CORPORATION		
						28 /	

A

A

**③ The following troubles occur when the LCD module is not used under recommended temperature.**

- Operation under high temperature(>50°C): Display colors shift to blue.
- Storage under high temperature(>60°C): The polarizer film deteriorates and contrast decreases.
- Operation under low temperature(< 0°C): The response speed decreases considerably.
- Storage under low temperature(<-20°C): The liquid crystal may solidify and become damaged.

B

B

**④ Be sure to input the control signals at the correct timing.**

If control signals (DCLK, ENAB) are not input, or if the timing is out of the specified timing, DC voltage may be applied to the liquid crystal and, as a result, cause image sticking or deterioration of contrast.

**(4) Precautions in regards of designing module mounting**

C

C

**① Excessive force should not be applied to the screen or the rear side of the LCD module.**

Excessive pressure on the screen caused by the installation of the LCD module may deteriorate display quality and reliability.  
Brightness uniformity and the reliability of CCFL may decrease if the pressure is applied to the backlight module.

**② Avoid twisting and bending the LCD module.**

Excessive twist and bend may damage display quality and reliability.

**③ Avoid extending the power cable between the LCD module and inverter.**

This may cause the backlight to flicker or not to light.

**④ Keep the backlight cable apart from the metal enclosure of the LCD module.**

When frequency current for backlight driving leak to the metal enclosure, the desired brightness may not be assured.

D

D

**⑤ When Mounting LCD module with M3 screws (x4), tighten the screws with torque below 29.4Nm(3kgf).**

**(5) Storage method**

**① Do not store the LCD module in an atmosphere of organic solvent or corrosive gas.**

In an organic solvent atmosphere, the polarizer film discolors and display quality deteriorates.  
In a corrosive gas environment, various parts of the module may corrode or deteriorate.

**② Store the LCD module in a Fujitsu package.**

At storing, Fujitsu packages can be stacked up to 3 boxes.  
The LCD module is in an anti-static bag. Keep the module in that status.

E

DOCUMENT CONTROL SECTION

DATE

F

						TITLE		FLC51UXC8V-10L		
						DRAW. NO.			CUST.	
						Tech Bes LCD-00239				
EDIT	DATE	DESIG.	CHECK	APPR.	DESCRIPTION				FUJITSU DISPLAY TECHNOLOGIES CORPORATION	29 /
DESIG.			CHECK			APPR.				

③ The LCD module is recommended to be stored in humidity controlled, cool and dark locations.

Recommended storage environment

- Place : Dark (avoid direct sunlight)
- Temperature : 10~35°C
- Humidity : 50~60%RH

Note) If the module is left in an environment of 60°C and above for a long period of time, optical characteristics may deteriorate.

**(6) Disposal Method**

① LCD module

The components of this LCD module can be grouped into metal, resin, glass and so on. As the backlight contains CCFL which includes mercury, it must be disposed according to the local ordinance or regulations.

② Package

All the packages are made of recyclable papers except the anti-ESD bag.

**(7) Others**

① If the LCD panel is damaged, do not inhale and do not swallow the liquid crystal.

If the liquid crystal adhere to the body or cloths, wash it off with soap immediately. Follow regular precautions for electronic components.

② Flux residue on the printed circuit board is harmless to the quality and reliability of LCD module.

Fujitsu has adopted non-wash technology on module assembly process.

DOCUMENT CONTROL SECTION	
DATE	

						TITLE FLC51UXC8V-10L	
						DRAW. NO. Tech Bes LCD-00239	
						CUST.	
EDIT	DATE	DESIG.	CHECK	APPR.	DESCRIPTION		
DESIG.			CHECK		FUJITSU DISPLAY TECHNOLOGIES CORPORATION		
						30 /	

**(8) Return method of the LCD unit requested for repair or analysis of the problem**

- When the LCD unit is packaged and returned, adhere to the following procedures not to damage the LCD panel or the backlight cables. (Fig. 18-1(a)~(b))
- When the LCD unit is returned without following the specified packaging procedures, FDTC will not take responsibility for the damages caused by the failure of the packaging method.

**① Attach protective sheet.**

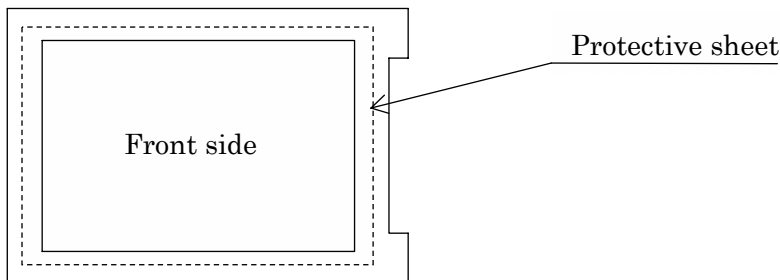

**② Put the LCD unit into the anti-electric bag**

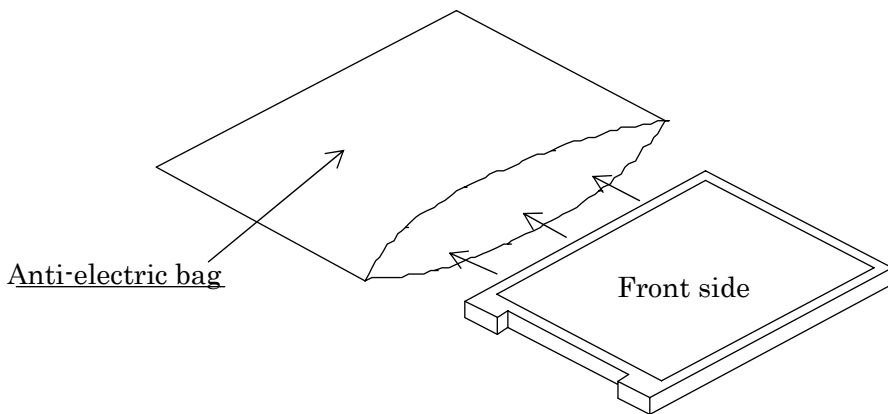

Fig. 17-1(a) Packaging method

DOCUMENT CONTROL SECTION	
DATE	

						TITLE	FLC51UXC8V-10L	
						DRAW. NO.	Tech Bes LCD-00239	CUST.
EDIT	DATE	DESIG.	CHECK	APPR.	DESCRIPTION	FUJITSU DISPLAY TECHNOLOGIES CORPORATION	31 /	
	DESIG.		CHECK		APPR.			





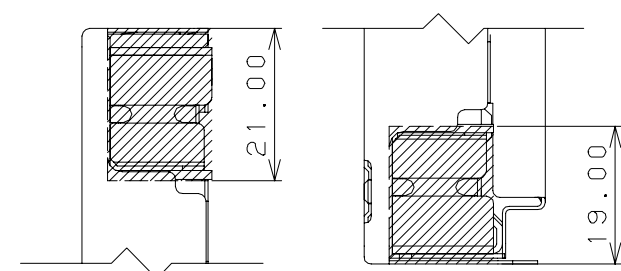
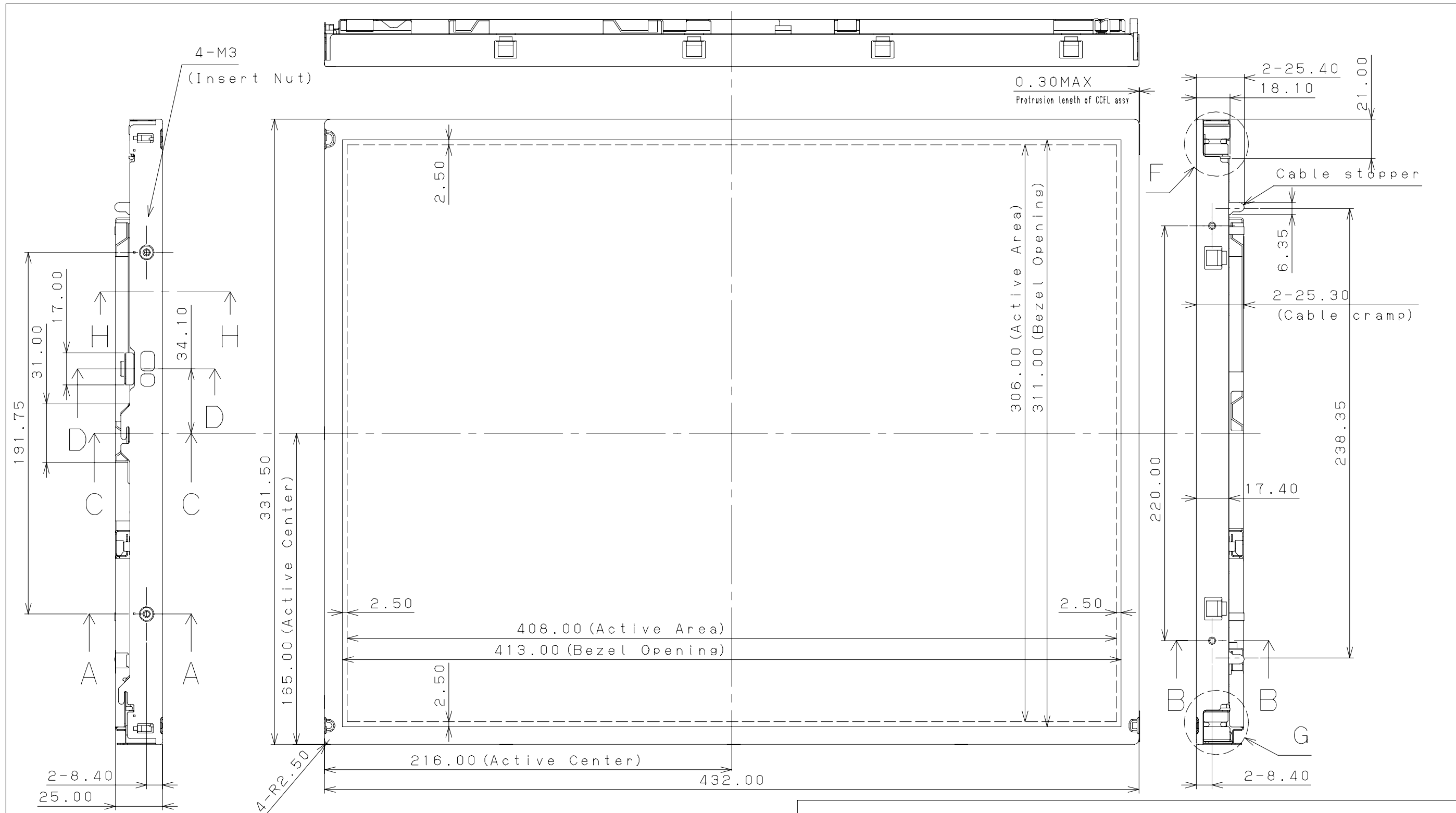

Protrusion area CCFL assy  
Detail F, G

NOTE  
1) Unspecifild tollerrance to be  $\pm 0.5$ .

MATER.		FINISH		TITLE		SCALE	
				FLC51UXC8V-10L		1 : 2	
				DRAW. NO.		Tech Bes LCD-00239	
EDIT.	DATE	DESIG.	CHECK	DESCRIPTION			
DESIG.			CHECK		APPR.	34/	

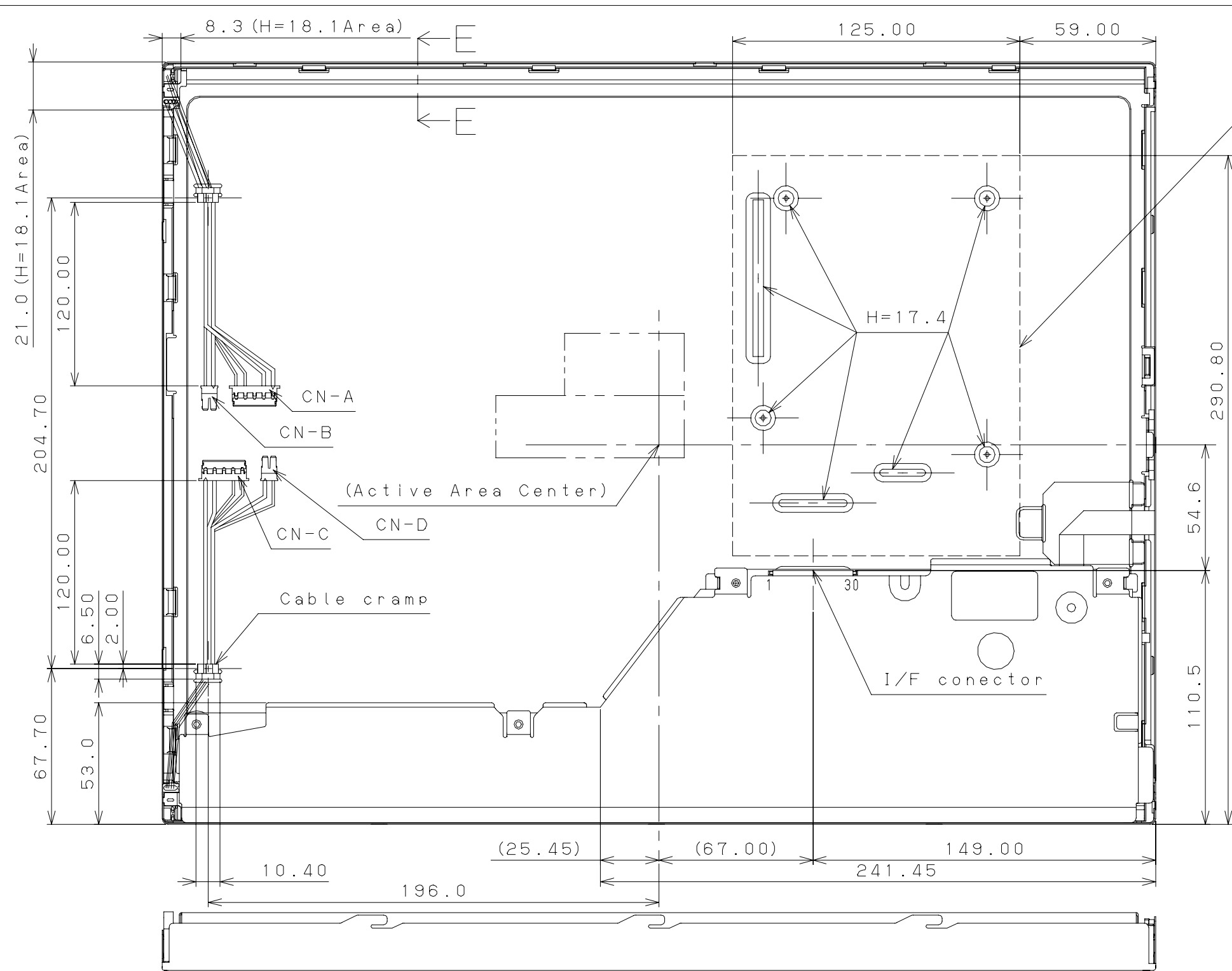

fast response time driving Area  
(H=25.0MAX)

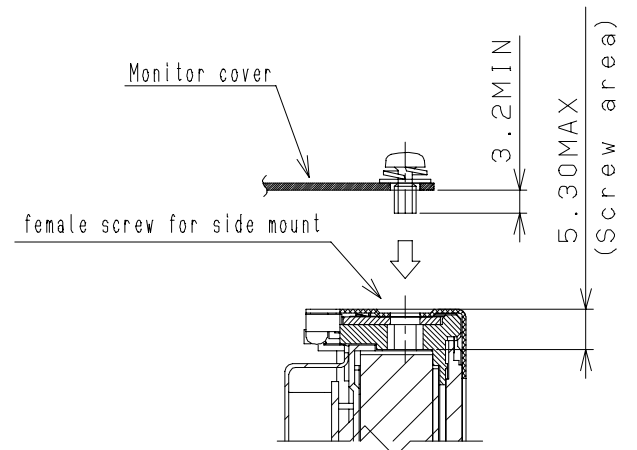
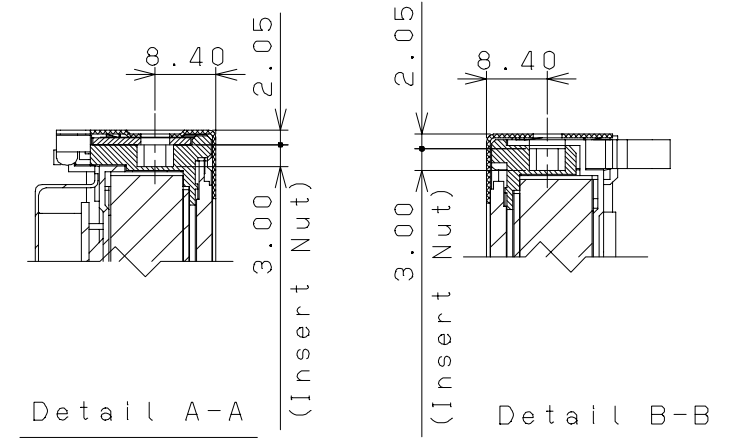

Note 1) Fixing screw of LCD module must have screw part length of more than 3.2mm with unfixing condition. Otherwise fixing screw may not be fixed screwed.  
2) The maximum length of the screw insertion to the side of the LCD module is 5.3mm. If the length of the screw is more than 5.3mm, then the screw may damage the light guide plate which can cause abnormality of display.

Fig. Notice for side mount fixing screw

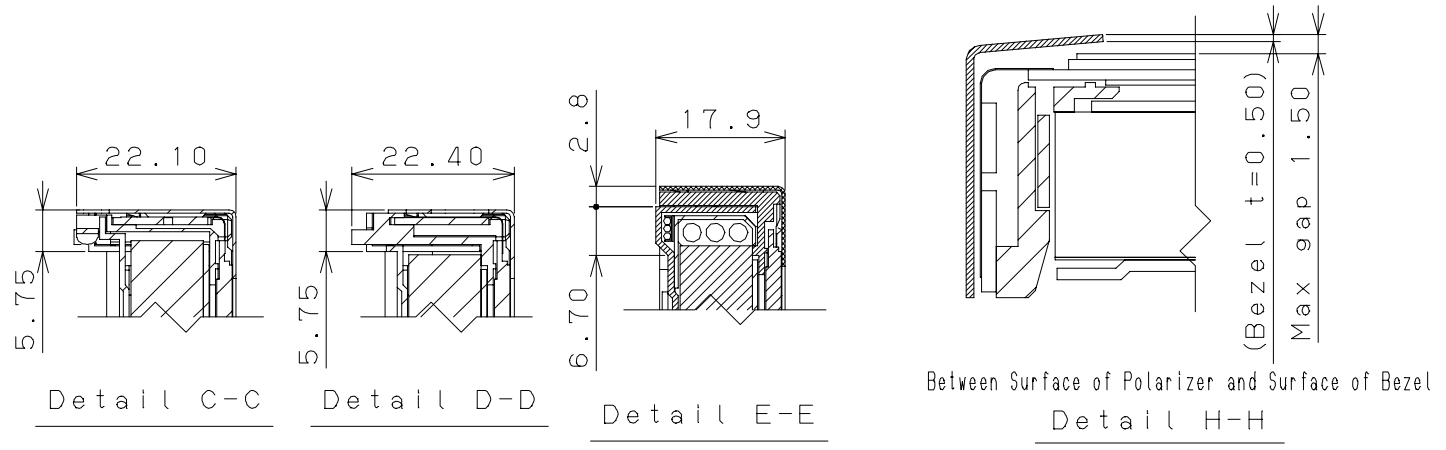

MATER.		FINISH		TITLE FLC51UXC8V-10L		SCALE 1 : 2	
EDIT.		DATE		DRAW. NO. Tech Bes LCD-00239		35 /	
DESIG.	CHECK	DESIG.	CHECK	DESCRIPTION	APPR.		