



Document Title	HSD150PU15 Product Information	Page No.	1 / 31
Document No.		Revision	1.0

# HannStar Product Information

Model : **HSD150PU15**  
**-A**

Issue Date: Jan 23, 2003

- Note:1.The information contained herein is preliminary and may be changed without prior notices.  
2.Please contact HannStar Display Corp. before designing your product based on this module specification.  
3.The information contained herein is presented merely to indicate the characteristics and performance of our products. No responsibility is assumed by HannStar for any intellectual property claims or other problems that may result from application based on the module described here



Document Title	HSD150PU15 Product Information	Page No.	2 / 31
Document No.		Revision	1.0

### Record of Revisions

Rev.	Date	Description of change
1.0	Jan 23, 2003	<ul style="list-style-type: none"><li>• HSD150PU15-A product information was first issued.</li></ul>



Document Title	HSD150PU15 Product Information	Page No.	3 / 31
Document No.		Revision	1.0

## Contents

1.0	General description .....	p. 4
2.0	Absolute maximum ratings .....	p. 5
3.0	Optical characteristics .....	p. 7
4.0	Electrical characteristics .....	p. 11
5.0	Block diagram .....	p. 13
6.0	Interface pin connection .....	p. 14
7.0	Interface timing .....	p. 21
8.0	Outline dimension .....	p. 26
9.0	Lot mark .....	p. 29
10.0	General precaution .....	p. 30

Document Title	HSD150PU15 Product Information	Page No.	4 / 31
Document No.		Revision	1.0

## 1.0 GENERAL DESCRIPTION

### 1.1 Introduction

HannStar Display model HSD150PU15-A is a color active matrix thin film transistor (TFT) liquid crystal display (LCD) that uses amorphous silicon TFT as a switching device. This model is composed of a TFT LCD panel, a driving circuit and a back light system. This TFT LCD has a 15 inch diagonally measured active display area with UXGA resolution (1200 vertical by 1600 horizontal pixel array) and can display up to 262,144 colors.

### 1.2 Features

- 15" UXGA for Notebook PC
- 2ch-LVDS interface system with 6bit color data.
- Compatible with SPWG style-B standard.
- High brightness and Wide viewing angle

### 1.3 Applications

- Notebook PC
- Moniputers
- Display terminals for AV applications
- Monitors for industrial applications

### 1.4 General information

Item	Specification	Unit
Outline dimension(typ.)	317.3(W) × 242.0(H) × 6.5max (D).	mm
Display area	304.8(W) × 228.6(H)(15.0" diagonal)	mm
Number of pixels	1600(H) × 1200(V)	pixels
Pixel pitch	0.1905(H) × 0.1905(V)	mm
Pixel arrangement	RGB vertical stripe	
Display color	6 bit / 262,144 color	
Weight(typ.)	580	g
Back-light	1-CCFL , Side-light type	
Input signal	2-ch LVDS	
Viewing direction	6 o'clock	
Power supply voltage	3.3	V

Document Title	HSD150PU15 Product Information	Page No.	5 / 31
Document No.		Revision	1.0

### 1.5 Mechanical Information

Item		Min.	Typ.	Max.	Unit
Module Size	Horizontal(H)	316.8	317.3	317.8	mm
	Vertical(V)	241.5	242.0	242.5	mm
	Depth(D)	---	6.2	6.5	mm
Weight (Without inverter)		---	580	---	g

## 2.0 ABSOLUTE MAXIMUM RATING

### 2.1 Absolute Rating of Environment

Item	Symbol	Min.	Max.	Unit	Note
Storage temperature	T <sub>STG</sub>	-20	60	°C	
Operating temperature	T <sub>OPR</sub>	0	50	°C	
Operating humidity	H <sub>OPR</sub>	10	80	%RH	(1)
Storage humidity	H <sub>STG</sub>	10	90	%RH	(1)
Vibration(non-operating)	V <sub>nop</sub>	-	1.5	G	(2)
Shock (non-operating)	S <sub>nop</sub>	180	-	G	(3)
Low pressure(operating)	P <sub>LOP</sub>	697	-	hPa	(4)
Low pressure(non-operating)	P <sub>LNOP</sub>	116	-	hPa	(5)

Note (1) Max wet bulb temp =39°C

(2) 5-500Hz sweep/cycle ,X,Y,Z each directions,0.5hr each.

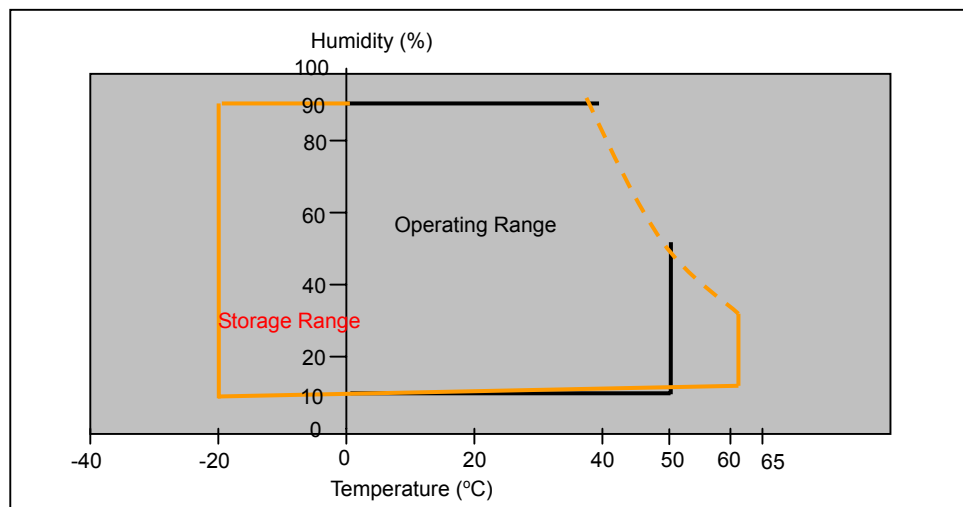

Document Title	HSD150PU15 Product Information	Page No.	6 / 31
Document No.		Revision	1.0

(3) Half sine wave, 2ms,  $\pm X$ ,  $\pm Y$ ,  $\pm Z$  direction, one time each. For this shock test, it is necessary to fill the silicon rubber between the shock jig as buffer.

(4) 2 hours. (10000 feet)

(5) 24 hours. (50000 feet)

## 2.2 Electrical Absolute Ratings

### 2.2.1 TFT LCD Module

Item	Symbol	Min.	Max.	Unit	Note
Power supply voltage	$V_{DD}$	-0.3	4.0	V	(1)
Logic input voltage	$V_{IN}$	-0.3	$V_{DD}+0.3$	V	(1)

### 2.2.2 Back-Light Unit

Item	Symbol	Min.	Max.	Unit	Note
Lamp voltage	$V_{FL}$	0	2000	$V_{(rms)}$	(1)
Lamp current	$I_L$	3.0	7.5	$mA_{(rms)}$	(1)
Lamp frequency	$f_L$	20	100	KHz	(1)

Note (1) Permanent damage may occur to the LCD module if beyond this specification. Functional operation should be restricted to the conditions described under normally operating conditions.

Document Title	HSD150PU15 Product Information	Page No.	7 / 31
Document No.		Revision	1.0

### 3.0 OPTICAL CHARACTERISTICS

#### 3.1 Optical specification

Item		Symbol	Condition	Min.	Typ.	Max.	Unit	Note
Contrast		CR		--	350	-		(1)(2)
Response time	Rising	$T_R$		-	$T_R + T_F$ 35	-	msec	(1)(3)
	Falling	$T_F$		-		-		
White luminance (average of 5 points)		$Y_L$		-	200	-	cd/m <sup>2</sup>	(1)(4) ( $I_L=6.0mA$ )
Color chromaticity (CIE1931)	Red	$R_x$	=0	0.576	0.579	0.582		(1)(4)
		$R_y$	=0	0.346	0.349	0.352		
	Green	$G_x$	Normal Viewing Angle	0.310	0.313	0.316		
		$G_y$		0.570	0.573	0.576		
	Blue	$B_x$		0.151	0.154	0.157		
		$B_y$		0.134	0.137	0.140		
	White	$W_x$			0.31			
		$W_y$			0.33			
Viewing angle	Hor.	L		CR>=10	-	60	-	
		R			-	60	-	
	Ver.	U	-		40	-		
		D	-		60	-		
Brightness uniformity		$B_{UNI}$	=0	65	-	-	%	(4)
Crosstalk		CT(n)	=0	--	-	1.3	%	(5)

#### 3.2 Measuring Condition

- Measuring surrounding : dark room
- Lamp current  $I_{FL}$  :  $6.0 \pm 0.1mA(rms)$ , lamp freq.  $F_L=50 \pm 10$  kHz
- $V_{DD}=3.3V \pm 0.3V$
- Surrounding temperature :  $25 \pm 2^\circ C$
- 30min. warm-up time.

#### 3.3 Measuring Equipment

- LCD-7000 of Otsuka Electrics Corp., which utilized MCPD-7000 for Chromaticity and BM-5A for other optical characteristics.
- Measuring spot size : 10~12mm

Document Title	HSD150PU15 Product Information	Page No.	8 / 31
Document No.		Revision	1.0

Note (1) Definition of Viewing Angle :

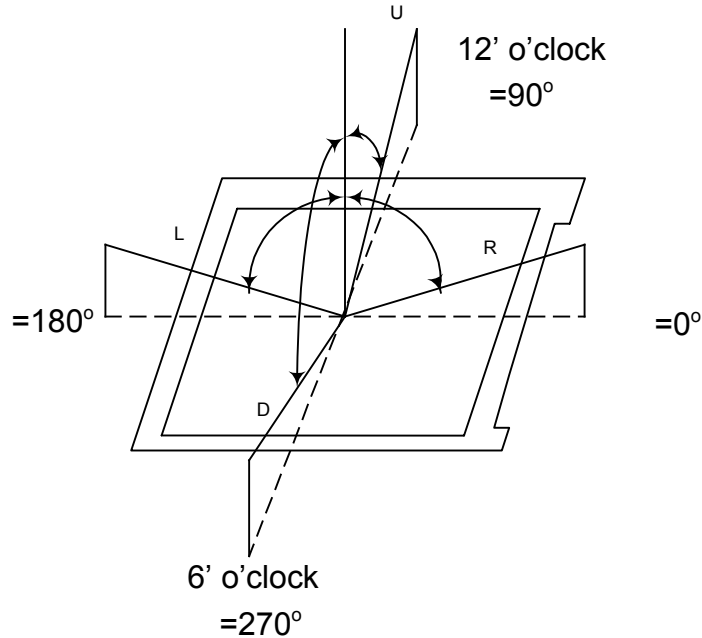

Note (2) Definition of Contrast Ratio(CR) :  
measured at the center point of panel

$$CR = \frac{\text{Luminance with all pixels white (L63)}}{\text{Luminance with all pixels black (L0)}}$$

Note (3) Definition of Response Time : Sum of  $T_R$  and  $T_F$

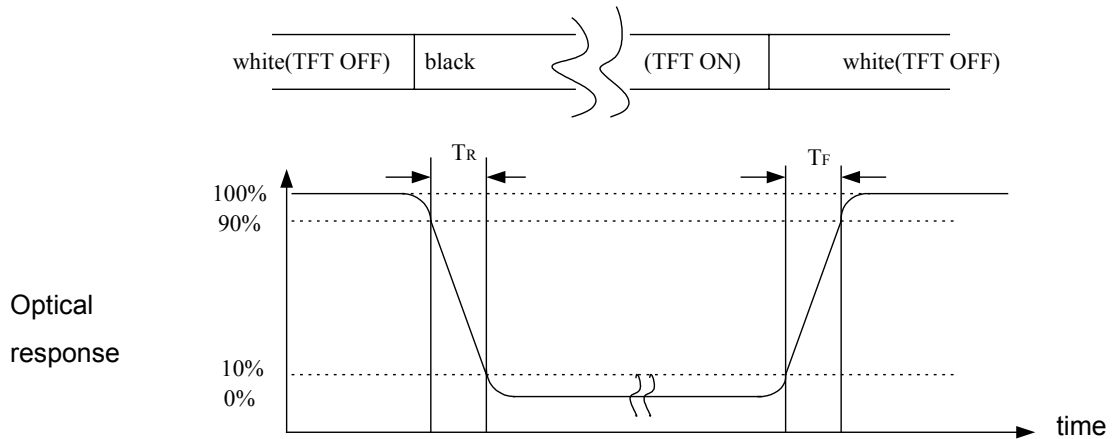

Document Title	HSD150PU15 Product Information	Page No.	9 / 31
Document No.		Revision	1.0

Note (4) Definition of brightness uniformity

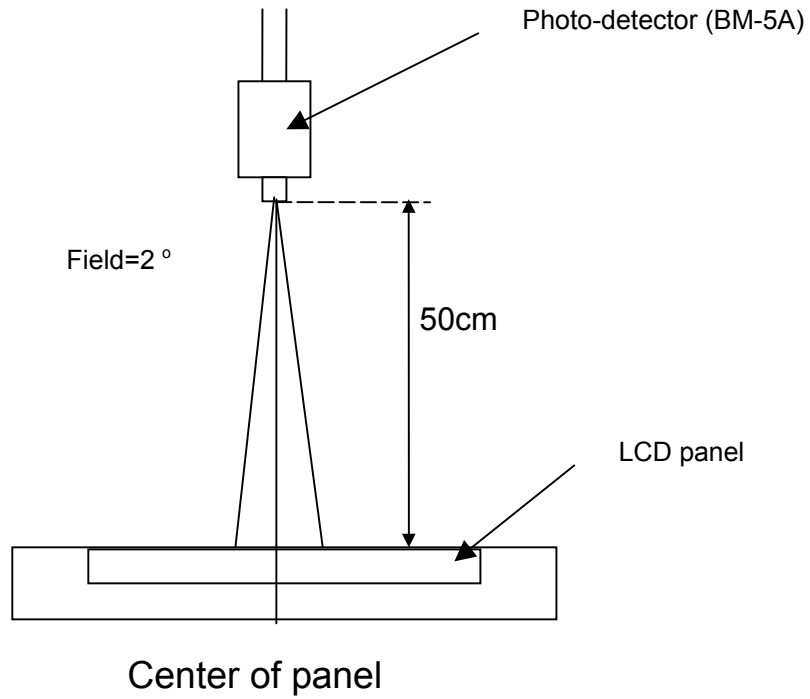

Note (5) Definition of Average Luminance of White (5 Point)

$$\text{Average Luminance} = \frac{Y_1 + Y_2 + Y_3 + Y_4 + Y_5}{5}$$

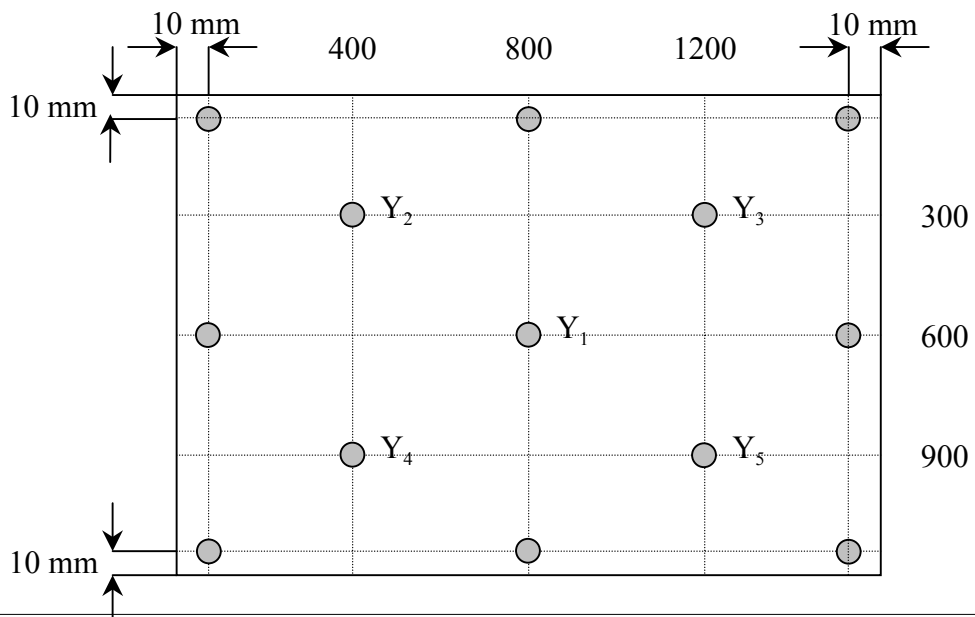

Document Title	HSD150PU15 Product Information	Page No.	10 / 31
Document No.		Revision	1.0

$$\text{Luminance uniformity} = \frac{(\text{Min Luminance of 13 points})}{(\text{Max Luminance of 13 points})} \times 100\%$$

Note (6) Definition of crosstalk CT(1) ~ CT(4)

$$CT(n) = \frac{|L(n) - LB(n)|}{L(n)} \times 100\%, n = 1 \sim 4$$

Where L(n) = Luminance of point "n" at pattern A (cd/m<sup>2</sup>), n=1 ~ 4

LB(n) = Luminance of point "n" at pattern B (cd/m<sup>2</sup>), n=1 ~ 4

The location measured will be exactly the same in both patterns.

L0 : Luminance with all pixels black

L63 : Luminance with all pixels white

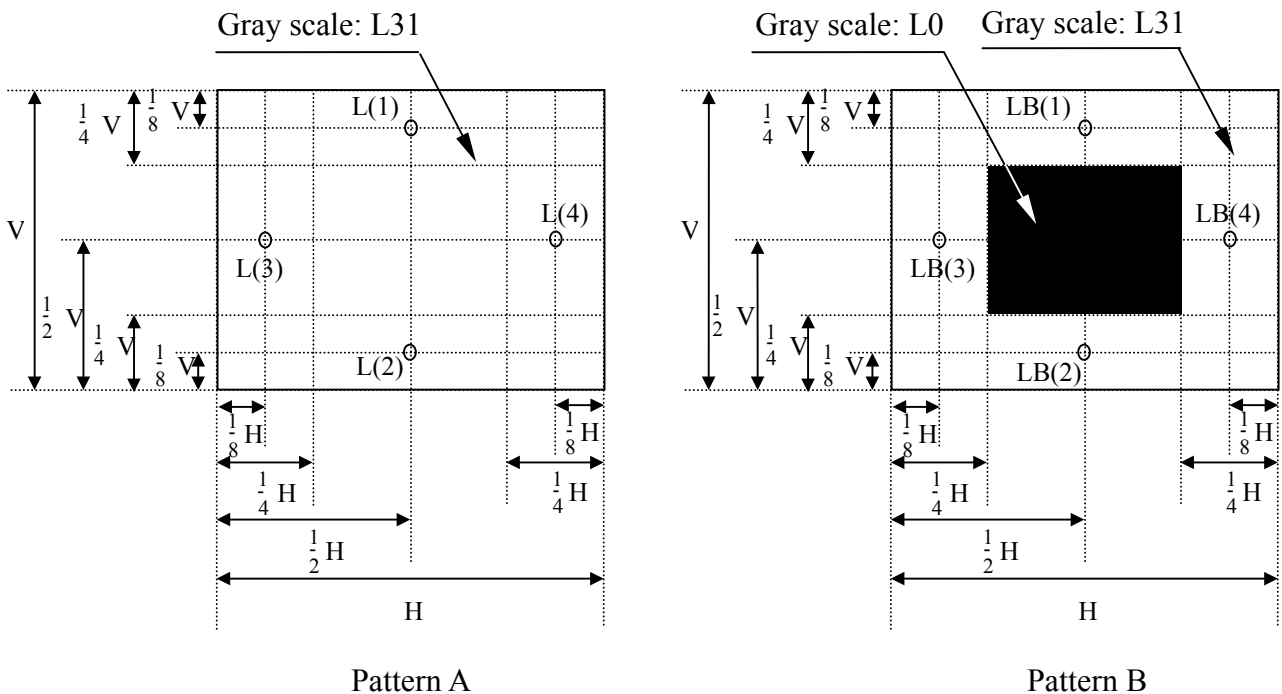

Document Title	HSD150PU15 Product Information	Page No.	11 / 31
Document No.		Revision	1.0

## 4.0 ELECTRICAL CHARACTERISTICS

### 4.1 TFT LCD Module

Item	Symbol	Min.	Typ.	Max.	Unit	Note	
Voltage of power supply	$V_{DD}$	3.0	3.3	3.6	V		
Signal Input voltage	High	$V_{IH}$	-	-	100	MV	$V_{CM}=1.2V$
	Low	$V_{IL}$	-100	-	-	mV	
Current of power supply	Mosaic	$I_{DD}$	520	600	680	mA	(1)
Vsync frequency	$f_V$	-	60.00	60.00	Hz	(2)	
Hsync frequency	$f_H$	-	75.00	-	KHz		
Main frequency	$f_{DCLK}$	75.50	81.00	81.00	MHz		

Note (1) Mosaic : Dot checker image

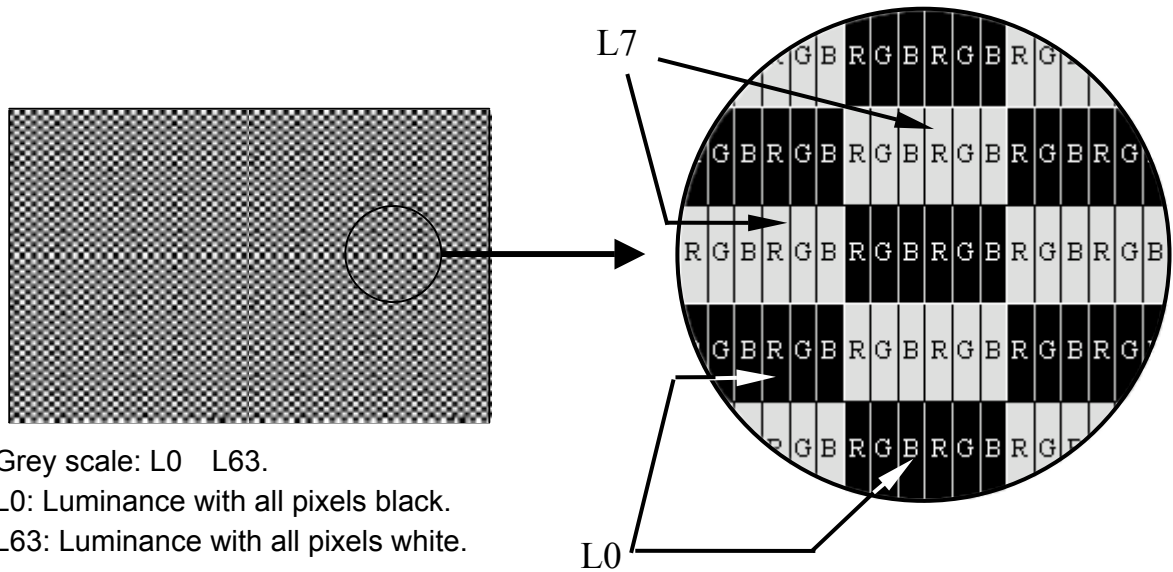

Grey scale: L0 L63.

L0: Luminance with all pixels black.

L63: Luminance with all pixels white.

Note (2) When  $f_V$  is too low, a flicker may be occurred on the display.

Document Title	HSD150PU15 Product Information	Page No.	12 / 31
Document No.		Revision	1.0

#### 4.2 Back-Light Unit

The back-light system is an edge-lighting type with 1 CCFL(Cold Cathode Fluorescent Lamp). The characteristics of the lamp1 are shown in following tables.

Item	Symbol	Min.	Typ.	Max.	Unit	Note
Lamp current	IL	2.0	6.0	6.5	MA(rms)	(1)
Lamp voltage	VL	607	675	743	V(rms)	$I_L=6.0mA$
Frequency	fL	-	52	-	KHz	(2)
Operating life time	Hr	10,000	-	-	Hour	(3)
Startup voltage	Vs	-	-	970	V(rms)	At 0°C(4)

Note (1) Lamp current is measured with current meter for high frequency as shown below. Specified valued are for a lamp.

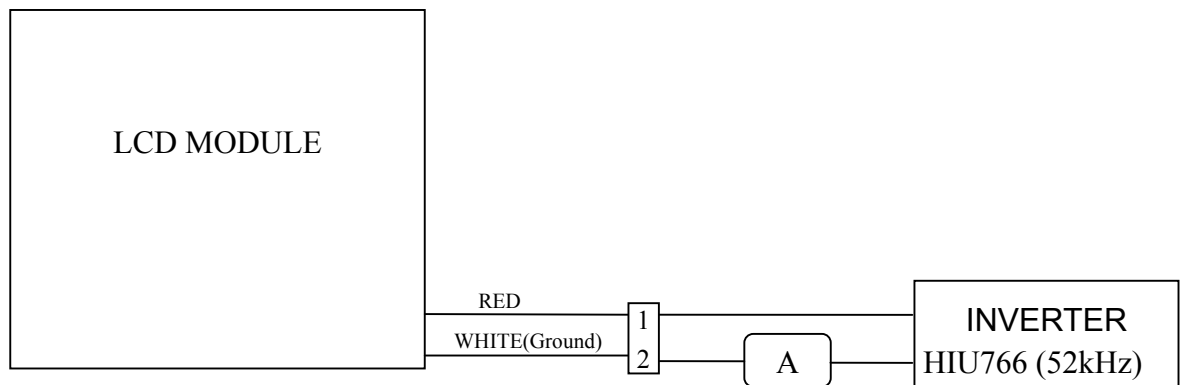

Note (2) Lamp frequency may produce interference with horizontal synchronous frequency and this may cause line flow on the display. Therefore lamp frequency shall be detached from the horizontal synchronous frequency and its harmonics as far as possible in order to avoid interference.

Note (3) Life time (Hr) can be defined as the time in which it continues to operate under the condition:  $T_a=25\pm 3^\circ C$ ,  $I_L=6.0mA(rms)$  and  $f_L=51kHz$  until one of the following event occurs :

1. When the brightness becomes 50%
2. When the startup voltage(Vs) at 0°C becomes higher than the maximal Value of Vs specified above.

Note (4) Max. startup voltage shall be defined as max. voltage which CCFL can be startup. When the customer select the inverter, the min. value of startup voltage must be higher than CCFL's max. startup voltage

Document Title	HSD150PU15 Product Information	Page No.	13 / 31
Document No.		Revision	1.0

## 5.0 BLOCK DIAGRAM

### 5.1 TFT LCD Module

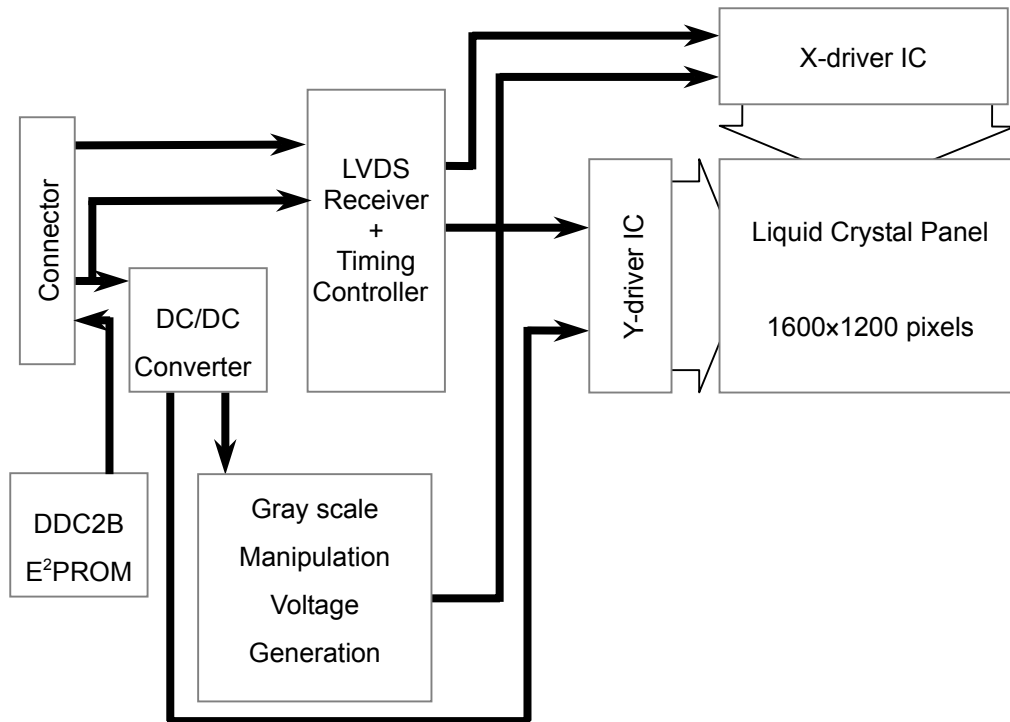

### 5.2 Back Light Unit

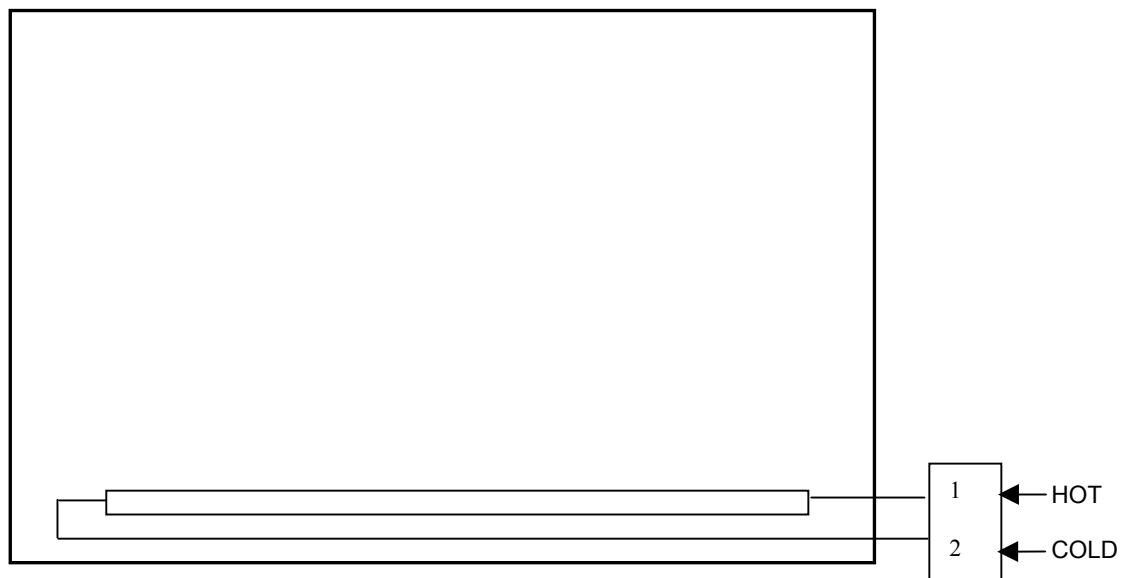

Document Title	HSD150PU15 Product Information	Page No.	14 / 31
Document No.		Revision	1.0

## 6.0 INTERFACE PIN CONNECTION

### 6.1 TFT LCD Module

CN1<sup>1)</sup> INPUT SIGNAL (FI-XB30SR-HF11A/JAPAN AVIATION ELECTRONICS INDUSTRY,LTD.)<sup>1)</sup>

MATING CONNECTOR: FI-X30M,FI-X30MR

Terminal no.	Symbol	Function
1	GND	Ground
2	VDD	Power Supply : +3.3V
3	VDD	Power Supply : +3.3V
4	VEDID	DDC 3.3V power
5	NC	Reserved for supplier test point
6	ClkEDID	DDC clock
7	DATAEDID	DDC data
8	EIN0-	EVEN Transmission Data of Pixels 0 (Negative : -)
9	EIN0+	EVEN Transmission Data of Pixels 0 (Positive : +)
10	GND	Ground
11	EIN1-	EVEN Transmission Data of Pixels 1 (Negative : -)
12	EIN1+	EVEN Transmission Data of Pixels 1 (Positive : +)
13	GND	Ground
14	EIN2-	EVEN Transmission Data of Pixels 2 (Negative : -)
15	EIN2+	EVEN Transmission Data of Pixels 2 (Positive : +)
16	GND	Ground
17	ECLK-	EVEN Sample Clock (Negative : -)
18	ECLK+	EVEN Sample Clock (Positive : +)
19	GND	Ground
20	OIN0-	ODD Transmission Data of Pixels 0 (Negative : -)
21	OIN0+	ODD Transmission Data of Pixels 0 (Positive : +)
22	GND	Ground
23	OIN1-	ODD Transmission Data of Pixels 1 (Negative : -)
24	OIN1+	ODD Transmission Data of Pixels 1 (Positive : +)
25	GND	Ground
26	OIN2-	ODD Transmission Data of Pixels 2 (Negative : -)
27	OIN2+	ODD Transmission Data of Pixels 2 (Positive : +)
28	GND	Ground
29	OCLK-	ODD Sample Clock (Negative : -)
30	OCLK+	ODD Sample Clock (Positive : +)

Note 1) Please connects NC pin to nothing. Don't connect it to ground nor to other signal input.  
(NC pin should be open.)

### 6.2 Back-Light Unit

CN2 CCFL Power Source (BHSR-02VS-1) / JAPAN SOLDERLESS TERMINAL MFG CO., LTD.

Terminal no.	Symbol	Function
1	V <sub>L</sub>	CCFL power supply (high voltage)
2	G <sub>L</sub>	CCFL power supply (low voltage)



Document Title	HSD150PU15 Product Information	Page No.	15 / 31
Document No.		Revision	1.0

### 6.3 Relationship Between Displayed Color and Input

	Display	MSB						LSB						Gray scale level						
		R5	R4	R3	R2	R1	R0	G5	G4	G3	G2	G1	G0		B5	B4	B3	B2	B1	B0
Basic color	Black	L	L	L	L	L	L	L	L	L	L	L	L	L	L	L	L	L	L	-
	Blue	L	L	L	L	L	L	L	L	L	L	L	L	H	H	H	H	H	H	-
	Green	L	L	L	L	L	L	H	H	H	H	H	H	L	L	L	L	L	L	-
	Light Blue	L	L	L	L	L	L	H	H	H	H	H	H	H	H	H	H	H	H	-
	Red	H	H	H	H	H	H	L	L	L	L	L	L	L	L	L	L	L	L	-
	Purple	H	H	H	H	H	H	L	L	L	L	L	L	H	H	H	H	H	H	-
	Yellow	H	H	H	H	H	H	H	H	H	H	H	H	L	L	L	L	L	L	-
	White	H	H	H	H	H	H	H	H	H	H	H	H	H	H	H	H	H	H	-
Gray scale of Red	Black	L	L	L	L	L	L	L	L	L	L	L	L	L	L	L	L	L	L	L0
	Dark ↑ Light	L	L	L	L	L	H	L	L	L	L	L	L	L	L	L	L	L	L	L1
		L	L	L	L	H	L	L	L	L	L	L	L	L	L	L	L	L	L	L2
		:	:	:	:	:	:	:	:	:	:	:	:	:	:	:	:	:	:	L3... L60
		H	H	H	H	L	H	L	L	L	L	L	L	L	L	L	L	L	L	L61
		H	H	H	H	H	L	L	L	L	L	L	L	L	L	L	L	L	L	L62
	Red	H	H	H	H	H	H	L	L	L	L	L	L	L	L	L	L	L	L	Red L63
Gray scale of Green	Black	L	L	L	L	L	L	L	L	L	L	L	L	L	L	L	L	L	L	L0
	Dark ↑ Light	L	L	L	L	L	L	L	L	L	L	L	H	L	L	L	L	L	L	L1
		L	L	L	L	L	L	L	L	L	L	H	L	L	L	L	L	L	L	L2
		:	:	:	:	:	:	:	:	:	:	:	:	:	:	:	:	:	:	L3... L60
		L	L	L	L	L	L	H	H	H	H	L	H	L	L	L	L	L	L	L61
		L	L	L	L	L	L	H	H	H	H	H	L	L	L	L	L	L	L	L62
	Green	L	L	L	L	L	L	H	H	H	H	H	H	L	L	L	L	L	L	Green L63
Gray scale of Blue	Black	L	L	L	L	L	L	L	L	L	L	L	L	L	L	L	L	L	L	L0
	Dark ↑ Light	L	L	L	L	L	L	L	L	L	L	L	L	L	L	L	L	L	H	L1
		L	L	L	L	L	L	L	L	L	L	L	L	L	L	L	L	H	L	L2
		:	:	:	:	:	:	:	:	:	:	:	:	:	:	:	:	:	:	L3... L60
		L	L	L	L	L	L	L	L	L	L	L	L	H	H	H	H	L	H	L61
		L	L	L	L	L	L	L	L	L	L	L	L	H	H	H	H	H	L	L62
	Blue	L	L	L	L	L	L	L	L	L	L	L	L	H	H	H	H	H	H	Blue L63
Gray scale of White & Black	Black	L	L	L	L	L	L	L	L	L	L	L	L	L	L	L	L	L	L	L0
	Dark ↑ Light	L	L	L	L	L	H	L	L	L	L	L	H	L	L	L	L	L	H	L1
		L	L	L	L	H	L	L	L	L	L	H	L	L	L	L	L	H	L	L2
		:	:	:	:	:	:	:	:	:	:	:	:	:	:	:	:	:	:	L3... L60
		H	H	H	H	L	H	H	H	H	H	L	H	H	H	H	H	L	H	L61
		H	H	H	H	H	L	H	H	H	H	H	L	H	H	H	H	H	L	L62
	White	H	H	H	H	H	H	H	H	H	H	H	H	H	H	H	H	H	H	White L63

Document Title	HSD150PU15 Product Information	Page No.	16 / 31
Document No.		Revision	1.0

### 6.4 Pixel Format

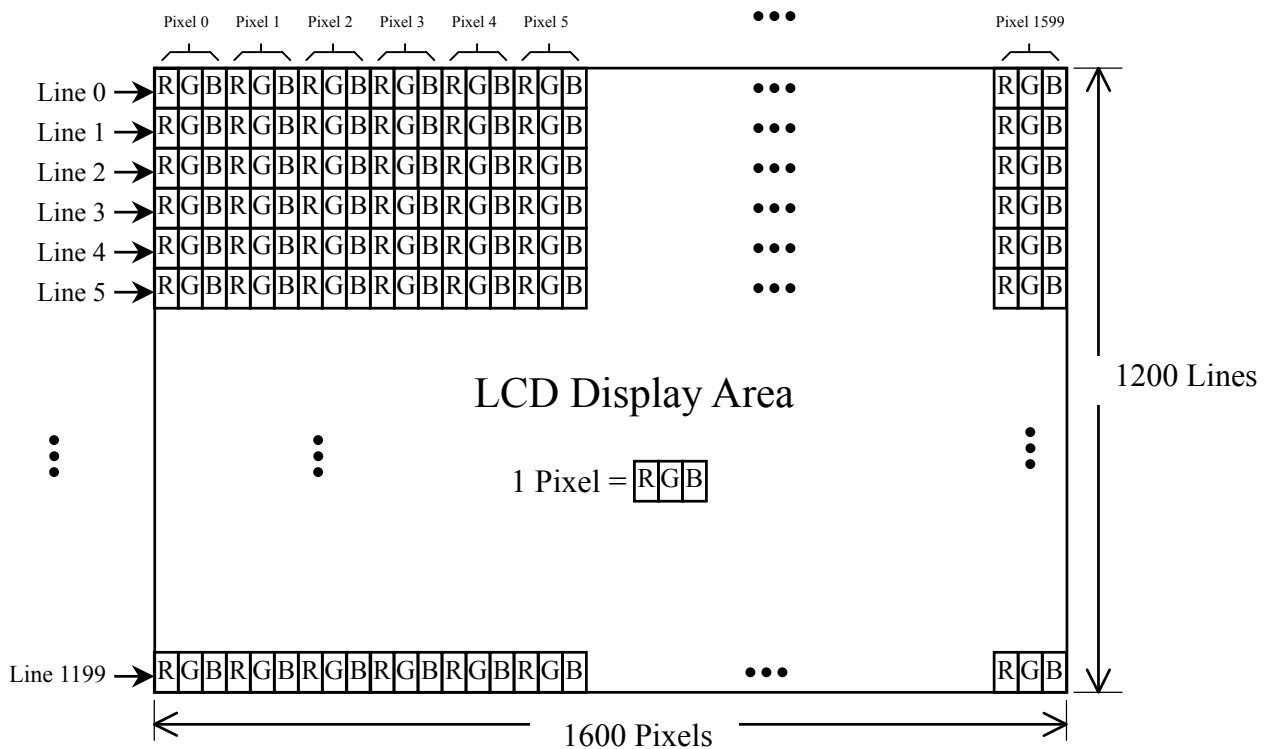

Note: The first pixel is Even pixel.

Document Title	HSD150PU15 Product Information	Page No.	17 / 31
Document No.		Revision	1.0

### 6.5 RECOMMENDED TRANSMITTER TO HSD150PU15-A INTERFACE ASSIGNMENT

#### Case1: EVEN DATA (6bit transmitter)

THC63LVDM63A						
Input terminal no.		Input signal (Graphics controller output signal)		Output signal	HSD150PU15-A interface(CN1)	
Symbol	Terminal	Symbol	Function	Symbol	Terminal	Symbol
T1IN0/TA0	44	RE0	RED Pixels Display Data (LSB)	T1OUT0- T1OUT0+	No. 8 No. 9	EIN0- EIN0+
T1IN1/TA1	45	RE1	RED Pixels Display Data			
T1IN2/TA2	47	RE2	RED Pixels Display Data			
T1IN3/TA3	48	RE3	RED Pixels Display Data			
T1IN4/TA4	1	RE4	RED Pixels Display Data			
T1IN5/TA5	3	RE5	RED Pixels Display Data (MSB)			
T1IN6/TA6	4	GE0	GREEN Pixels Display Data (LSB)	T1OUT1- T1OUT1+	No. 11 No. 12	EIN1- EIN1+
T1IN7/TB0	6	GE1	GREEN Pixels Display Data			
T1IN8/TB1	7	GE2	GREEN Pixels Display Data			
T1IN9/TB2	9	GE3	GREEN Pixels Display Data			
T1IN10/TB3	10	GE4	GREEN Pixels Display Data			
T1IN11/TB4	12	GE5	GREEN Pixels Display Data (MSB)			
T1IN12/TB5	13	BE0	BLUE Pixels Display Data (LSB)	T1OUT2- T1OUT2+	No. 14 No. 15	EIN2- EIN2+
T1IN13/TB6	15	BE1	BLUE Pixels Display Data			
T1IN14/TC0	16	BE2	BLUE Pixels Display Data			
T1IN15/TC1	18	BE3	BLUE Pixels Display Data			
T1IN16/TC2	19	BE4	BLUE Pixels Display Data			
T1IN17/TC3	20	BE5	BLUE Pixels Display Data (MSB)			
T1IN18/TC4	22	HSYNC	H-Sync	T1CLK OUT- T1CLK OUT+	No. 17 No. 18	ECLK - ECLK +
T1IN19/TC5	23	VSYNC	V-Sync			
T1IN20/TC6	25	DE	Data Enable Signal			
T1CLK IN /CLKIN	26	NCLK	Data Sampling Clock			

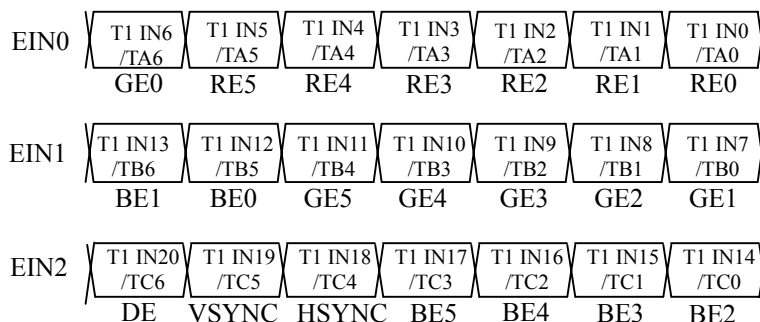

Document Title	HSD150PU15 Product Information	Page No.	18 / 31
Document No.		Revision	1.0

**ODD DATA(6bit transmitter)**

THC63LVDM63A						
Input terminal no.		Input signal (Graphics controller output signal)		Output signal	HSD150PU15-A Interface(CN1)	
Symbol	Terminal	Symbol	Function	Symbol	Terminal	Symbol
T2IN0/TA0	44	RO0	RED Pixels Display Data (LSB)	T2OUT0- T2OUT0+	No. 20 No. 21	OIN0- OIN0+
T2IN1/TA1	45	RO1	RED Pixels Display Data			
T2IN2/TA2	47	RO2	RED Pixels Display Data			
T2IN3/TA3	48	RO3	RED Pixels Display Data			
T2IN4/TA4	1	RO4	RED Pixels Display Data			
T2IN5/TA5	3	RO5	RED Pixels Display Data (MSB)			
T2IN6/TA6	4	GO0	GREEN Pixels Display Data (LSB)	T2OUT1- T2OUT1+	No. 23 No. 24	OIN1- OIN1+
T2IN7/TB0	6	GO1	GREEN Pixels Display Data			
T2IN8/TB1	7	GO2	GREEN Pixels Display Data			
T2IN9/TB2	9	GO3	GREEN Pixels Display Data			
T2IN10/TB3	10	GO4	GREEN Pixels Display Data			
T2IN11/TB4	12	GO5	GREEN Pixels Display Data (MSB)			
T2IN12/TB5	13	BO0	BLUE Pixels Display Data (LSB)	T2OUT2- T2OUT2+	No. 26 No. 27	OIN2- OIN2+
T2IN13/TB6	15	BO1	BLUE Pixels Display Data			
T2IN14/TC0	16	BO2	BLUE Pixels Display Data			
T2IN15/TC1	18	BO3	BLUE Pixels Display Data			
T2IN16/TC2	19	BO4	BLUE Pixels Display Data			
T2IN17/TC3	20	BO5	BLUE Pixels Display Data (MSB)			
T2IN18/TC4	22	NC	Non Connection(open)	T2CLK OUT- T2CLK OUT+	No. 29 No. 30	OCLK - OCLK+
T2IN19/TC5	23	NC	Non Connection(open)			
T2IN20/TC6	25	NC	Non Connection(open)			
T1CLK IN /CLKIN	26	NCLK	Data Sampling Clock			

Note : Please connect NC pin to nothing. Don't connect it to ground nor to other signal input.

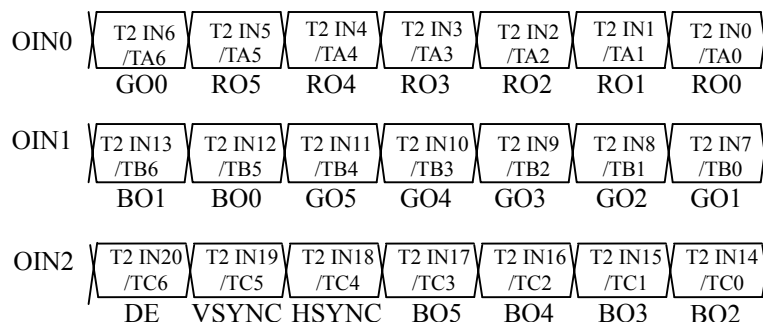

Document Title	HSD150PU15 Product Information	Page No.	19 / 31
Document No.		Revision	1.0

**Case2 : EVEN DATA (8bit transmitter)**

THC63LVDM83A						
Input terminal no.		Input signal (Graphics control output signal)		Output signal	HSD150PU15-A Interface(CN1)	
Symbol	Terminal	Symbol	Function	Symbol	Terminal	Symbol
T1IN0/TA0	51	RE0	RED Pixels Display Data (LSB)	T1OUT0- T1OUT0+	No. 8 No. 9	EIN0- EIN0+
T1IN1/TA1	52	RE1	RED Pixels Display Data			
T1IN2/TA2	54	RE2	RED Pixels Display Data			
T1IN3/TA3	55	RE3	RED Pixels Display Data			
T1IN4/TA4	56	RE4	RED Pixels Display Data			
T1IN5/TA5	3	RE5	RED Pixels Display Data (MSB)			
T1IN6/TA6	4	GE0	GREEN Pixels Display Data (LSB)	T1OUT1- T1OUT1+	NO.11 NO.12	EIN1- EIN1+
T1IN7/TB0	6	GE1	GREEN Pixels Display Data			
T1IN8/TB1	7	GE2	GREEN Pixels Display Data			
T1IN9/TB2	11	GE3	GREEN Pixels Display Data			
T1IN10/TB3	12	GE4	GREEN Pixels Display Data			
T1IN11/TB4	14	GE5	GREEN Pixels Display Data (MSB)			
T1IN12/TB5	15	BE0	BLUE Pixels Display Data (LSB)	T1OUT2- T1OUT2+	NO.14 NO.15	EIN2- EIN2+
T1IN13/TB6	19	BE1	BLUE Pixels Display Data			
T1IN14/TC0	20	BE2	BLUE Pixels Display Data			
T1IN15/TC1	22	BE3	BLUE Pixels Display Data			
T1IN16/TC2	23	BE4	BLUE Pixels Display Data			
T1IN17/TC3	24	BE5	BLUE Pixels Display Data (MSB)			
T1IN18/TC4	27	HSYNC	H-Sync	T1OUT3- T1OUT3+	NC NC	NC NC
T1IN19/TC5	28	VSYNC	V-Sync			
T1IN20/TC6	30	DE	Data Enable Signal			
T1IN21/TD0	50	NC	Non Connection (open)			
T1IN22/TD1	2	NC	Non Connection (open)			
T1IN23/TD2	8	NC	Non Connection (open)			
T1IN24/TD3	10	NC	Non Connection (open)	T1CLK OUT- T1CLK OUT+	NO. 17 NO. 18	ECLK - ECLK +
T1IN25/TD4	16	NC	Non Connection (open)			
T1IN26/TD5	18	NC	Non Connection (open)			
T1IN27/TD6	25	NC	Non Connection (open)			
T1CLK IN /CLKIN	31	NCLK	DATA SAMPLING CLOCK			

Note : Please connect NC pin to nothing. Don't connect it to ground nor to other signal input.

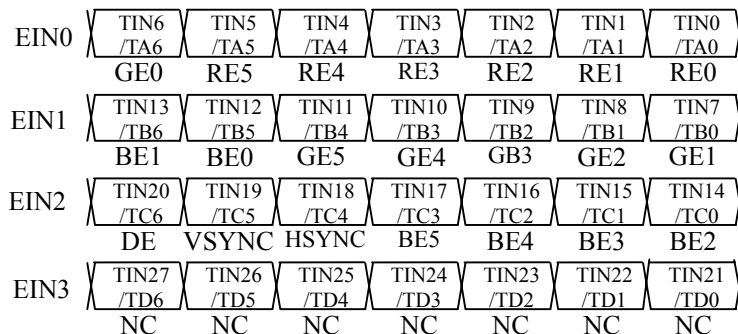

Document Title	HSD150PU15 Product Information	Page No.	20 / 31
Document No.		Revision	1.0

**ODD DATA (8bit transmitter)**

THC63LVDM83A						
Input terminal no.		Input signal (Graphics control output signal)		Output signal	HSD150PU15-A Interface(CN1)	
Symbol	Terminal	Symbol	Function	Symbol	Terminal	Symbol
T2IN0/TA0	51	RO0	RED Pixels Display Data (LSB)	T2OUT0- T2OUT0+	No. 20 No. 21	OIN0- OIN0+
T2IN1/TA1	52	RO1	RED Pixels Display Data			
T2IN2/TA2	54	RO2	RED Pixels Display Data			
T2IN3/TA3	55	RO3	RED Pixels Display Data			
T2IN4/TA4	56	RO4	RED Pixels Display Data			
T2IN5/TA5	3	RO5	RED Pixels Display Data (MSB)			
T2IN6/TA6	4	GO0	GREEN Pixels Display Data (LSB)	T2OUT1- T2OUT1+	NO.23 NO.24	OIN1- OIN1+
T2IN7/TB0	6	GO1	GREEN Pixels Display Data			
T2IN8/TB1	7	GO2	GREEN Pixels Display Data			
T2IN9/TB2	11	GO3	GREEN Pixels Display Data			
T2IN10/TB3	12	GO4	GREEN Pixels Display Data			
T2IN11/TB4	14	GO5	GREEN Pixels Display Data (MSB)			
T2IN12/TB5	15	BO0	BLUE Pixels Display Data (LSB)	T2OUT2- T2OUT2+	NO.26 NO.27	OIN2- OIN2+
T2IN13/TB6	19	BO1	BLUE Pixels Display Data			
T2IN14/TC0	20	BO2	BLUE Pixels Display Data			
T2IN15/TC1	22	BO3	BLUE Pixels Display Data			
T2IN16/TC2	23	BO4	BLUE Pixels Display Data			
T2IN17/TC3	24	BO5	BLUE Pixels Display Data (MSB)			
T2IN18/TC4	27	NC	Non Connection (open)	T2OUT3- T2OUT3+	NC NC	- -
T2IN19/TC5	28	NC	Non Connection (open)			
T2IN20/TC6	30	NC	Non Connection (open)			
T2IN21/TD0	50	NC	Non Connection (open)			
T2IN22/TD1	2	NC	Non Connection (open)			
T2IN23/TD2	8	NC	Non Connection (open)			
T2IN24/TD3	10	NC	Non Connection (open)	T2CLK OUT- T2CLK OUT+	NO. 29 NO. 30	OCLK - OCLK +
T2IN25/TD4	16	NC	Non Connection (open)			
T2IN26/TD5	18	NC	Non Connection (open)			
T2IN27/TD6	25	NC	Non Connection (open)			
T2CLK IN /CLKIN	31	NCLK	DATA SAMPLING CLOCK			

Note : Please connect NC pin to nothing. Don't connect it to ground nor to other signal input.

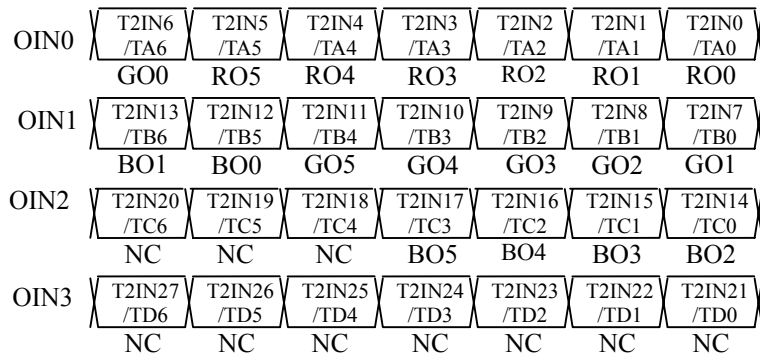

Document Title	HSD150PU15 Product Information	Page No.	21 / 31
Document No.		Revision	1.0

## 7.0 INTERFACE TIMING <sup>1)2)3)4)5)6)</sup>

### 7.1 Timing Parameters (Hsync, Vsync and DE mode)

Item	Symbol	Min.	Typ.	Max.	Unit
Frame Period	t1	1210 × t4	1250 × t4	1250 × t4	
			16.67	16.67	Ms
Vertical Display Term	t2	1200 × t4	1200 × t4	1200 × t4	
Vertical Blanking Term	t3	10 × t4	50 × t4	50 × t4	
1 Line Scanning Time	t4	1040 × t7	1080 × t7	1080 × t7	
			13.33		Us
Horizontal Display Term	t5	800 × t7	800 × t7	800 × t7	
Horizontal Blanking Term	t6	240 × t7	280 × t7	280 × t7	
Clock Period	t7	12.346	12.346	13.244	Ns
V-Sync Pulse Width	tvw	2 × t4			
V-Sync Set up Time	tvsu	8 × t7			
V-Sync Hold Time	tvhd	8 × t7			
Vertical Front Porch	tvfp	2 × t4			
Vertical Data Sync Period	tvds	8 × t4			
Horizontal Period	th	1040 × t7	1080 × t7	1080 × t7	
H-Sync Pulse Width	thw	4 × t7			
Horizontal Front Porch	thfp	4 × t7			
Horizontal Data Sync Period	thds	t6 - thfp	t6 - thfp	t6 - thfp	
DE Pulse Width	twde	800 × t7	800 × t7	800 × t7	
Clock	Low time	t8	5		Ns
	High time	t9	5		Ns
Data	Setup time	t10	2		Ns
	Hold time	t11	5		Ns

$$t3 = tvfp + tvds \quad t4 = th \quad t6 = thfp + thds$$

Note 1) Refer to “7.2 Timing Chart” and LVDS(THC63LVDF84A) specifications by THine Electronic, Inc..

Note 2) If ENAB is fixed to “H” or “L” level for certain period while NCLK is supplied, the panel displays black with some flicker.

Note 3) If NCLK is fixed to “H” or “L” level for certain period while ENAB is supplied, the panel may be damaged.

Note 4) Please adjust LCD operating signal timing and FL driving frequency, to optimize the display quality. There is a possibility that flicker is observed by the interference of LCD operating signal timing and FL driving condition (especially driving frequency), even if the condition satisfies above timing specifications and recommended operating conditions shown in 3.

Note 5) Do not make t1, t2, t3 and tvds fluctuate. If t1, t2, t3 and tvds are fluctuate, the panel displays black.

Note 6) In case of using the long frame period, the deterioration of display quality, noise etc. may be occurred.

Note 7) NCLK count of each Horizontal Scanning Time should be always the same.

V-Blanking period should be “n” X “Horizontal scanning Time” (n : integer).

Frame period should be always the same.

Document Title	HSD150PU15 Product Information	Page No.	22 / 31
Document No.		Revision	1.0

## 7.2 Timing Diagram of Interface Signal (Hsync, Vsync and DE mode)

### 7.2.1 Vertical Timing

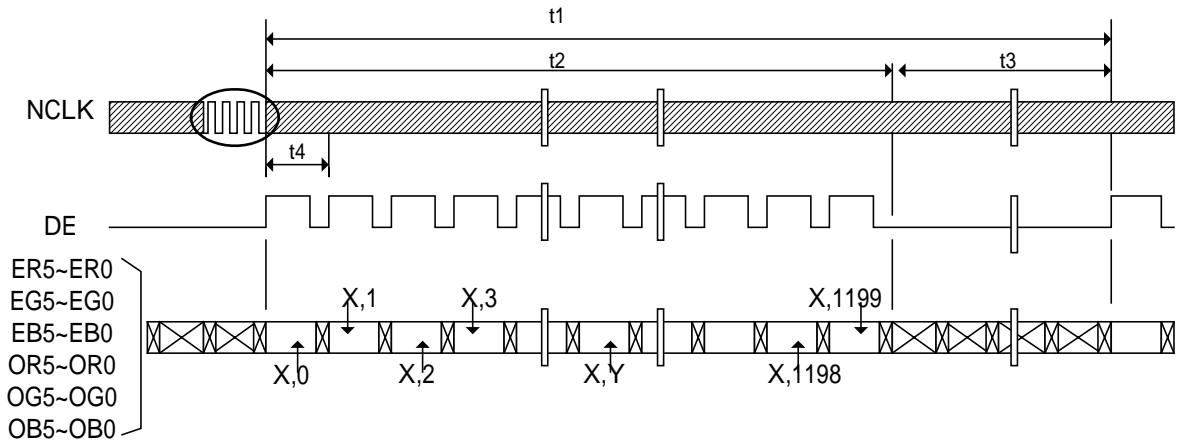

### 7.2.2 Horizontal Timing

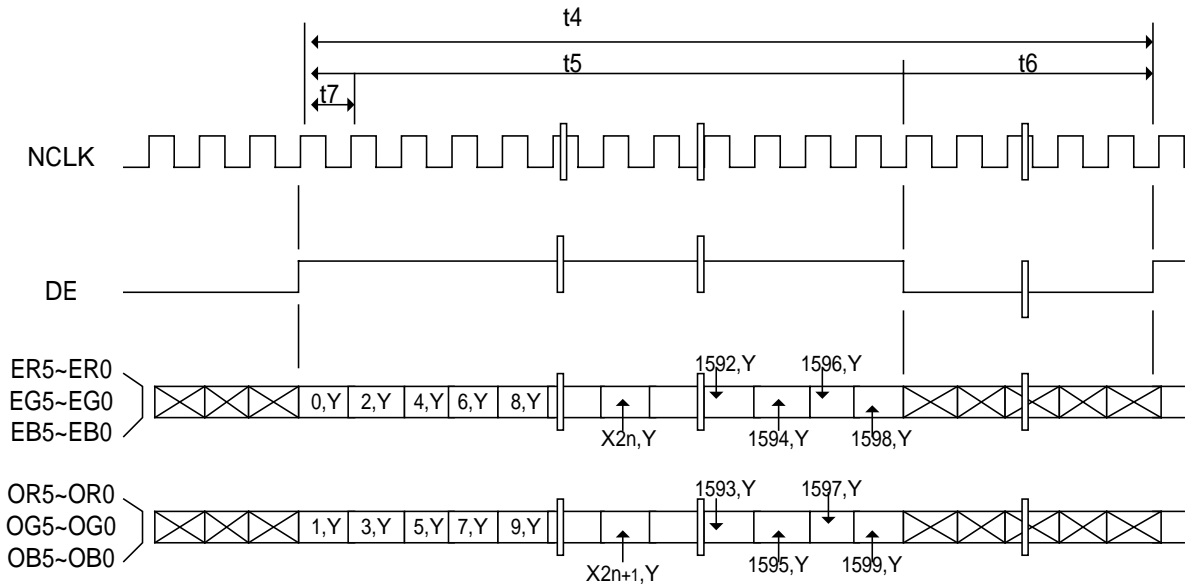

Document Title	HSD150PU15 Product Information	Page No.	23 / 31
Document No.		Revision	1.0

### 7.2.3 SYNC Timing

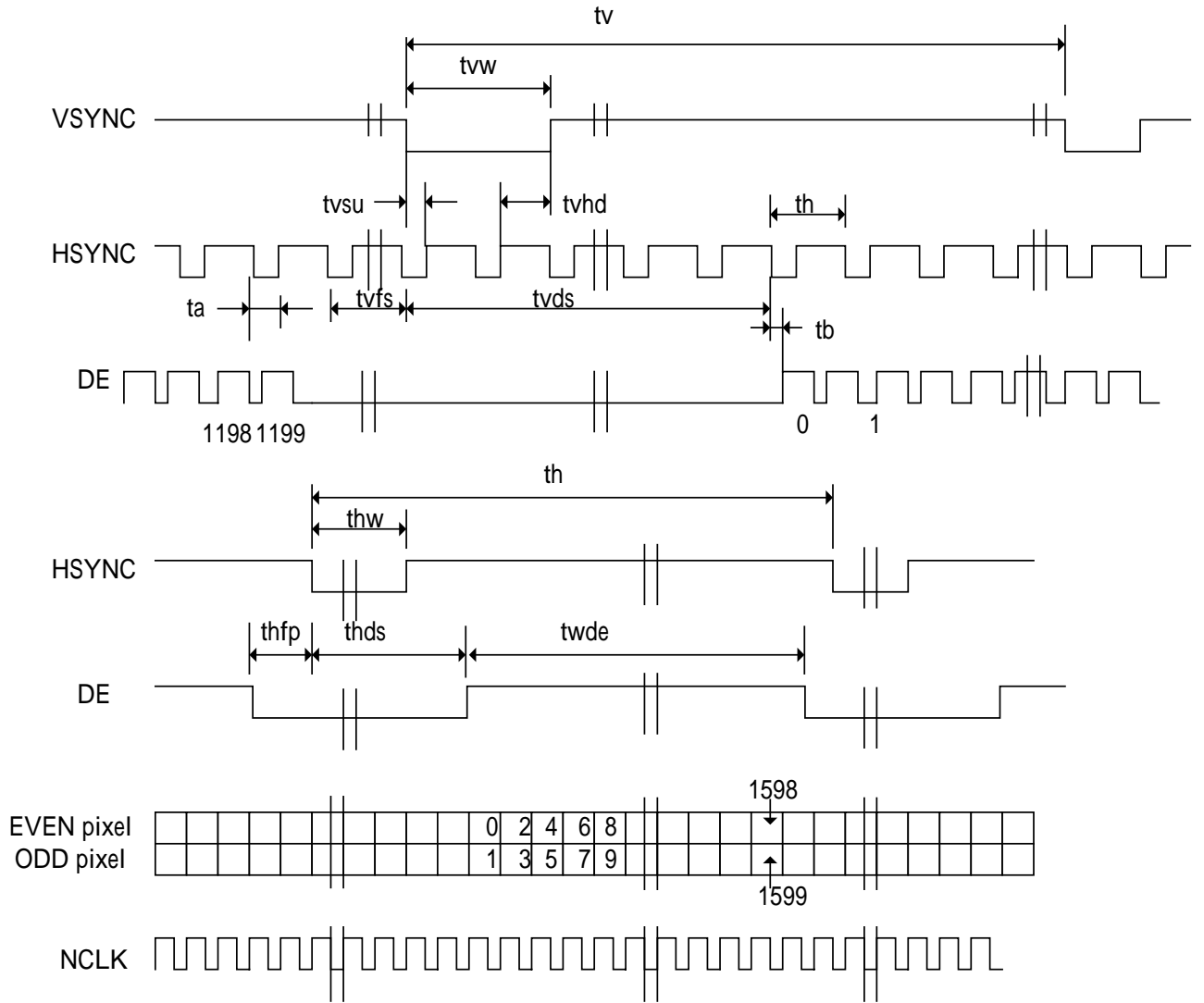

Document Title	HSD150PU15 Product Information	Page No.	24 / 31
Document No.		Revision	1.0

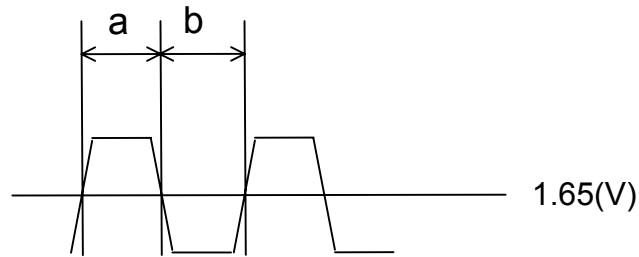

Duty(a,b) : 50±10%

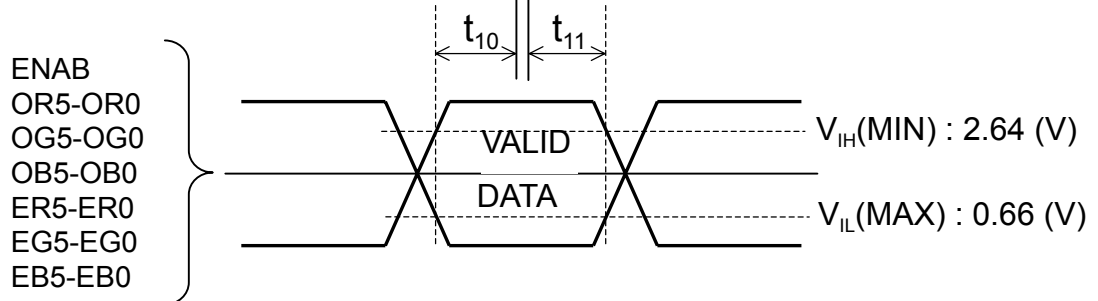
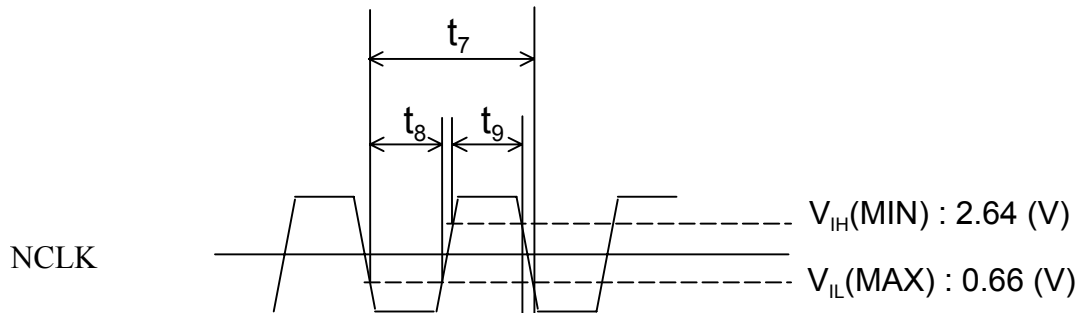

Document Title	HSD150PU15 Product Information	Page No.	25 / 31
Document No.		Revision	1.0

### 7.3 Power ON/OFF Sequence

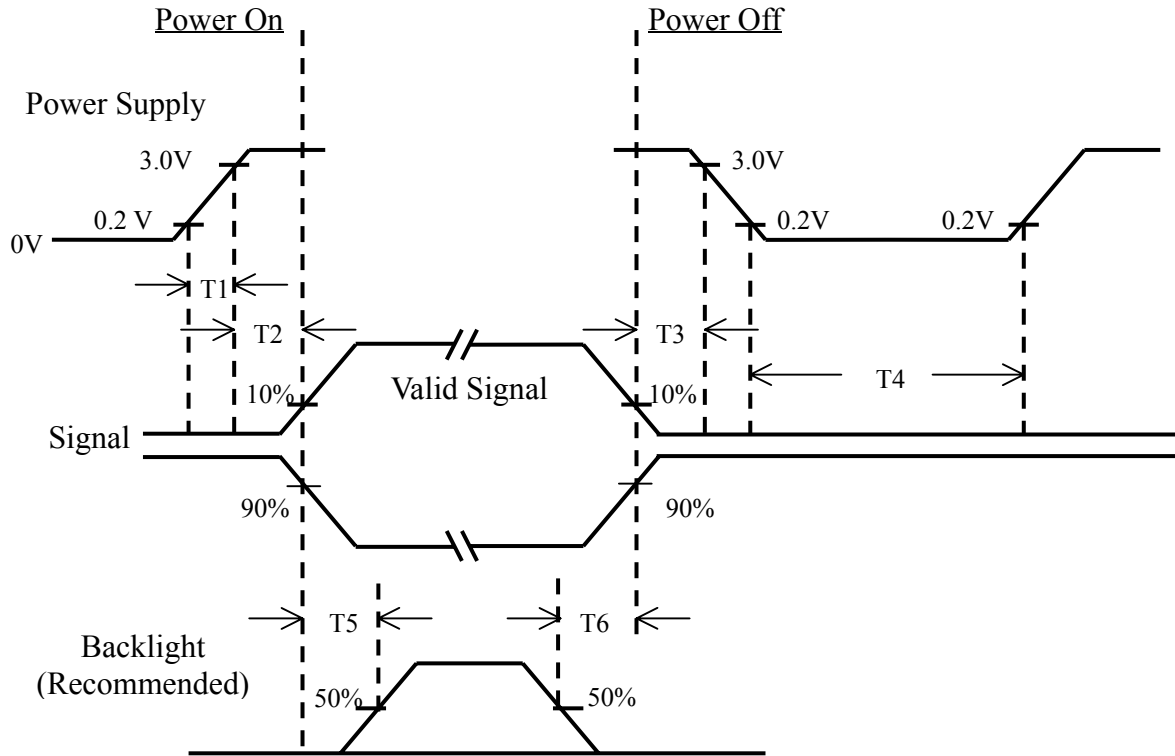

**Power ON/OFF Sequence**

Item	Min.	Typ.	Max.	Unit	Remark
T1	0	-	10	msec	
T2	0	-	50	msec	
T3	0	-	50	msec	
T4	400	-	-	msec	
T5	200	-	-	msec	
T6	200	-	-	msec	

Note (1) The supply voltage of the external system for the module input should be the same as the definition of  $V_{DD}$ .

- (2) Apply the lamp voltage within the LCD operation range. When the back-light turns on before the LCD operation or the LCD turns off before the back-light turns off, the display may momentarily become white.
- (3) In case of  $V_{DD} = \text{off level}$ , please keep the level of input signal on the low or keep a high impedance.
- (4) T4 should be measured after the module has been fully discharged between power off and on period.
- (5) Interface signal shall not be kept at high impedance when the power is on.

Document Title	HSD150PU15 Product Information	Page No.	26 / 31
Document No.		Revision	1.0

## 8.0 OUTLINE DIMENSION

### 8.1 Front View Outline Dimension

Unit : mm

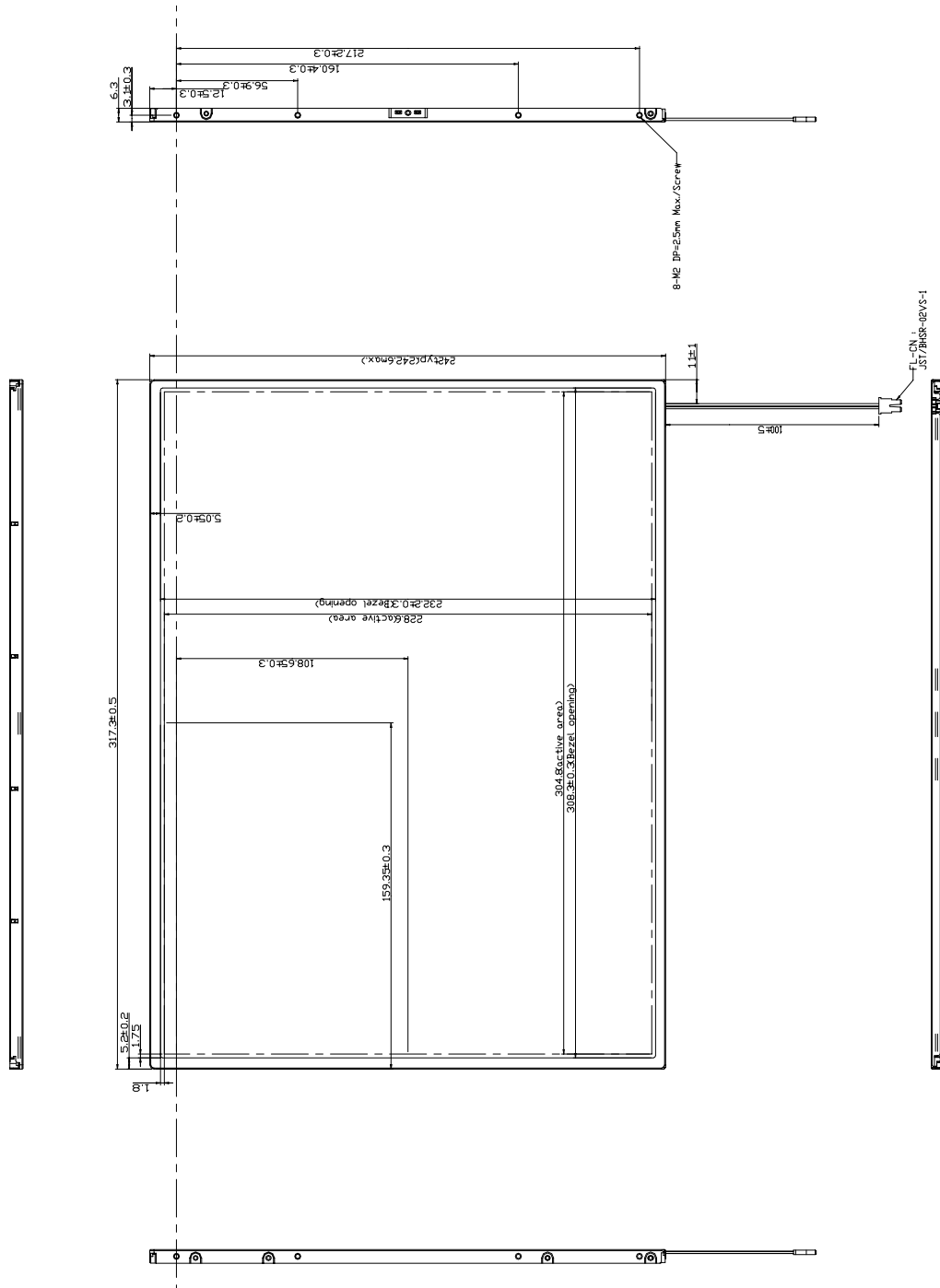

Document Title	HSD150PU15 Product Information	Page No.	27 / 31
Document No.		Revision	1.0

## 8.2 Back View Outline Dimension

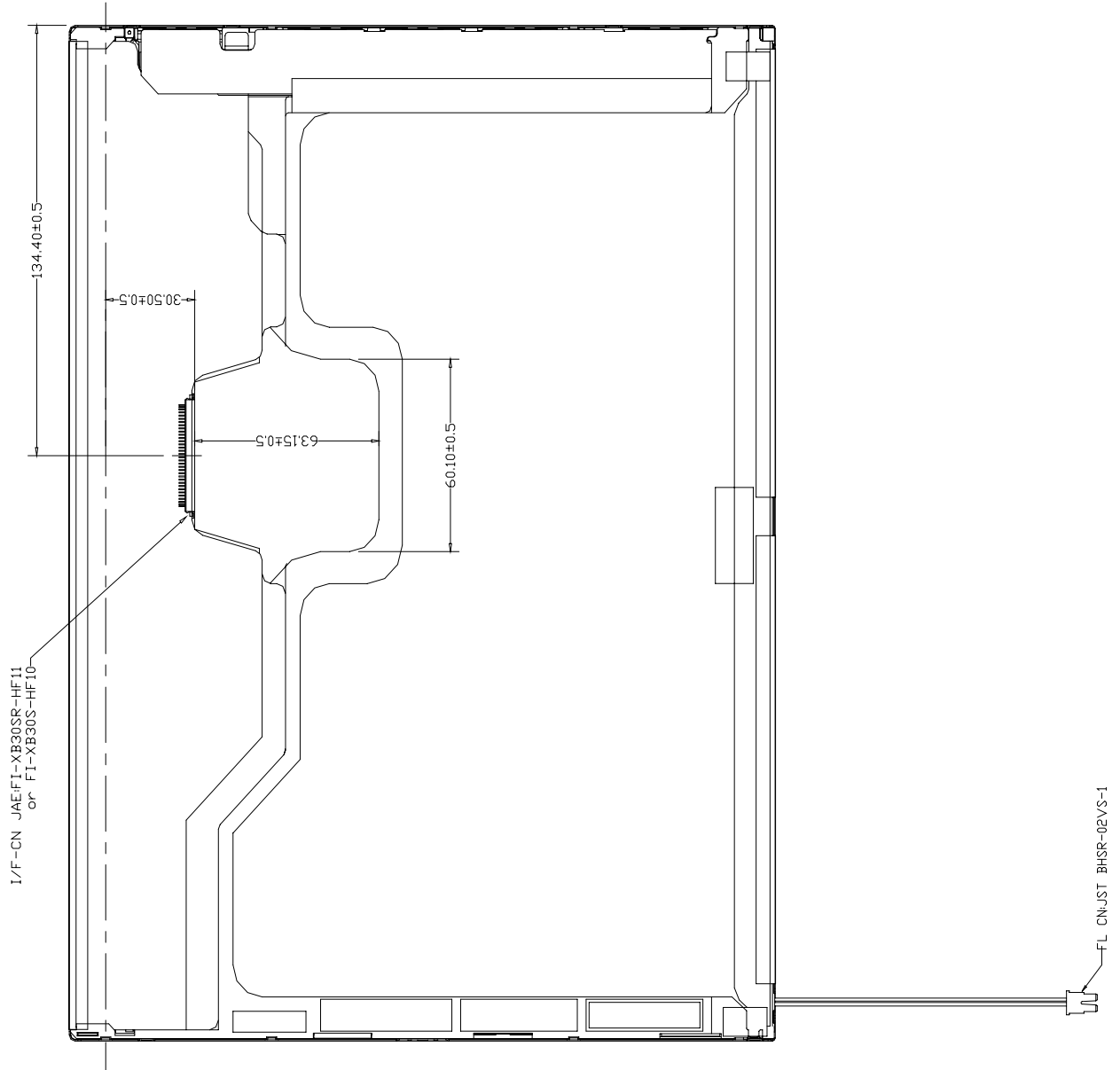

Document Title	HSD150PU15 Product Information	Page No.	28 / 31
Document No.		Revision	1.0

### 8.3 Tolerance of distance between active area and bezel opening

a - b      1.0 mm

c - d      1.0 mm

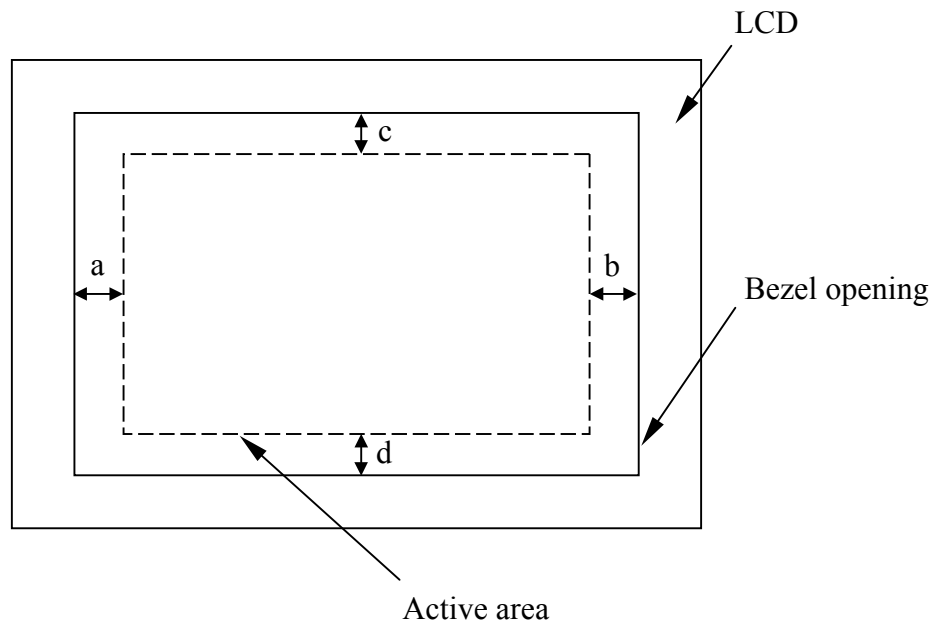

Document Title	HSD150PU15 Product Information	Page No.	29 / 31
Document No.		Revision	1.0

## 9.0 LOT MARK

### 9.1 Lot Mark

1	2	3	4	5	6	7	8	9	10	11	12	13	14	15
---	---	---	---	---	---	---	---	---	----	----	----	----	----	----

code 1,2,3,4,5,6: HannStar internal flow control code.

code 7: production location.

code 8: production year.

code 9: production month.

code 10,11,12,13,14,15: serial number.

#### Note (1) Production Year

Year	1999	2000	2001	2002	2003	2004	2005	2006	2007	2008
Mark	9	0	1	2	3	4	5	6	7	8

#### Note (2) Production Month

Month	Jan.	Feb.	Mar.	Apr.	May.	Jun.	Jul.	Aug.	Sep.	Oct	Nov.	Dec.
Mark	1	2	3	4	5	6	7	8	9	A	B	C

### 9.2 Location of Lot Mark

(1) The label is attached to the backside of the LCD module.

(2) This is subject to change without prior notice.

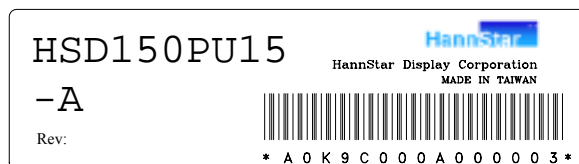

Lot mark

Document Title	HSD150PU15 Product Information	Page No.	30 / 31
Document No.		Revision	1.0

## 10.0 GENERAL PRECAUTION

### 10.1 Use Restriction

This product is not authorized for use in life supporting systems, aircraft navigation control systems, military systems and any other application where performance failure could be life-threatening or otherwise catastrophic.

### 10.2 Disassembling or Modification

Do not disassemble or modify the module. It may damage sensitive parts inside LCD module, and may cause scratches or dust on the display. HannStar does not warrant the module, if customers disassemble or modify the module.

### 10.3 Breakage of LCD Panel

10.3.1 If LCD panel is broken and liquid crystal spills out, do not ingest or inhale liquid crystal, and do not contact liquid crystal with skin.

10.3.2 If liquid crystal contacts mouth or eyes, rinse out with water immediately.

10.3.3 If liquid crystal contacts skin or cloths, wash it off immediately with alcohol and rinse thoroughly with water.

10.3.4 Handle carefully with chips of glass that may cause injury, when the glass is broken.

### 10.4 Electric Shock

10.4.1 Disconnect power supply before handling LCD module.

10.4.2 Do not pull or fold the CCFL cable.

10.4.3 Do not touch the parts inside LCD modules and the fluorescent lamp's connector or cables in order to prevent electric shock.

### 10.5 Absolute Maximum Ratings and Power Protection Circuit

10.5.1 Do not exceed the absolute maximum rating values, such as the supply voltage variation, input voltage variation, variation in parts' parameters, environmental temperature, etc., otherwise LCD module may be damaged.

10.5.2 Please do not leave LCD module in the environment of high humidity and high temperature for a long time.

10.5.3 It's recommended to employ protection circuit for power supply.

### 10.6 Operation

10.6.1 Do not touch, push or rub the polarizer with anything harder than HB pencil lead.

10.6.2 Use fingerstalls of soft gloves in order to keep clean display quality, when persons handle the LCD module for incoming inspection or assembly.

10.6.3 When the surface is dusty, please wipe gently with absorbent cotton or other soft material.



Document Title	HSD150PU15 Product Information	Page No.	31 / 31
Document No.		Revision	1.0

10.6.4 Wipe off saliva or water drops as soon as possible. If saliva or water drops contact with polarizer for a long time, they may causes deformation or color fading.

10.6.5 When cleaning the adhesives, please use absorbent cotton wetted with a little petroleum benzine or other adequate solvent.

**10.7 Mechanism**

Please mount LCD module by using mounting holes arranged in both sides tightly.

**10.8 Static Electricity**

10.8.1 Protection film must remove very slowly from the surface of LCD module to prevent from electrostatic occurrence.

10.8.2 Because LCD module use CMOS-IC on circuit board and TFT-LCD panel, it is very weak to electrostatic discharge. Please be careful with electrostatic discharge. Persons who handle the module should be grounded through adequate methods.

**10.9 Strong Light Exposure**

The module shall not be exposed under strong light such as direct sunlight. Otherwise, display characteristics may be changed.

**10.10 Disposal**

When disposing LCD module, obey the local environmental regulations.