

## **Engineering Specification**

**Type 12.1 XGA Color TFT/LCD Module  
Model Name: IAXG02C**

**Document Control Number : OEM I-902C-01**

**Note: Specification is subject to change without notice. Consequently it is better to contact to International Display Technology before proceeding with the design of your product incorporating this module.**

**Sales Support  
International Display Technology**

## **i Contents**

i	Contents
ii	Record of Revision
<b>1.0</b>	<b>Handling Precautions</b>
<b>2.0</b>	<b>General Description</b>
2.1	Characteristics
2.2	Functional Block Diagram
<b>3.0</b>	<b>Absolute Maximum Ratings</b>
<b>4.0</b>	<b>Optical Characteristics</b>
<b>5.0</b>	<b>Signal Interface</b>
5.1	Connectors
5.2	Interface Signal Connector
5.3	Interface Signal Description
5.4	Interface Signal Electrical Characteristics
5.4.1	Signal Electrical Characteristics for LVDS Receiver
5.4.2	LVDS Receiver Internal Circuit
5.4.3	Recommended Guidelines for Motherboard PCB Design and Cable Selection
5.5	Signal for Lamp connector
<b>6.0</b>	<b>Pixel format image</b>
<b>7.0</b>	<b>Parameter guide line for CFL Inverter</b>
<b>8.0</b>	<b>Interface Timings</b>
8.1	Timing Characteristics
8.2	Timing Definition
<b>9.0</b>	<b>Power Consumption</b>
<b>10.0</b>	<b>Power ON/OFF Sequence</b>
<b>11.0</b>	<b>Mechanical Characteristics</b>
<b>12.0</b>	<b>National Test Lab Requirement</b>

## ii Record of Revision

Date	Document Revision	Page	Summary
August 28,2002	OEM I-902C-01	All	First Edition for customer. Basec on Internal Spec. as of July 4,2002. (Cable Length : 60mm +/-5)

## 1.0 Handling Precautions

- If any signals or power lines deviate from the power on/off sequence, it may cause shorten the life of the LCD module.
- The LCD panel and the CFL are made of glass and may break or crack if dropped on a hard surface, so please handle them with care.
- CMOS ICs are included in the LCD panel. They should be handled with care, to prevent electrostatic discharge.
- Do not press the reflector sheet at the LCD module to any directions.
- Do not stick the adhesive tape on the reflector sheet at the back of the LCD module.
- Please handle with care when mount in the system cover. Mechanical damage for lamp cable/lamp connector may cause safety problems.
- Small amount of materials having no flammability grade is used in the LCD module. The LCD module should be supplied by power complied with requirements of Limited Power Source (2.5, IEC60950 or UL60950), or be applied exemption conditions of flammability requirements (4.7.3.4, IEC60950 or UL60950) in an end product.
- The LCD module is designed so that the CFL in it is supplied by Limited Current Circuit (2.4, IEC60950 or UL60950).
- The fluorescent lamp in the liquid crystal display(LCD) contains mercury. Do not put it in trash that is disposed of in landfills. Dispose of it as required by local ordinances or regulations.
- Never apply detergent or other liquid directly to the screen.
- Wipe off water drop immediately. Long contact with water may cause discoloration or spots.
- When the panel surface is soiled, wipe it with absorbent cotton or other soft cloth; do not use solvents or abrasives.
- Do not touch the front screen surface in your system, even bezel.
- Gently wipe the covers and the screen with a soft cloth.

- |  |
|--|
| <ul style="list-style-type: none"><li>• The information contained herein is presented only as a guide for the applications of our products. No responsibility is assumed by International Display Technology for any infringements of patents or other right of the third parties which may result from its use. No license is granted by implication or otherwise under any patent or patent rights of International Display Technology or others.</li><li>• The information contained herein may be changed without prior notice. It is therefore advisable to contact International Display Technology before proceeding with the design of equipment incorporating this product.</li></ul> |
|--|

## 2.0 General Description

This specification applies to the Type 12.1 Color TFT/LCD Module 'IAXG02C'.  
 This module is designed for a display unit of a notebook style personal computer.  
 The screen format and electrical interface are intended to support the XGA (1024(H) x 768(V)) screen.  
 Support color is native 262k colors ( RGB 6-bit data driver ).  
 All input signals are LVDS(Low Voltage Differential Signaling) interface compatible.  
 This module does not contain an inverter card for backlight.

## 2.1 Characteristics

The following items are characteristics summary on the table under 25 degree C condition:

CHARACTERISTICS ITEMS	SPECIFICATIONS
Screen Diagonal [cm]	307.2
Active Area [mm]	245.76(H) x 184.32(V)
Pixels H x V [pixels]	1024(x3) x 768
Pixel Pitch [mm]	0.240(per one triad) x 0.240
Pixel Arrangement	R.G.B. Vertical Stripe
Display Mode	Normally White
White Luminance [cd/m <sup>2</sup> ]	150 Typ. (Screen Center, ICFL = 6.0mA)
Contrast Ratio	250 : 1 Typ.
Optical Rise Time+Fall Time [msec]	50 Max.
Nominal Input Voltage [Volt]	+3.3 Typ. (VDD)
Logic Power Consumption [watt]	0.9( <b>TBD</b> ) Typ. (VDD)(All Black Pattern)
Backlight Power Consumption [watt]	3.4 Typ.(@CFL current 6.0mA )
Weight [grams]	260 Typ.,270 Max.
Physical Size [mm]	261.0(W) x 198.0(H) x 4.7(D) Typ. (without Inverter)
Electrical Interface	4 pairs LVDS(R/G/B Data (6-bit), 3 sync signals, Clock), EEDID(clock, data)
Support Color	Native 262K colors ( RGB 6-bit data driver )
Temperature Range [deg. C]	0 to +50 (Operating) -20 to +60 (Storage, Shipping)

## 2.2 Functional Block Diagram

The following diagram shows the functional block of the Type 12.1 Color TFT/LCD Module.

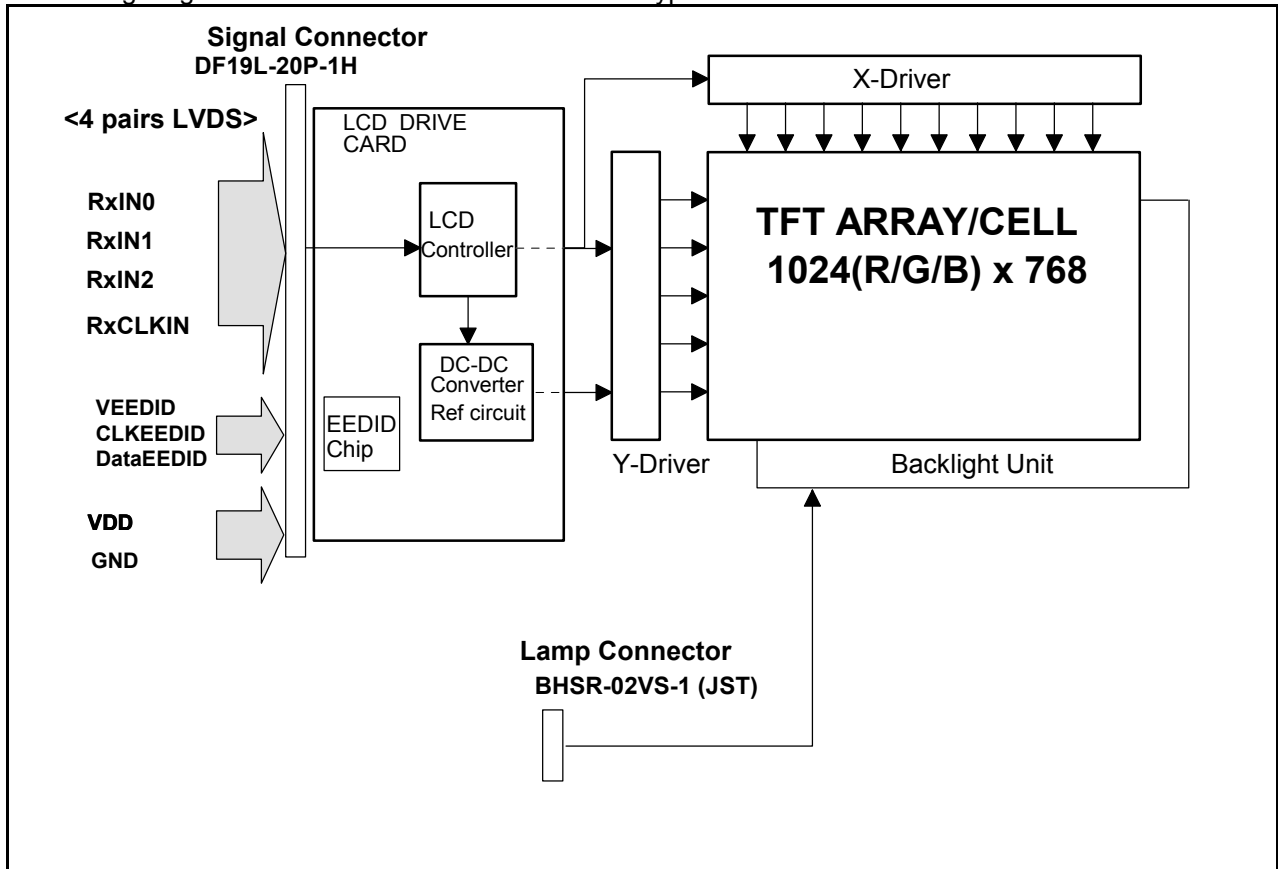

### 3.0 Absolute Maximum Ratings

Absolute maximum ratings of the module is as follows :

Item	Symbol	Min	Max	Unit	Conditions
Supply Voltage	VDD	-0.3	+4.0	V	
Input Voltage of Signal	Other Inputs	-0.3	VDD+0.3	V	
Lamp Ignition Voltage	Vinv	-	+1,500	Vrms	Ta = 0 [deg.C]
CFL Current	ICFL	-	7	mArms	
CFL Peak Inrush Current	ICFLP	-	20	mArms	Ta = 25 [deg.C] <b>(Note 1)</b>
Operating Temperature	TOP	0	+50	deg.C	<b>(Note 2)</b>
Operating Relative Humidity	HOP	8	95	%RH	<b>(Note 2)</b>
Storage Temperature	TST	-20	+60	deg.C	<b>(Note 2)</b>
Storage Relative Humidity	HST	5	95	%RH	<b>(Note 2)</b>
Vibration			1.5 10-200	G Hz	
Shock			50 18 220 2	G ms G ms	Rectangle wave Half Sine Wave

**Note :**

1. Duration : 50 [msec] Max.
2. Maximum Wet-Bulb should be 39 degree C and No condensation.

## 4.0 Optical Characteristics

The optical characteristics are measured under stable conditions as follows under 25 degree C condition:

Item	Conditions	Specification	
		Typ.	Note
Viewing Angle (Degrees)	Horizontal (Right)	40	-
	$K \geq 10$ (Left)	40	-
K: Contrast Ratio	Vertical (Upper)	15	-
	$K \geq 10$ (Lower)	30	-
Contrast ratio		250	-
Response Time (ms)	Rising + Falling	-	50 Max.
Color Chromaticity (CIE)	Red x	0.577	-
	Red y	0.338	-
	Green x	0.310	-
	Green y	0.544	-
	Blue x	0.158	-
	Blue y	0.124	-
	White x	0.313	-
	White y	0.329	-
White Luminance (cd/m <sup>2</sup> ) ICFL 6.0 mA		150Typ. Center	120 Min. Center
		140Typ. 5 points average	112 Min. 5 points average

## 5.0 Signal Interface

### 5.1 Connectors

Physical interface is described as for the connector on module.

These connectors are capable of accommodating the following signals and will be following components.

Connector Name / Designation	For Signal Connector
Manufacturer	HIROSE
Type / Part Number	DF19L-20P-1H
Mating Receptacle/Part Number	DF19G-20S-1F (FPC Type) DF19G-20S-1C (Cable Type)

Connector Name / Designation	For Lamp Connector
Manufacturer	JST
Type / Part Number	BHSR-02VS-1
Mating Type / Part Number	SM02B-BHSS-1

## 5.2 Interface Signal Connector

Pin #	Signal Name
1	GND
2	VDD
3	VDD
4	VEDID (Note 2, 3)
5	Reserved (Note 1)
6	CLKEDID (Note 2, 4)
7	DataEDID (Note 2, 4)
8	RxIN0- (Note 5)
9	RxIN0+(Note 5)
10	GND

Pin #	Signal Name
11	RxIN1-(Note 5)
12	RxIN1+(Note 5)
13	GND
14	RxIN2-(Note 5)
15	RxIN2+(Note 5)
16	GND
17	RxCLKIN-(Note 5)
18	RxCLKIN+(Note 5)
19	GND
20	GND

### Note :

- 'Reserved' pins are not allowed to connect any other line.
- This LCD Module complies with "VESA ENHANCED EXTENDED DISPLAY IDENTIFICATION DATA STANDARD Release A, Revision 1" and supports "EEDID version 1.3". This module is equipped with a I<sup>2</sup>C compatible EEPROM FM24C03U (Fairchild Semiconductor International), whose device address is fixed zero.
- V<sub>EEDID</sub> power source shall be the limited current circuit which has not exceeding 1A. (Reference Document : "Enhanced Display Data Channel (E-DDC™) Proposed Standard", VESA)
- Both CLK<sub>EEDID</sub> line and DATA<sub>EEDID</sub> line are pulled up with 10k ohm resistor to V<sub>EEDID</sub> power source line at LCD panel, respectively.
- Voltage levels of all input signals are LVDS compatible. Refer to "Signal Electrical Characteristics for LVDS", for voltage levels of all input signals.

## 5.3 Interface Signal Description

### Signal Description

Signal Name	Description
RxIN0+, RxIN0-	LVDS differential data input (Red0-Red5, Green0)
RxIN1+, RxIN1-	LVDS differential data input (Green1-Green5, Blue0-Blue1)
RxIN2+, RxIN2-	LVDS differential data input (Blue2-Blue5, HSync, VSync, DSPTMG)
RxCLKIN+, RxCLKIN-	LVDS differential clock input
VDD	+3.3V Power Supply
GND	Ground

### Note :

- The module uses a 100ohm resistor between positive and negative data lines of each receiver input.
- Input signals shall be low or Hi-Z state when VDD is off.

SIGNAL NAME	Description	
+RED5 +RED4 +RED3 +RED2 +RED1 +RED0	Red Data 5 (MSB) Red Data 4 Red Data 3 Red Data 2 Red Data 1 Red Data 0 (LSB)	Red-pixel Data Each red pixel's brightness data consists of these 6 bits pixel data.
+GREEN 5 +GREEN 4 +GREEN 3 +GREEN 2 +GREEN 1 +GREEN 0	Green Data 5 (MSB) Green Data 4 Green Data 3 Green Data 2 Green Data 1 Green Data 0 (LSB)	Green-pixel Data Each green pixel's brightness data consists of these 6 bits pixel data.
+BLUE 5 +BLUE 4 +BLUE 3 +BLUE 2 +BLUE 1 +BLUE 0	Blue Data 5 (MSB) Blue Data 4 Blue Data 3 Blue Data 2 Blue Data 1 Blue Data 0 (LSB)	Blue-pixel Data Each blue pixel's brightness data consists of these 6 bits pixel data.
-DTCLK	Data Clock	The typical frequency is 65.0 MHz. The signal is used to strobe the pixel data and DSPTMG signals. All pixel data shall be valid at the falling edge when the DSPTMG signal is high.
DSPTMG	Display Timing	This signal is strobed at the falling edge of -DTCLK. When the signal is high, the pixel data shall be valid to be displayed.
VSYNC	Vertical Sync	The signal is synchronized to -DTCLK .
HSYNC	Horizontal Sync	The signal is synchronized to -DTCLK .

**Note :** Output signals from any system shall be low or Hi-Z state when VDD is off.

## 5.4 Interface Signal Electrical Characteristics

### 5.4.1 Signal Electrical Characteristics for LVDS Receiver

The LVDS receiver equipped in this LCD module is compatible with ANSI/TIA/TIA-644 standard.

#### Electrical Characteristics

Parameter	Symbol	Min	Typ	Max	Unit	Conditions
Differential Input High Threshold	Vth			+100	mV	Vcm=+1.2V
Differential Input Low Threshold	Vtl	-100			mV	Vcm=+1.2V
Magnitude Differential Input Voltage	Vid	100		600	mV	
Common Mode Voltage	Vcm	1.0	1.2	1.4	V	Vth - Vtl = 200mV
Common Mode Voltage Offset	$\Delta V_{cm}$	-50		+50	mV	Vth - Vtl = 200mV

#### Note :

- Input signals shall be low or Hi-Z state when VDD is off.
- All electrical characteristics for LVDS signal are defined and shall be measured at the interface connector of LCD (See Figure "Measurement system").

#### Voltage Definitions

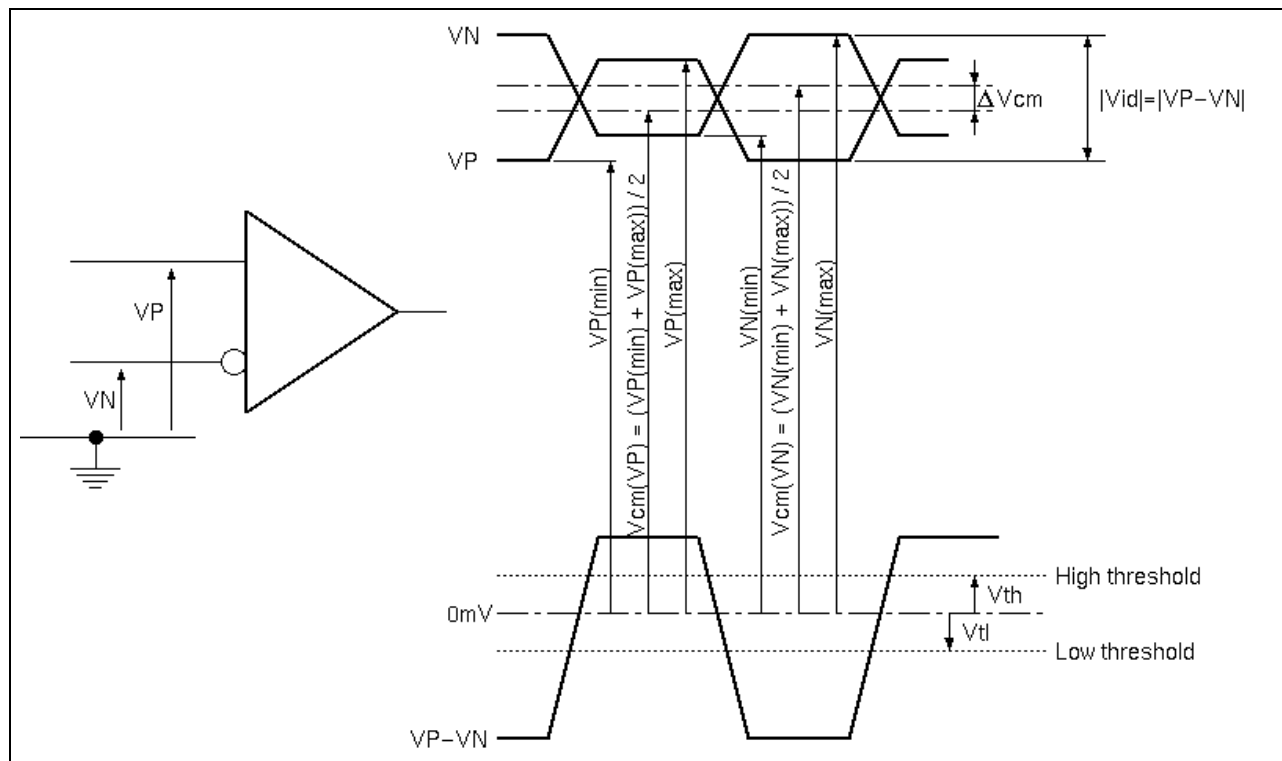

Measurement System

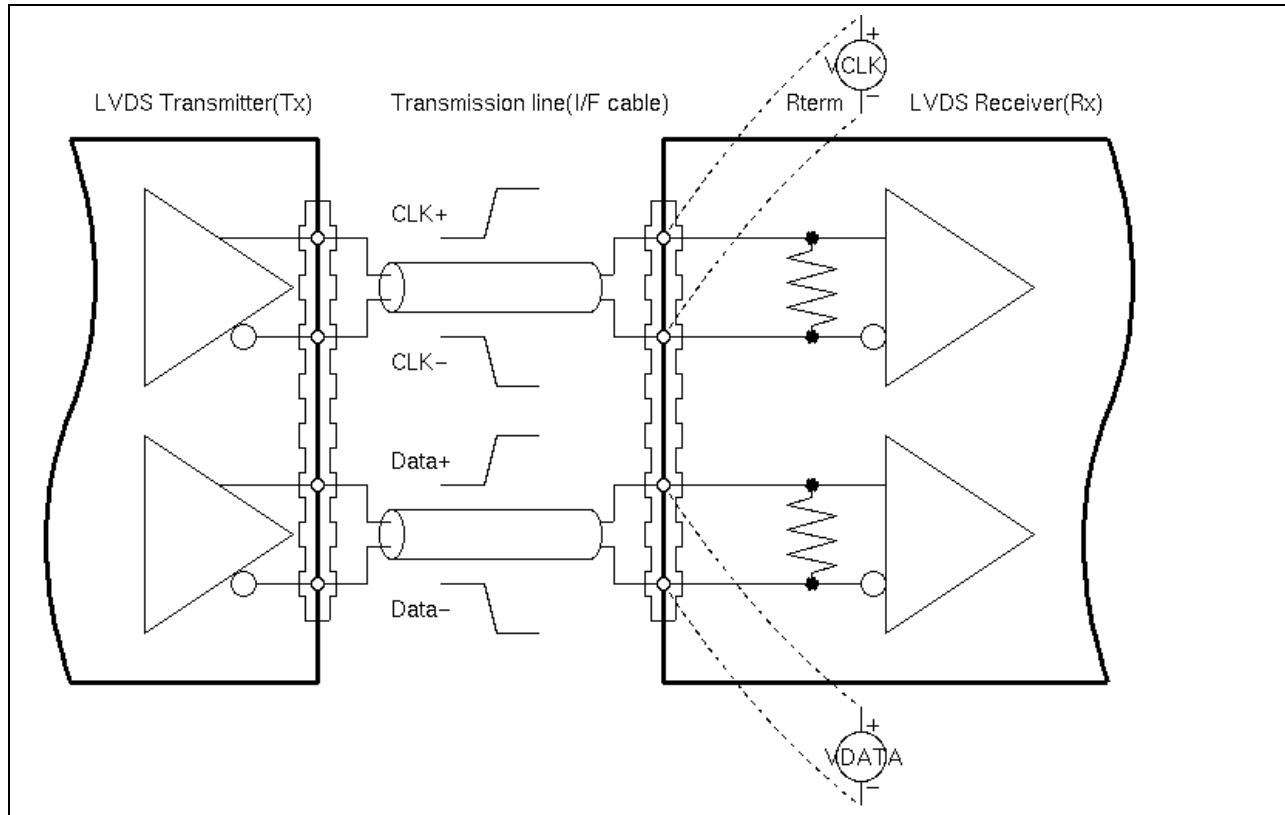

Timing Requirements

Parameter	Symbol	Min	Typ	Max	Unit	Conditions
Clock Frequency	fc	50	65	67	MHz	
Cycle Time	tc	14.93	15.38	20.00	ns	
Data Setup Time (Note 1)	Tsu	600			ps	fc = 65MHz, tCCJ < 50ps, Vth-Vtl = 200mV, Vcm = 1.2V, ΔVcm = 0
Data Hold Time (Note 2)	Thd	600			ps	
Cycle-to-cycle jitter (Note 3)	tCCJ	-150		+150	ps	fc = 65MHz, Tsu=Thd=900ps
Cycle Modulation Rate (Note 4)	tCJavg			20	ps/clock	fc = 65MHz, Tsu=Thd=900ps

**Note :**

1. All values are at VDD=3.3V, Ta=25 degree C.
2. See figure "**Timing Definition**" and "**Timing Definition(detail A)**" for definition.
3. Jitter is the magnitude of the change in input clock period.
4. This specification defines maximum average cycle modulation rate in peak-to-peak transition within any 100 clock cycles. Figure "**Cycle Modulation Rate**" illustrates a case against this requirement. This specification is applied only if input clock peak jitter within any 100 clock cycles is greater than 300ps.

Timing Definition

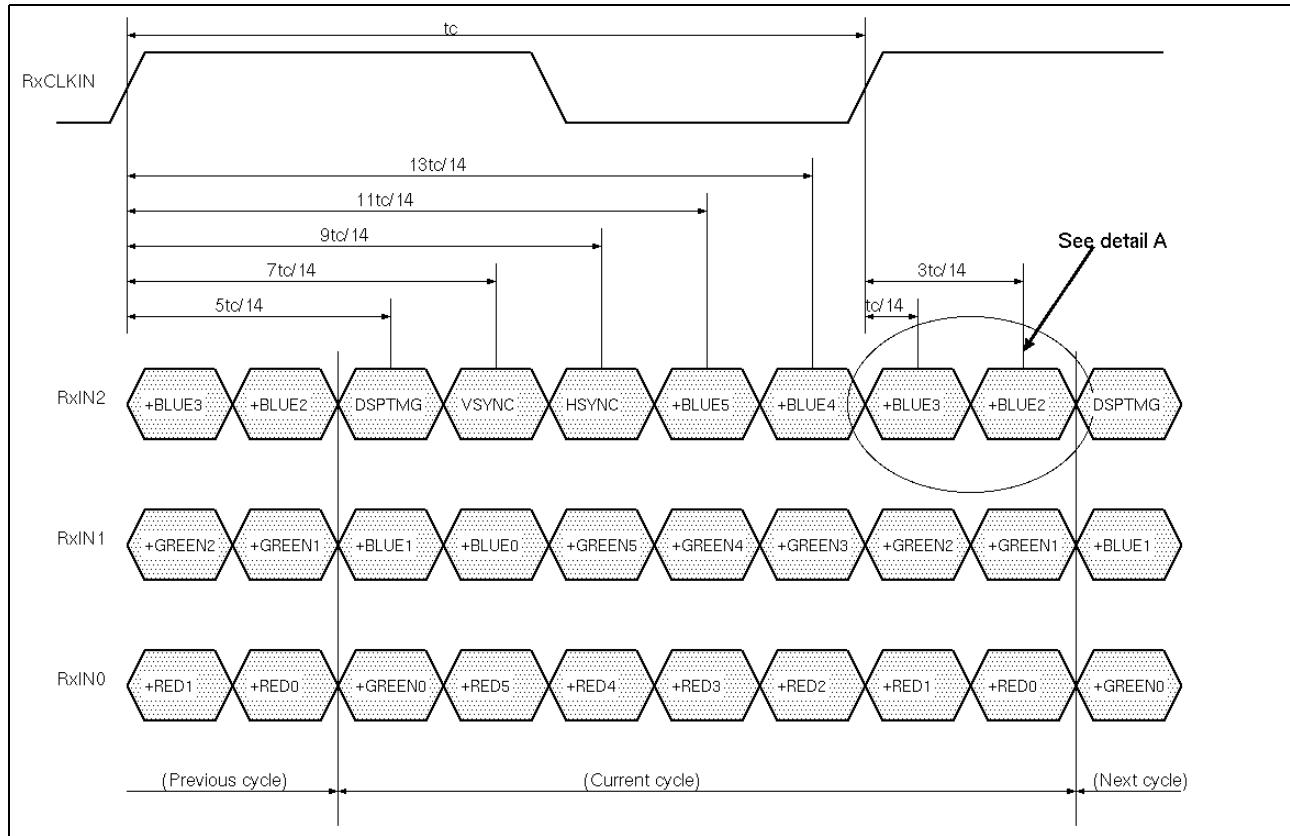

Timing Definition(detail A)

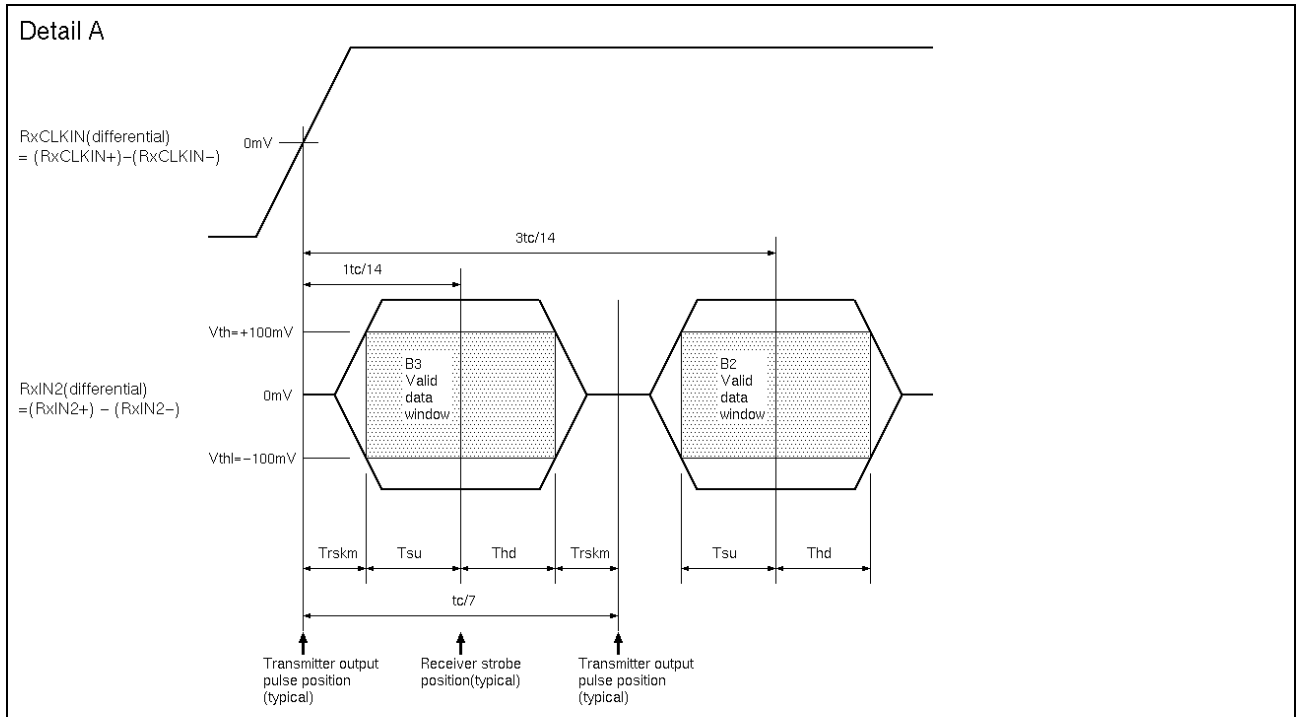

**Note:**  $Tsu$  and  $Thd$  are internal data sampling window of receiver.  $Trskm$  is the system skew margin; i.e., the sum of cable skew, source clock jitter, and other inter-symbol interference, shall be less than  $Trskm$ .

Cycle Modulation Rate

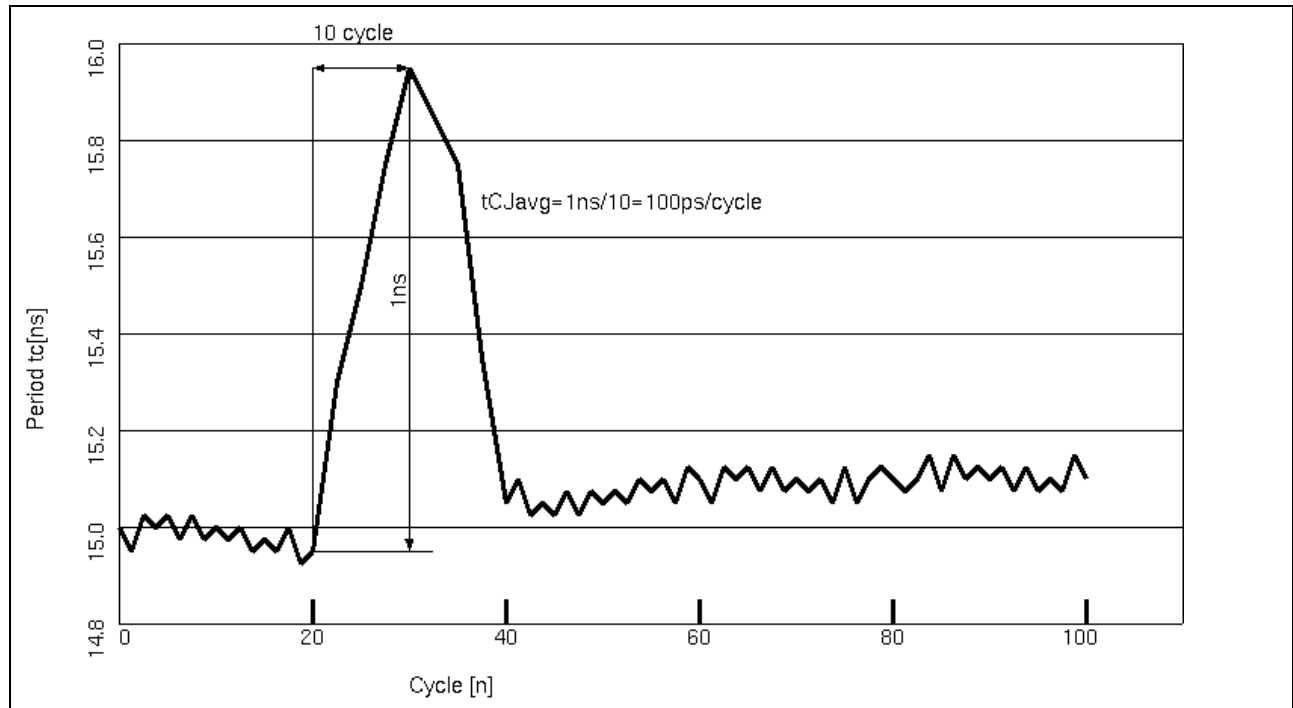

### 5.4.2 LVDS Receiver Internal Circuit

The following figure shows the internal block diagram of the LVDS receiver. This LCD module equips termination resistors for LVDS link.

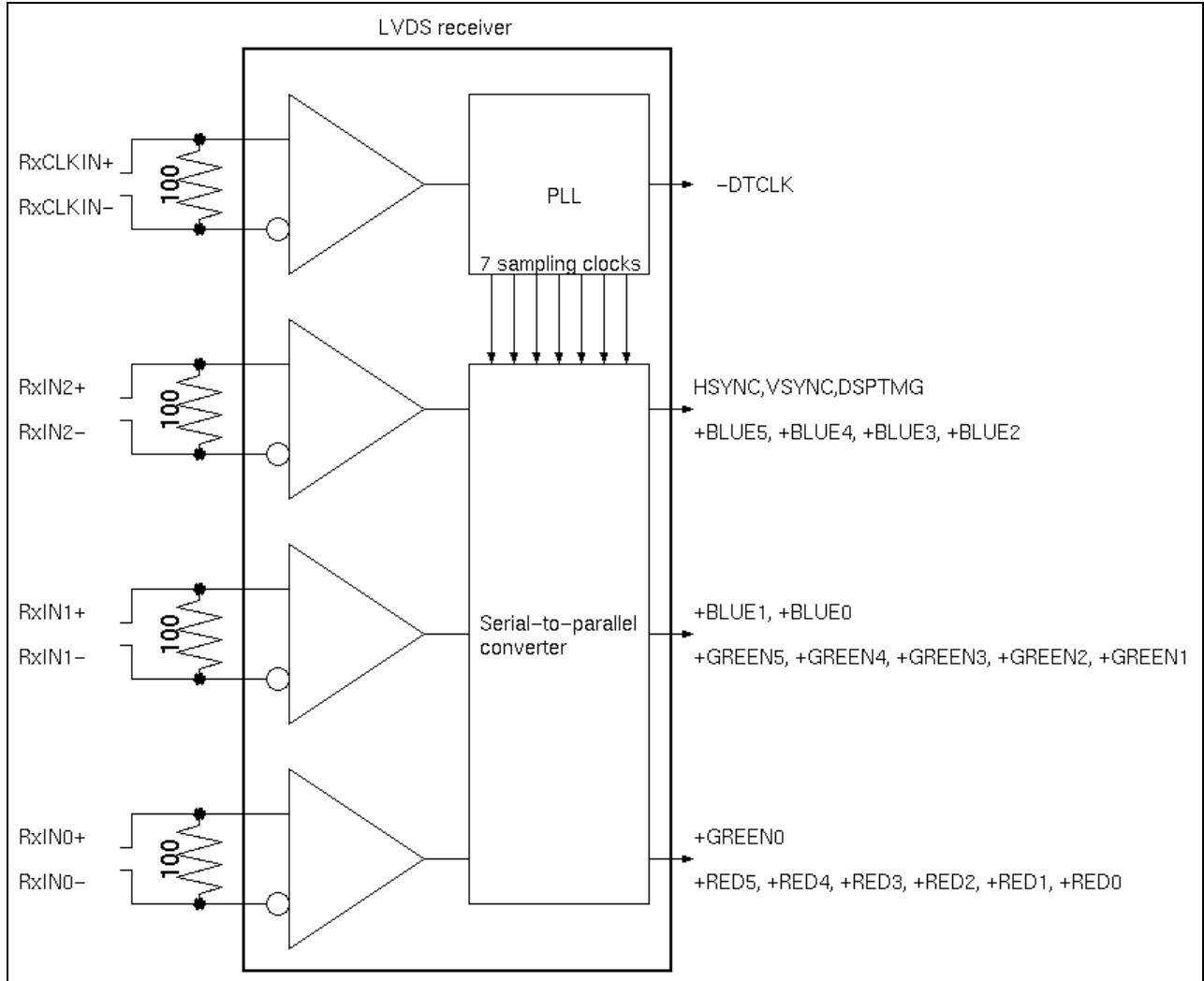

### 5.4.3 Recommended Guidelines for Motherboard PCB Design and Cable Selection

- Following the suggestions below will help to achieve optimal results.
- Use controlled impedance media for LVDS signals. They should have a matched differential impedance of 100 ohm.
- Match electrical lengths between traces to minimize signal skew.
- Isolate TEL signals from LVDS signals.
- For cables, twisted pair, twin, or flex circuit with close coupled differential traces are recommended.

## 5.5 Signal for Lamp Connector

Pin #	Signal Name
1	Lamp High Voltage
2	Lamp Low Voltage

## 6.0 Pixel format image

Following figure shows the relationship of the input signals and LCD pixel format image. Even and odd pair of RGB data are sampled at a time.

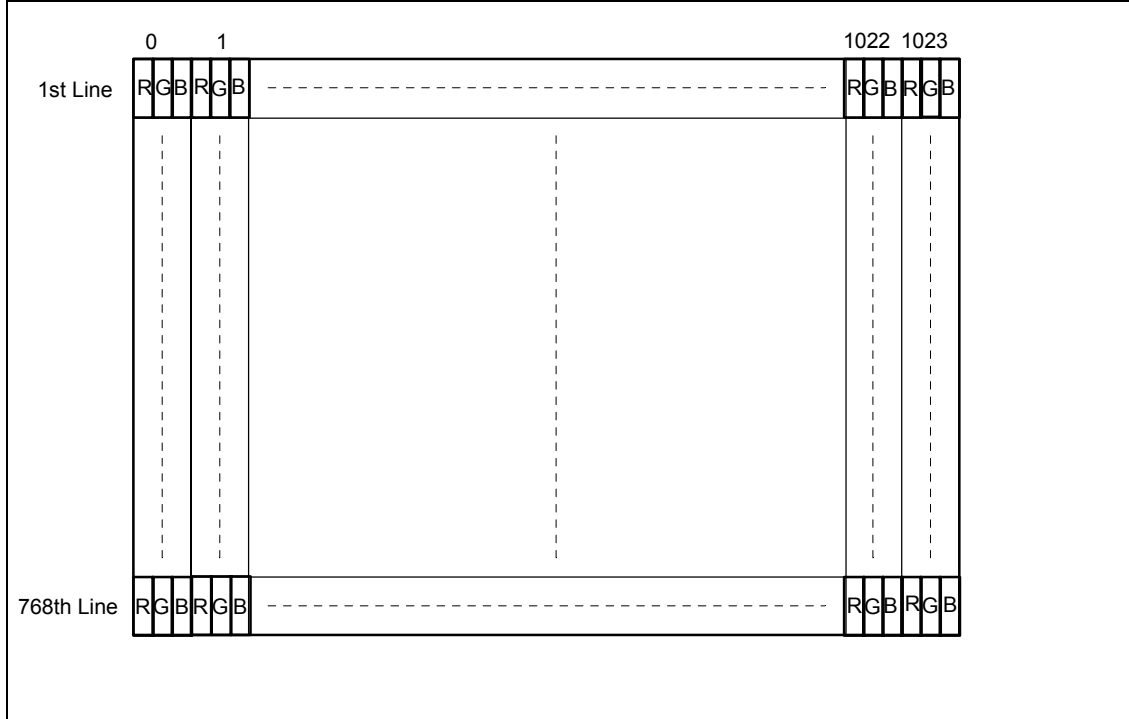

## 7.0 Parameter guide line for CFL Inverter

SYMBOL	PARAMETER	MIN	D.P (Note 1)	MAX	UNITS	CONDITION
(L63)	White Luminance (Center) (5 points average)	- -	150 140	- -	[cd/m <sup>2</sup> ] [cd/m <sup>2</sup> ]	Ta=25[deg. C]
ICFL	CFL current	3.0	6.0	7.0	[mA <sub>rms</sub> ]	Ta=25[deg. C] <b>(Note 2)</b>
ICFLP	CFL Peak Inrush Current			20	[mA]	Ta=25[deg. C] <b>(Note 2,6)</b>
FCFL	CFL Frequency	40		60	[kHz]	Ta=25[deg. C] <b>(Note 3)</b>
VCFLi	Inverter Ignition Voltage	1,600			[V <sub>rms</sub> ]	Ta=0[deg. C]
VCFL	CFL Voltage (Reference)		560		[V <sub>rms</sub> ]	Ta=25[deg. C]
PCFL	CFL Power consumption		3.4		[W]	Ta=25[deg. C] <b>(Note 4)</b>

**Note :**

1. Design Point
2. If it exceeds MIN/MAX values, then "CFL Life" , "ON/OFF Cycle", and "SAFETY" will not be guaranteed.
3. CFL Frequency should be carefully determined to avoid interference between inverter and TFT LCD.
4. Calculated value for reference (ICFL x VCFL = PCFL).
5. It should be employed the inverter which has `Duty Dimming`, if ICFL is less than 4[mA].
6. Duration: 50msec MAX

The following chart is Luminance versus Lamp Current for your reference.

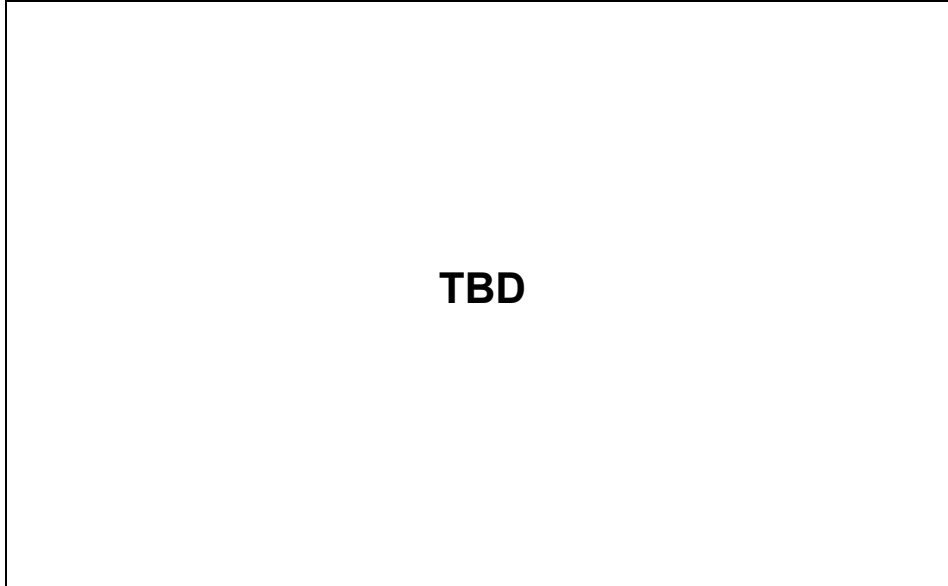

## 8.0 Interface Timings

Basically, interface timings should match the VESA 1024x768 / 60 Hz (VG901101) manufacturing guide line timing. These timings described here are not actual input timings of LCD module but output timings of SN75LVDS86DGG(Texas Instruments) or equivalent.

### 8.1 Timing Characteristics

Symbol		MIN	TYP	MAX	Unit	Note
fdck	DTCLK Frequency		65.00		MHz	
tck	DTCLK cycle time		15.38		nsec	
tx	X total time	1206	1344	2047	tck	
tacx	X active time	1024	1024	1024	tck	
Hsync	H frequency		48.363		KHz	
Hsw	H-Sync width	8	136		tck	2
Hbp	H back porch	8	160		tck	2
Hfp	H front porch	0	24		tck	
ty	Y total time	777	806	1023	tx	
tacy	Y active time	768	768	768	tx	
Vsync	Frame rate	(55)	60	61	Hz	
Vw	V-sync Width	1	6		tx	
Vfp	V-sync front porch	1	3		tx	
Vbp	V-sync back porch	7	29	63	tx	3

**Note1** :  $tbkx = Hfp + Hsw + Hbp$

**Note2** :  $32 \leq Hsw + Hbp < 515$  [tck].

**Note3** : Vbp should be static.

If timing signal is invalid, the LCD enters "self protection mode" and the screen becomes whole black. Once the signal is back, it resumes normal operation.

## 8.2 Timing Definition

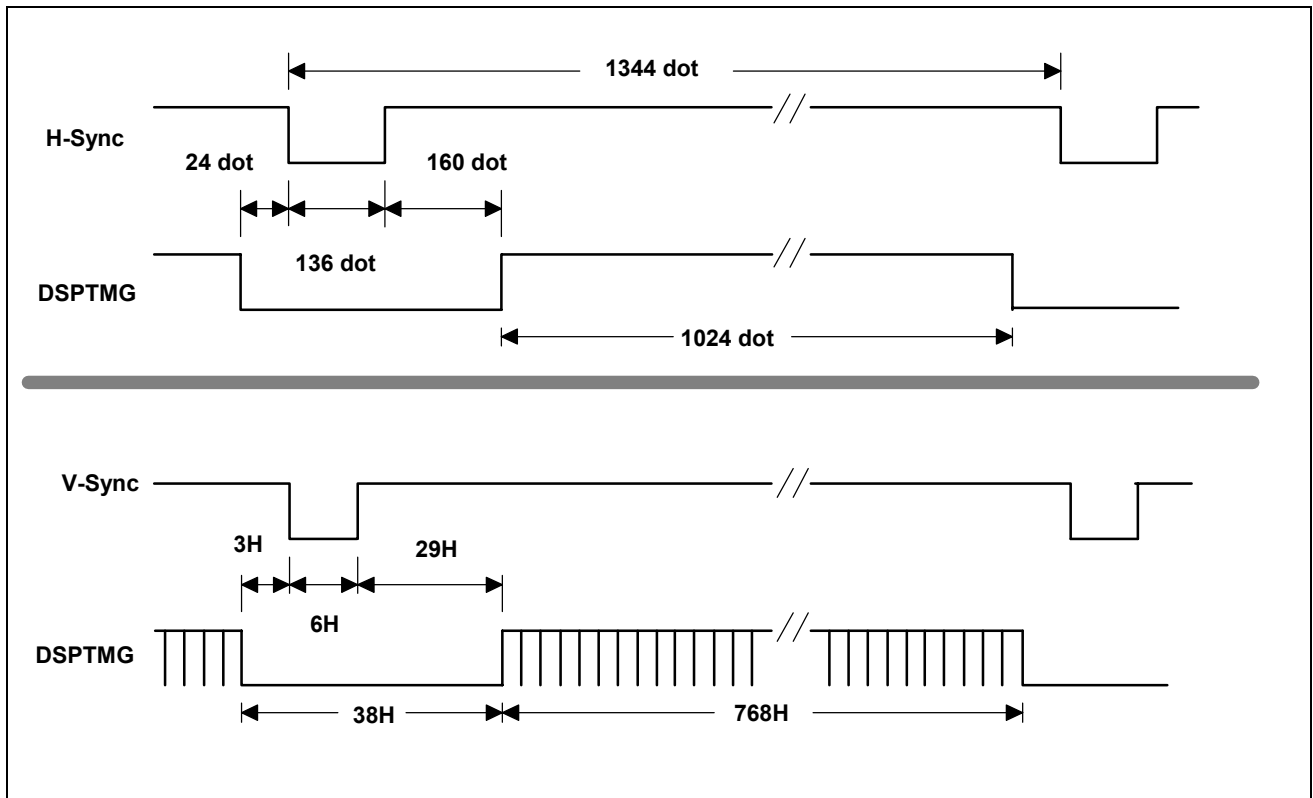

## 9.0 Power Consumption

Input power specifications are as follows;

SYMBOL	PARAMETER	Min	Typ	Max	UNITS	CONDITION
VDD	Logic/LCD Drive Voltage	3.0	3.3	3.6	[V]	Load Capacitance 20[uF]
PDD	VDD Power			1.2	[W]	Max. Pattern, VDD=3.6[V] <b>(TBD)</b>
PDD	VDD Power		0.9		[W]	All Black Pattern, VDD=3.3[V] <b>(TBD)</b>
IDD	VDD Current			340	[mA]	Max Pattern, VDD=3.6[V] <b>(TBD)</b>
IDD	VDD Current		250		[mA]	All Black Pattern, VDD=3.3[V] <b>(TBD)</b>
VDDrp	Allowable Logic/LCD Drive Ripple Voltage			100	[mVp-p]	

## 10.0 Power ON/OFF Sequence

VDD power and lamp on/off sequence is as follows. Interface signals are also shown in the chart. Signals from any system shall be Hi-Z state or low level when VDD is off.

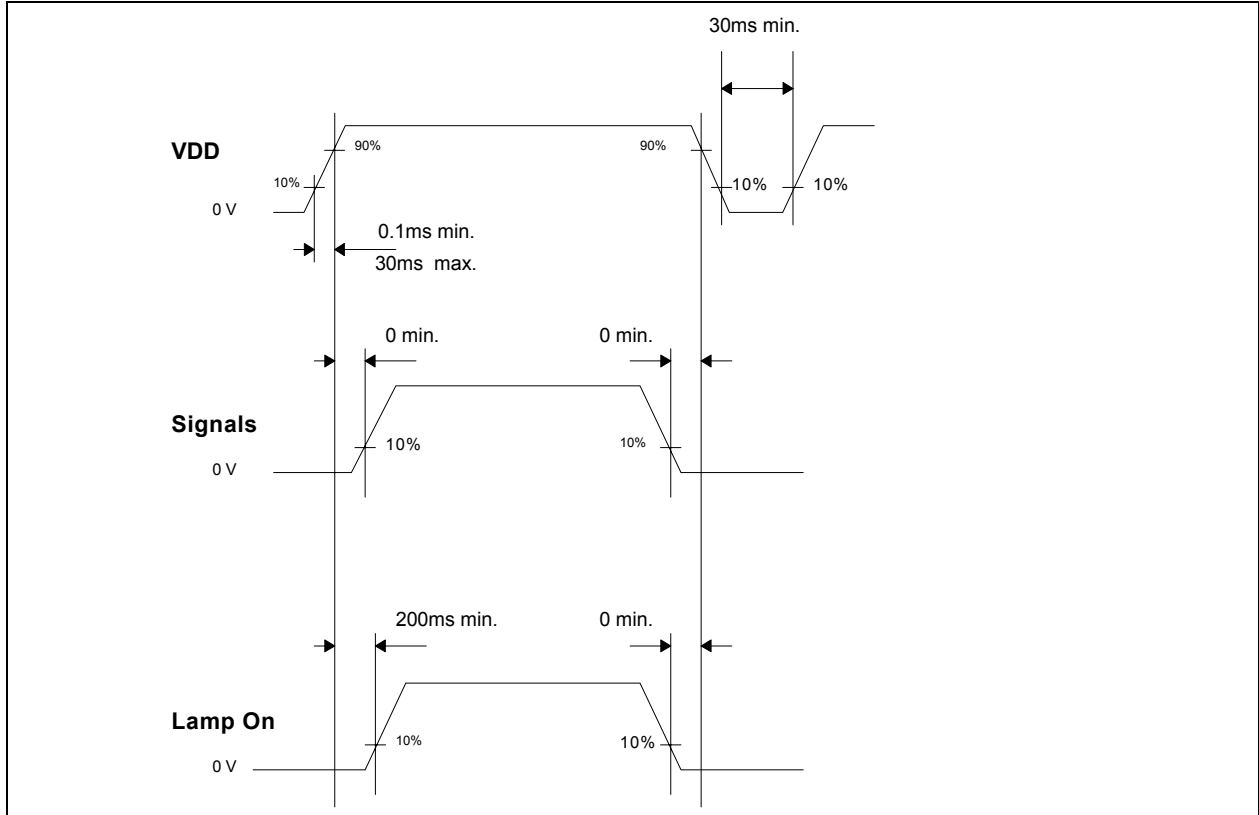



## 12.0 National Test Lab Requirement

The display module satisfied all requirements for compliance to  
UL 60950, 3rd Edition      U.S.A. Information Technology Equipment

\*\*\*\*\* End Of Page \*\*\*\*\*